

harman/kardon

# DPR1001

DIGITAL PATH AUDIO/VIDEO RECEIVER

## SERVICE MANUAL



### CONTENTS

ELECTROSTATICALLY SENSITIVE DEVICES.....	2	EXPLODED VIEW PARTS LIST.....	23
LEAKAGE TESTING.....	3	BLOCK DIAGRAM.....	24
SPECIFICATIONS.....	4	TECHNOLOGY OVERVIEW.....	25
DETAILED SPECIFICATIONS.....	5	POWER SUPPLY (SMPS).....	39
FRONT PANEL CONTROLS.....	14	TUNER SCHEMATICS/SPECS.....	47
FRONT PANEL CONNECTIONS.....	15	PCB DRAWINGS.....	52
REAR PANEL CONTROLS.....	16	MECHANICAL PARTS LIST.....	72
REAR PANEL CONNECTIONS.....	17	ELECTRICAL PARTS LIST.....	74
MAIN REMOTE CONTROL FUNCTIONS.....	18	SEMICONDUCTOR DATA.....	107
TROUBLESHOOTING GUIDE.....	21	SCHEMATICS.....	143
PROCESSOR RESET.....	21	WIRING DIAGRAM.....	164
UNIT EXPLODED VIEW.....	22	PACKAGING.....	165

harman/kardon, Inc.  
250 Crossways Park Dr.  
Woodbury, New York 11797

Rev2 2/2009

# ELECTROSTATICALLY SENSITIVE (ES) DEVICES

Some semiconductor (solid state) devices can be damaged easily by static electricity. Such components commonly are called Electrostatically Sensitive (ES) Devices. Examples of typical ES devices are integrated circuits and some field effect transistors and semiconductor "chip" components.

The following techniques should be used to help reduce the incidence of component damage caused by static electricity.



1. Immediately before handling any semiconductor component or semiconductor-equipped assembly, drain off any electrostatic charge on your body by touching a known earth ground. Alternatively, obtain and wear a commercially available discharging wrist strap device, which should be removed for potential shock reasons prior to applying power to the unit under test.
2. After removing an electrical assembly equipped with ES devices, place the assembly on a conductive surface such as aluminum foil, to prevent electrostatic charge build-up or exposure of the assembly.
3. Use only a grounded-tip soldering iron to solder or unsolder ES devices.
4. Use only an anti-static solder removal device. Some solder removal devices not classified as "anti-static" can generate electrical charges sufficient to damage ES devices.
5. Do not use freon-propelled chemicals. These can generate electrical charge sufficient to damage ES devices.
6. Do not remove a replacement ES device from its protective package until immediately before you are ready to install it. (Most replacement ES devices are packaged with leads electrically shorted together by conductive foam, aluminum foil or comparable conductive material.)
7. Immediately before removing the protective material from the leads of a replacement ES device, touch the protective material to the chassis or circuit assembly into which the device will be installed<sup>2</sup>

**CAUTION** : Be sure no power is applied to the chassis or circuit, and observe all other safety precautions.

8. Minimize bodily motions when handling unpackaged replacement ES devices. (Otherwise harmless motion such as the brushing together or your clothes fabric or the lifting of your foot from a carpeted floor can generate static electricity sufficient to damage an ES devices.

## PRODUCT SAFETY NOTICE DPR1001

Each precaution in this manual should be followed during servicing.

Components identified with the IEC symbol  in the parts list are special significance to safety. When replacing a component identified with , use only the replacement parts designated, or parts with the same ratings or resistance, wattage, or voltage that are designated in the parts list in this manual. Leakage-current or resistance measurements must be made to determine that exposed parts are acceptably insulated from the supply circuit before returning the product to the customer.

# LEAKAGE TESTING

Before returning the unit to the user, perform the following safety checks :

1. Inspect all lead dress to make certain that leads are not pinched or that hardware is not lodged between the chassis and other metal parts in the unit.
2. Be sure that any protective devices such as nonmetallic control knobs, insulating fish-papers, cabinet backs, adjustment and compartment covers or shields, isolation resistor-capacity networks, mechanical insulators, etc. Which were removed for the servicing are properly re-installed.
3. Be sure that no shock hazard exists ; check for leakage current using Simpson Model 229 Leakage Tester, standard equipment item No. 21641, RCA Model WT540A or use alternate method as follows : Plug the power cord directly into a 120 volt AC receptacle (do not use an Isolation Transformer for this test). Using two clip leads, connect a 1500 ohms, 10watt Resistor paralleled by a 0.15uF capacitor, in series with all exposed metal cabinet parts and a known earth ground, such as a water pipe or conduit. Use a VTVM or VOM with 1000 ohms per volt, or higher sensitivity to measure the AC voltage drop across the resistor. (See diagram) Move the resistor connection to each exposed metal part having a return path to the chassis (antenna, metal, cabinet, screw heads, knobs and control shafts, escutcheon, etc.) and measure the AC voltage drop across the resistor. (This test should be performed with the 0.35 volt RMS or more is excessive and indicates a potential shock hazard which must be corrected before returning the unit to the owner.

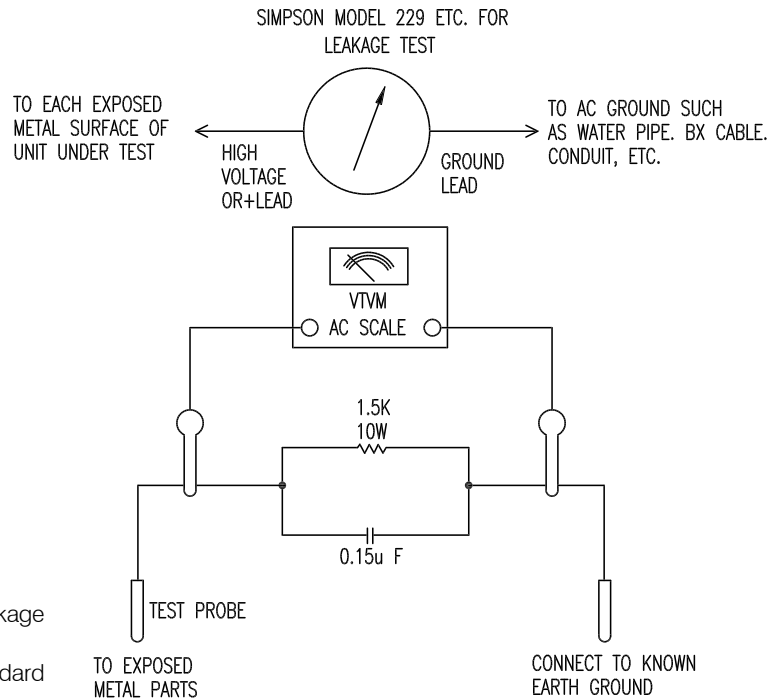

## BASIC SPECIFICATIONS

### Audio Section

Continuous Average Power (FTC)

All Channels: 50 Watts per channel @ 8 ohms, 1kHz, 0.19% THD

Power Output per EIA 490A: 65 Watts x 7 @ 8 ohms

Input Sensitivity/Impedance

Linear (High-Level) 200mV/47k ohms

Signal-to-Noise Ratio (IHF-A) 90dB

Surround System Adjacent Channel Separation

Pro Logic I, II 40dB

Dolby Digital 55dB

DTS 55dB

Frequency Response

@ 1W (+0dB, -3dB) 20Hz - 22kHz

Transient Intermodulation

Distortion (TIM) None

Negative Feedback None

### FM Tuner Section

Frequency Range 87.5MHz - 108MHz

Usable Sensitivity IHF 1.3µV/13.2dB

Signal-to-Noise Ratio Mono/Stereo 70dB/68dB

Distortion Mono/Stereo 0.2%/0.3%

Stereo Separation 40dB @ 1kHz

Selectivity ±400kHz, 70dB

Image Rejection 80dB

IF Rejection 90dB

### AM Tuner Section

Frequency Range 520kHz - 1710kHz

Signal-to-Noise Ratio 45dB

Usable Sensitivity Loop 500µV

Distortion 1kHz, 50% Mod 0.8%

Selectivity ±10kHz, 30dB

### Video Section

Television Format NTSC

Input Level/Impedance 1Vp-p/75 ohms

Output Level/Impedance 1Vp-p/75 ohms

Video Frequency Response (Composite and S) 10Hz - 8MHz (-3dB)

Video Frequency Response (Component) 10Hz - 30MHz (-3dB)

### General

Power Requirement AC 120V/60Hz

Power Consumption 7.6W standby, 550W @ rated output, all channels driven

Dimensions

Width 17.3 inches (440mm)

Height 4.75 inches (120mm)

Depth 18.75 inches (476mm)

Weight 17 lb (7.7kg)

Depth measurement includes knobs, buttons and terminal connections.

Height measurement includes feet and chassis.

All features and specifications are subject to change without notice.

Harman Kardon and Power for the Digital Revolution are registered trademarks of Harman International Industries, Incorporated.

**|||EzSet™** is a trademark of Harman International Industries, Incorporated (patent no. 5,386,478).

\*Manufactured under license from Dolby Laboratories.

"Dolby," "Pro Logic" and the Double-D symbol are trademarks of Dolby Laboratories. Confidential Unpublished Works. ©1992-1999 Dolby Laboratories, Inc. All rights reserved.

Surround EX is a jointly developed technology of THX and Dolby Laboratories, Inc., and is a trademark of Dolby. Used under authorization.

DTS, DTS Surround, DTS-ES and DTS Neo:6 are trademarks of Digital Theater Systems, Inc.

Cirrus and Cirrus Logic are trademarks of Cirrus Logic Inc.

VMAx is a registered trademark of Harman International Industries, Incorporated, and is an implementation of Cooper Bauck Transaural Stereo under patent license.

Logic 7 is a registered trademark of Harman International Industries, Incorporated.

TiVo is a registered trademark of TiVo, Inc.

ReplayTV is a registered trademark of SONICblue, Inc.

DETAILED SPECIFICATIONS

A) ANALOG INPUT, BASELINE AUDIO PARAMETERS (STEREO SURROUND MODE)

Measuring methods are based on IHF and IEC standard 268-3  
 Measurement conditions, unless otherwise noted :  
 Tone Off or Tone(Bass,Treble), Balance, EQ control : Center Position , Other SW's : OFF, Volume:Max  
 Nominal input level : 0dBFS sine wave PCM bitstream (Digital), 225mV sine wave (Analog)  
 Power figures should be kept minimum 10min., between 15 and 35 °C  
 Terminator : 1kohm for general purpose inputs  
 All Voltage Measurements are made with RMS detector, unless otherwise specified.  
 Filter : IHF-A filter  
 UUT= Unit Under Test.

Power supply : 120 V , 60 Hz

MARKETING UNIT RATINGS.	CONDITION	UNIT	VALUE
Rated Stereo Power Output	Both FL and FR Speaker amplifiers driven and loaded with Rated Resistive Load.	Watts/Ch	50
Rated 8 CH DIRECT Power Output	All Seven (FL,FR,C,SL,SR,SBL,SBR) Speaker amplifiers driven and loaded with Rated Resistive Load Impedance.	Watts/Ch	50
Rated Resistive Load	Resistive loads to be connected to Speaker Outputs using a 12 AWG Stranded Speaker Wire pair for each load resistor. Wire length should be approximately 10 feet.	Ohm	8 ohm, +/-1 %, Non-Inductive, 455 W

SPEAKER	AVAILABLE SPEAKER MODES
FRONT "L" AND "R" SPEAKERS	LARGE ALWAYS
SUBWOOFER OUTPUT	YES/NO

\*SUB-WOOFER SPKR:YES \*SPKR LEVEL:ALL 0dB \*TONE OUT

SPEAKER POWER AMPLIFIER SECTION

No	DESCRIPTION	INPUT	FREQ.	REMARK	UNIT	LIMIT	NOMONAL		
1	Input Sensitivity	Should be met by all Analog Stereo and 8 CH DIRECT Inputs	1kHz	Stereo and 8 CH DIRECT rated Power into Rated Resistive Load should be obtained by applying an input signal level with the specified range.	mV	225±40	225±20		8CH STEREO
2	RESIDUAL NOISE	Should be met by all Analog Stereo and 8CH DIRECT Inputs		VOL at min. 10Hz-22KHz BW, peak detector, all inputs terminated w/ 1 Kohm	mVpk	<3mV	<2mV		8 CH
				VOL at min. 10Hz-22KHz BW, peak detector, all inputs terminated w/ 1 Kohm	mVpk	<2.5mV	<1.5mV		STEREO
				VOL at max. 10Hz-22KHz BW, peak detector, all inputs terminated w/ 1 Kohm	mVpk	<10mVpk	<8mVpk		8 CH
				VOL at max. 10Hz-22KHz BW, peak detector, all inputs terminated w/ 1 Kohm	mVpk	<4mVpk	<2.5mVpk		STEREO
				VOL at max. 10Hz-22KHz BW, RMS, non-weighted, all inputs terminated w/ 1 Kohm	mVrms	<4mVrms	<3mVrms		8 CH
				VOL at max. 10Hz-22KHz BW, RMS, non-weighted, all inputs terminated w/ 1 Kohm	mVrms	<1mVrms	<0.75mVrms		STEREO
				VOL at max. 10Hz-22KHz BW, RMS, 'A Weighted', all inputs terminated w/ 1 Kohm	mVrms	<3mVrms	<2.5mVrms		8 CH
				VOL at max. 10Hz-22KHz BW, RMS, 'A Weighted', all inputs terminated w/ 1 Kohm	mVrms	<0.7mVrms	<0.5mVrms		STEREO
				VOL at max. 10Hz-22KHz BW, RMS, 'A Weighted', all inputs left un-terminated	mVrms	<3mVrms	<2.5mVrms		8 CH
VOL at max. 10Hz-22KHz BW, RMS, 'A Weighted', all inputs left un-terminated	mVrms	<0.7mVrms	<0.5mVrms		STEREO				
TOTAL HARMONIC DISTORTION (Rated Stereo Power Output -1dB)	Should be met by all Stereo Inputs	20Hz-20 KHz, Power out =Rated Power - 1 dB	Vol at Max, 10 Hz-22KHz Meas BW."A"WEIGHTED		%	<0.6	<0.45	20Hz	
								1k	
								20k	

DETAILED SPECIFICATIONS (CONT'D)

3	TOTAL HARMONIC DISTORTION (Rated 8 CH DIRECT Power Output - 1 dB)	8 CH DIRECT	20Hz-20 KHz, Power out =Rated Power - 1 dB	Vol at Max, 10 Hz-22KHz Meas BW."A"WEIGHTED	%	<0.6	<0.45	20Hz
								1k
								20k
	TOTAL HARMONIC DISTORTION (1 W Power Output)	Should be met by all Stereo Inputs	20Hz-10 KHz, Power out =1 W	Vol at Max, 10 Hz-22KHz Meas BW."A"WEIGHTED	%	<0.25	<0.15	20Hz
								1k
								20k
	TOTAL HARMONIC DISTORTION (1 W Power Output)	8 CH DIRECT	20Hz-10 KHz, Power out =1 W	Vol at Max, 10 Hz-22KHz Meas BW."A"WEIGHTED	%	<0.25	<0.15	20Hz
								1k
								20K
4	CONTINUOUS AVERAGE POWER: A) Stereo, 8 Ohm load, FL and FR driven.	CD	20 Hz	at 0.6% THD, 10 Hz-80 KHz measurement BW. Volume at Max.	W	>50	>53	
		CD	1kHz	at 0.6% THD, 10 Hz-80 KHz measurement BW. Volume at Max.	W	>50	>53	
		CD	20 KHz	at 0.6% THD, 10 Hz-80 KHz measurement BW. Volume at Max.	W	>50	>53	
	CONTINUOUS AVERAGE POWER: B) All 7 Channels Driven, 8 ohms	8 CH DIRECT	20 Hz	at 0.6% THD, 10 Hz-80 KHz measurement BW. Volume at Max.	W	>50	>53	
		8 CH DIRECT	1kHz	at 0.6% THD, 10 Hz-80 KHz measurement BW. Volume at Max.	W	>50	>53	
		8 CH DIRECT	20 KHz	at 0.6% THD, 10 Hz-80 KHz measurement BW. Volume at Max.	W	>50	>53	
5	IMD(SMPTE)	Should be met by CH DIRECT Inputs	Sine wave # 1 f =60Hz. Ampl=4, sine wave # 2 f= 7 KHz. Ampl=1	30 step Sweep of Gen to Drive to Pk-Pk value of sine rated power	%	<0.6	<0.4	
		Should be met by all Analog Stereo Inputs	Sine wave # 1 f =60Hz. Ampl=4, sine wave # 2 f= 7 KHz. Ampl=1	30 step Sweep of Gen to Drive to Pk-Pk value of sine rated power	%	<0.6	<0.4	
	Should be met by CH DIRECT Inputs	1kHz	Referred to Rated Output Power, Vol at max, all inputs terminated w/ 1 Kohm. Should be measured with a 10 Hz-22 KHz BW, RMS noise reading	dB	>70	>75	8 CH	
							TAPE	
	Should be met by all Analog Stereo Inputs	1kHz	Referred to Rated Output Power, Vol at max, all inputs terminated w/ 1 Kohm. Should be measured with a 10 Hz-22 KHz BW, RMS noise reading	dB	>80	>85	CD	
							VID 1	
							VID 2	
							VID 3	
							VID 4	
	DVD							
Should be met by CH DIRECT Inputs	1kHz	Referred to 1W Out.Vol at max, all inputs terminated w/ 1 Kohm. Should be measured with a 10 Hz-22 KHz BW, RMS noise reading	dB	>55	>60	8 CH		

# SPECIFICATIONS

6	S/N RATIO,IHF-A FILTER	Should be met by 8CH DIRECTInputs	1kHz	Referred to 1W Out.Vol at max, all inputs terminatedw/ 1 Kohm. Should be measured with a 10 Hz-22 KHz BW, RMS noise reading	dB	>55	>60		TAPE	
									CD	
									VID 1	
									VID 2	
									VID 3	
									VID 4	
			DVD							
			Should be met by 8CH DIRECTInputs	1kHz	Referred to Rated Output Power, Vol at max, all inputs left un-terminated. Should be measured with a 10Hz-22 KHz BW, RMS noise reading	dB	>70	>75		8 CH
			Should be met by all Analog Stereo Inputs	1kHz	Referred to Rated Output Power, Vol at max, all inputs left un-terminated. Should be measured with a 10Hz-22 KHz BW, RMS noise reading	dB	>80	>85		TAPE
	CD									
	VID 1									
	VID 2									
	VID 3									
	VID 4									
	DVD									
7	CHANNEL SEPARATION: Zterm = 1KW/1000pF IHF-A FILTER	Should be met by all Analog Stereo and 8 CH DIRECT Inputs	100Hz	Vol at Max, Gen amplitude adjusted to obtain R/O-3dB, measured w/ AP's Xtalk mode. Driving every channel individually. Undriven channels should be terminated w/1 kOhm.Use 10Hz-22KHz BW	dB	>55	>60		stereo	
			1kHz	Vol at Max, Gen amplitude adjusted to obtain R/O-3dB, measured w/ AP's Xtalk mode. Driving every channel individually. Undriven channels should be terminated w/1 kOhm.Use 10Hz-22KHz BW	dB	>60	>65		8 ch	
			10kHz	Vol at Max, Gen amplitude adjusted to obtain R/O-3dB, measured w/ AP's Xtalk mode. Driving every channel individually. Undriven channels should be terminated w/1 kOhm.Use 10Hz-22KHz BW	dB	>50	>60		stereo	
									8 ch	
8	FUNCTION CROSSTALK, (Measured on all Channels) IHF-A FILTER	All Analog Stereo and 8 CH DIRECT Inputs	1 kHz	Volume at Max. Apply Sinewave Signal Gen amplitude to the tested input, to obtain R/O-3dB at the speaker outputs.Record the output level as the reference output. Then, scroll thru the other possible stereo inputs, and measure the output level. Compute t	dB	>70	>75		stereo	
		All Analog Stereo and 8 CH DIRECT Inputs	10 kHz	Volume at Max. Apply Sinewave Signal Gen amplitude to the tested input, to obtain R/O-3dB at the speaker outputs. Record the FL and FR speaker output level as the reference output. Scroll thru other stereo inputs, and measure the output level. Compute th	dB	> 55	>75		8 ch	
		AM/FM Tuner Input	1 KHz	Apply an FM Stereo RF input thru a 50->75 ohm dummy antenna (98 MHz carrier, 75 KHz modulation, 1 KHz tone, 72 dBuV level). Then set UUT to FM Stereo, 98MHz. Set Volume control to 10 dB below Max. Record the FL and FR speaker output level as the refere	dB	> 75	>85			
9	FREQUENCY RESPONSE	8 CH DIRECT Inputs	To find the point in the Frequency Response Curve, where Output Level falls by 3 dB, referred to the 1	Should be met with Volume at Max (50 mV input) Use 10Hz-500KHz BW	Hz	20 Hz-18K kHz	10 Hz-20 kHz		Vol.max input:50 mV	
		All Analog Stereo Inputs	To find the point in the Frequency Response Curve, where Output Level falls by 3 dB, referred to the 1 KHz point.	Should be met with Volume at Max (50 mV input), and also with Volume at 40 dB below Max (5 V input).	Hz	10 Hz-20 kHz	5 Hz-22 kHz	STEREO		
								8CH	Vol.-40 input:5V	
								STEREO		
							8CH			
10	POWER BANDWIDTH - 3dB	CD	Tested at Stereo Mode Rated Power -3dB --> THD 0.6%	Tested in Stereo Mode, at Stereo Rated Power -3dB. Find the Input Sinawave Frequency Point where THD increases to 0.6% . Record the Frequency.	Hz~kHz	20-20kHz	20-22kHz		TAPE	
									CD	
									VID 1	
									VID 2	
									VID 3	
									VID 4	
			DVD							
			8 CH DIRECT Inputs	Tested at 8 CH DIRECT Mode Rated Power -3dB --> THD 0.6%	Tested in 8 CH DIRECT Mode, at 8CH DIRECT Rated Power -3dB. Find the Input Sinawave Frequency Point where THD increases to 0.6% . Record the Frequency.	Hz~kHz	20-20kHz	20-22kHz		

DETAILED SPECIFICATIONS (CONT'D)

B) DIGITAL INPUT, BASELINE AUDIO PARAMETERS (STEREO SURROUND MODE)

Measuring methods are based on IHF and IEC standard 268-3

Measurement conditions, unless otherwise noted :

Output resistive load = (8) ohms / All channels loaded.

Tone Off or Tone(Bass,Treble), Balance, EQ control : Center Position , Other SW's : OFF, Volume:Max

All Voltage Measurements are made with RMS detector, unless otherwise specified.

Filter : IHF-A filter

R/O = Rated Output, which is 50 W into 8 ohm resistive load, for PCM Digital inputs.

UUT= Unit Under Test.

All measurements are made in Stereo mode, at FL and FR Speaker Output jacks, unless otherwise noted.

Power supply : 120 V , 60 Hz

MARKETING UNIT RATINGS.	CONDITION	UNIT	VALUE
Rated Stereo Power Output	Both FL and FR Speaker amplifiers driven and loaded with Rated Resistive Load.	Watts/Ch	50
Rated 6 CH DIRECT Power Output	All seven(FL,FR,C,SL,SR ,SBL,SBR ) Speaker amplifiers driven and loaded with Rated Resistive Load Impedance.	Watts/Ch	50
Rated Resistive Load	Resistive loads to be connected to Speaker Outputs using a 12 AWG Stranded Speaker Wire pair for each load resistor. Wire length should be approximately 10 feet.	Ohm	8 ohm, +/- 1 %, Non-Inductive, 455 W

SPEAKER	STEREO MODE AVAILABLE SPEAKER SETTINGS
FRONT "L" AND "R" SPEAKERS	LARGE/SMALL
SUBWOOFER OUTPUT	YES/NO

SPEAKER	MULTICHANNEL AVAILABLE SPEAKER MODES
FRONT "L" AND "R" SPEAKERS	LARGE/SMALL
CENTER SPEAKER	LARGE/SMALL/NONE
SURROUND "L" AND "R" SPEAKERS	LARGE/SMALL/NONE
SUBWOOFER OUTPUT	YES/NO

Digital Input data is a 44.1 KHz sampling rate, 16 bit, no Pre-emphasis, PCM bitstream.

FRONT AMP SECTION

No	DESCRIPTION	INPUT	REMARK	UNIT	LIMIT	NOMINAL
1	Gain Difference between Analog and Digital Input	Coaxial 1	With a 0 dBFS, 1 KHz PCM bitstream, and Main Volume at 20 dB below Max, the Output Voltage at FL and FR speaker outputs should be the same as when, applying a 2 Volt, 1 KHz sinewave amplitude into an analog Stereo Input. Read the dB difference between	dB	< 2 dB	< 1 dB
2	Dynamic Range	Coaxial 1	With a 0 dBFS, 1 KHz sinewave PCM bitstream, and Main Volume at 20 dB below Max, set meter to read THD+N Ampl, with dBr units. Use 'A Weighting' filter, 10 Hz-80 KHz BW. Record the Output Voltage at FL and FR speaker outputs to be the 0 dBr Reference val	dB	>85	> 90
3	RESIDUAL NOISE	Coaxial 1	With Digital Generator amplitude at -999 dBFS (Generator turned off), 1 KHz sinewave PCM bitstream, and Main Volume at 20 dB below Max, set meter to read Amplitude,10 Hz-22 KHz BW. Take Amplitude readings on both FL and FR Speaker Outputs.	mVrms	<1	<0.5
4	TOTAL HARMONIC DISTORTION	Coaxial 1	20 Hz With a 0 dBFS, 1 KHz sinewave PCM bitstream, and Main Volume at 20 dB below Max, set meter to read THD+N , with % units. Use 10 Hz-80 KHz BW. Read THD+N Ratio, with dBr units on both FL and FR Speaker Outputs. IHF-A FILTER	%	<0.25	<0.15



## DETAILED SPECIFICATIONS (CONT'D)

4	TOTAL HARMONIC DISTORTION	Coaxial 1	20 Hz	With a 0 dBFS, 1 KHz sinewave PCM bitstream, and Main Volume at 20 dB below Max, set meter to read THD+N, with % units. Use 10 Hz-80 KHz BW. Read THD+N Ratio, with dBr units on both FL and FR Speaker Outputs.IHF-A FILTER	%	<0.25	<0.15
			1 KHz	With a 0 dBFS, 20 Hz sinewave PCM bitstream, and Main Volume at 20 dB below Max, set meter to read THD+N, with % units. Use 10 Hz-80 KHz BW. Read THD+N Ratio, with dBr units on both FL and FR Speaker Outputs.IHF-A FILTER	%	<0.6	<0.4
			20 KHz	With a 0 dBFS, 20 KHz sinewave PCM bitstream, and Main Volume at 20 dB below Max, set meter to read THD+N Ratio, with % units. Use 10 Hz-80 KHz BW. Read THD+N Ratio, on both FL and FR Speaker Outputs.	%	<0.25	<0.15
5	IMD(SMPTE)	Coaxial 1	Sine wave # 1 f =80Hz. Ampl=4, sine wave # 2 f= 2 KHz. Ampl=1	With a 0 dBFS, SMPTE (80 Hz-4X:2 KHz-1X) waveform PCM bitstream, and Main Volume at 20 dB below Max, set meter to read SMPTE/DIN Distortion, with % units. Read SMPTE/DIN Distortion, on both FL and FR Speaker Outputs.	%	0.6	0.4
6	S/N RATIO,IHF-A FILTER	Coaxial 1	With a 0 dBFS, 1 KHz sinewave PCM bitstream, and Main Volume at 20 dB below Max, record the Output Voltage at FL and FR speaker outputs to be the 0 dBr Reference value. Set Digital Generator amplitude to -999 dBFS (Generator turned off),Then set meter t	dB	>85	> 90	
		Coaxial 1	With a 0 dBFS, 1 KHz sinewave PCM bitstream, and Main Volume adjusted to obtain 1 W output into an 8 ohm load. Record the Voltage at FL and FR speaker outputs to be the 0 dBr Reference value. Set Digital Generator amplitude to -999 dBFS (Generator Output	dB	> 70	>75	
7	CHANNEL SEPARATION: Zterm = 1KW/1000pF	Coaxial 1	100Hz	With a 0 dBFS, 100 Hz sinewave PCM bitstream, and Main Volume at 20 dB below Max, set meter to read Crosstalk, with dB units. Use 10 Hz-80 KHz BW. Read Crosstalk, when driving FL only, and measuring FR. Then, read Crosstalk, when driving FR only, and me	dB	>60	>65
			1 KHz	With a 0 dBFS, 1 KHz sinewave PCM bitstream, and Main Volume at 20 dB below Max, set meter to read Crosstalk, with dB units. Use 10 Hz-80 KHz BW. Read Crosstalk, when driving FL only, and measuring FR. Then, read Crosstalk, when driving FR only, and mea	dB	>60	> 65
			10 KHz	With a 0 dBFS, 10 KHz sinewave PCM bitstream, and Main Volume at 20 dB below Max, set meter to read Crosstalk, with dB units. Use 10 Hz-80 KHz BW. Read Crosstalk, when driving FL only, and measuring FR. Then, read Crosstalk, when driving FR only, and me	dB	>50	>60

## DETAILED SPECIFICATIONS (CONT'D)

8	FREQUENCY RESPONSE	Coaxial 1	20 Hz	With a 0 dBFS, 1 KHz sinewave PCM bitstream, and Main Volume at 20 dB below Max, record the Output Voltage at FL and FR speaker outputs to be the 0 dBr, 1 KHz Reference value. Set meter to read Amplitude with dBr units, and a 10 Hz-500 KHz BW. Then, ch	dBr	> -0.7	> -0.3	
		Coaxial 1	20 KHz	With a 0 dBFS, 1 KHz sinewave PCM bitstream, and Main Volume at 20 dB below Max, record the Output Voltage at FL and FR speaker outputs to be the 0 dBr, 1 KHz Reference value. Set meter to read Amplitude with dBr units, and a 10 Hz-500 KHz BW. Then, ch	dBr	> -3	> -2	

Digital Input data is a 96 KHz sampling rate, 24 bit, no Pre-emphasis, PCM bitstream.

## FRONT AMP SECTION

No	DESCRIPTION	INPUT	REMARK	UNIT	LIMIT	NOMINAL		
1	Dynamic Range	Coaxial 1	With a 0 dBFS, 1 KHz sinewave PCM bitstream, and Main Volume at 20 dB below Max, set meter to read THD+N Ampl, with dBr units. Use 'A Weighting' filter, 10 Hz-80 KHz BW. Record the Output Voltage at FL and FR speaker outputs to be the 0 dBr Reference val	dB	>90	>93		
2	RESIDUAL NOISE	Coaxial 1	With Digital Generator amplitude at -999 dBFS (Generator turned off), 1 KHz sinewave PCM bitstream, and Main Volume at 20 dB below Max, set meter to read Amplitude, 10 Hz-22 KHz BW. Take Amplitude readings on both FL and FR Speaker Outputs.	mVrms	<1	<0.8		
		Coaxial 1	With Digital Generator amplitude at -999 dBFS (Generator turned off), 1 KHz sinewave PCM bitstream, and Main Volume at 20 dB below Max, set meter to read Amplitude, 10 Hz-80 KHz BW. Take Amplitude readings on both FL and FR Speaker Outputs.	mVrms	<1.5	<1		
		Coaxial 1	With Digital Generator amplitude at -999 dBFS (Generator turned off), 1 KHz sinewave PCM bitstream, and Main Volume at 20 dB below Max, set meter to read Amplitude, 10 Hz-22 KHz BW. Take Amplitude readings on both FL and FR Speaker Outputs.	mVpk	<3	<2		
3	TOTAL HARMONIC DISTORTION	Coaxial 1	20 Hz	With a 0 dBFS, 1 KHz sinewave PCM bitstream, and Main Volume at 20 dB below Max, set meter to read THD+N, with % units. Use 10 Hz-22 KHz BW. Read THD+N Ratio, with dBr units on both FL and FR Speaker Outputs.	%	<0.25	<0.15	
			1 KHz	With a 0 dBFS, 20 Hz sinewave PCM bitstream, and Main Volume at 20 dB below Max, set meter to read THD+N, with % units. Use 10 Hz-22 KHz BW. Read THD+N Ratio, with dBr units on both FL and FR Speaker Outputs.	%	0.6	0.4	

			20 KHz	With a 0 dBFS, 20 KHz sinewave PCM bitstream, and Main Volume at 20 dB below Max, set meter to read THD+N Ratio, with % units. Use 10 Hz-22 KHz BW. Read THD+N Ratio, on both FL and FR Speaker Outputs.	%	<0.25	<0.15	
4	IMD(SMPTE)	Coaxial 1	Sine wave # 1 f =80Hz. Ampl=4, sine wave # 2 f= 2 KHz. Ampl=1	With a 0 dBFS, SMPTE (80 Hz-4X:2 KHz-1X) waveform PCM bitstream, and Main Volume at 20 dB below Max, set meter to read SMPTE/DIN Distortion, with % units. Read SMPTE/DIN Distortion, on both FL and FR Speaker Outputs.	%	0.6	0.4	
5	S/N RATIO,IHF-A FILTER	Coaxial 1		With a 0 dBFS, 1 KHz sinewave PCM bitstream, and Main Volume at 20 dB below Max, record the Output Voltage at FL and FR speaker outputs to be the 0 dBr Reference value. Set Digital Generator amplitude to -999 dBFS (Generator turned off),Then set meter t	dB	>85	> 90	
		Coaxial 1		With a 0 dBFS, 1 KHz sinewave PCM bitstream, and Main Volume adjusted to obtain 1 W output into an 8 ohm load. Record the Output Voltage at FL and FR speaker outputs to be the 0 dBr Reference value. Set Digital Generator amplitude to -999 dBFS (Generator turned off),Then set meter t	dB	> 70	>75	
6	FREQUENCY RESPONSE	Coaxial 1	20 Hz	With a 0 dBFS, 1 KHz sinewave PCM bitstream, and Main Volume at 20 dB below Max, record the Output Voltage at FL and FR speaker outputs to be the 0 dBr, 1 KHz Reference value. Set meter to read Amplitude with dBr units, and a 10 Hz-500 KHz BW. Then, ch	dBr	> -0.7	> -0.3	
		Coaxial 1	20 KHz	With a 0 dBFS, 1 KHz sinewave PCM bitstream, and Main Volume at 20 dB below Max, record the Output Voltage at FL and FR speaker outputs to be the 0 dBr, 1 KHz Reference value. Set meter to read Amplitude with dBr units, and a 10 Hz-500 KHz BW. Then, ch	dBr	> -3	> -2	

## DETAILED SPECIFICATIONS (CONT'D)

**TUNER SECTION**

Measuring methods in conformity with IEC standard 315

Measurements condition FM : Radio frequency = 98MHz, Audio frequency = 1kHz

Reference level = 1mV on ( 75ohms , 300ohms )

Deviation ■ MONO = 75kHz, Stereo = 67.5kHz 7.5kHz MONO = 40kHz, Stereo = 40kHz 7.5kHz

Test Point : TP 1 = 90MHz, TP 2 = 98MHz, TP 3 = 106MHz

Filter = B.P.F at STEREO

**Power supply : 120 V , 60 Hz**

## ● FM SECTION

No	DESCRIPTION	UNIT	LIMIT	NOMINAL			
1	Tuning Range	Low ~ High	MHz	87.5~108M			
	Step	Auto/Man.	kHz	100			
2	Usable Sensitivity S/N=( 26 , 30 )dB	TP 1	dBf	> 17.2	> 14.2		
		TP 2	dBf	> 17.2	> 14.2		
		TP 3	dBf	> 17.2	> 14.2		
3	Full Limiting Sens	Output = -3dB	dBf	> 15.2	> 12.2		
4	Auto Stop Level	Stereo	dBf	33.2 +/- 6	33.2 +/- 5		
5	Auto Scan Error	Stereo	kHz	+/- 20/20	+/- 40/40		
6	S/N Ratio IHF-A"Filter	Mono	dB	> 65	> 70		
		Stereo	dB	> 63	> 68		
7	Total Harmonic Distortion	Mono	%	> 0.5	> 0.3		
		Stereo	%	> 0.8	> 0.5		
8	( 50 , 46 )dB Quieting Sens	Mono	dBf	< 23.2	< 20.2		
		Stereo	dBf	< 48.3	< 45.3		
9	Channel Separation	100Hz	dB	> 35	> 40		
		1kHz	dB	> 35	> 40		
		10kHz	dB	> 30	> 35		
10	Frequency Response at 1,-3dB	Mono	Hz	20~14K	10~15K		
11	Spurious Response	Mono	dB	> 60	> 70		
12	IF Rejection	TP 1	dB	> 70	> 80		
13	Image Rejection	TP 3	dB	> 60	> 70		
14	AM Rejection Ratio	Mono	dB	> 50	> 55		
15	RF Intermodulation	Mono	dB				
16	Capture Ratio	Mono	dB	< 3	< 2		
17	Alternative ch Selectivity	400kHz	dB	> 65	> 70		
19	Output Level Mono	Mono	mV	500 +/- 150	500 +/- 100		

Measuring methods in conformity with IEC standard 315

Measurements condition AM - MW : Radio frequency = 1000/999kHz, Audio frequency = 400Hz

LW : Radio frequency = 207kHz, Audio frequency = 400Hz

Reference level = 5mV/m,10mV/m on 50ohms

Modulation = 30%

Test Point : MW

TP 1 = (600)kHz TP 2=(1000)kHz TP 3=(1400)kHz

LW TP1 = 162kHz, TP2 = 207kHz, TP3 = 252kHz

## DETAILED SPECIFICATIONS (CONT'D)

## ● AM SECTION

## DPR1001

No	DESCRIPTION		UNIT	LIMIT	NOMINAL			
1	Tuning Cover Range	Low ~ High MW	kHz	520~1710				
	Step	LW	kHz					
		Auto/Man.	kHz	10				
2	Usable Sensitivity S/N=20dB	MW	TP 1	uV/m	> 2000	> 1000		
			TP 2	uV/m	> 2000	> 1000		
			TP 3	uV/m	> 2000	> 1000		
		LW	TP 1	uV/m				
			TP 2	uV/m				
			TP 3	uV/m				
3	S/N Ratio Input=10mV/m	MW	dB	> 35	> 40			
		LW	dB					
4	Total Harmonic Distortion	MW	%	> 3.0	> 1.5			
5	Over Load Distortion 5mV 80% MOD	MW	%	> 10	> 5			
6	Frequency Response at -6dB	MW	Hz	100~2K	80~2.3K			
		LW	Hz					
7	Selectivity 10kHz/9kHz	MW	dB	> 20	> 25			
		LW	dB					
8	AGC Figure of Merit	Input 100mV	dB	> 50	> 55			
9	Image Rejection	MW = TP 3	dB	> 28	> 33			
		LW = TP 3	dB					
10	Whistle Modulation Input=1mV/m	2IF	%	> 15	> 10			
		3IF	%	> 15	> 10			
11	Auto Stop Level	MW	uV/m	1000(+/- 6dB)	1000 (+/- 5dB)			
		LW	uV/m					
12	Tuned Level	MW	uV/m	1000 (+/- 6dB)	1000 (+/- 5dB)			
		LW	uV/m					
13	Output Level ( input 10mV )	MW	mV	160 +/- 40	160 +/- 30			

## FRONT PANEL CONTROLS

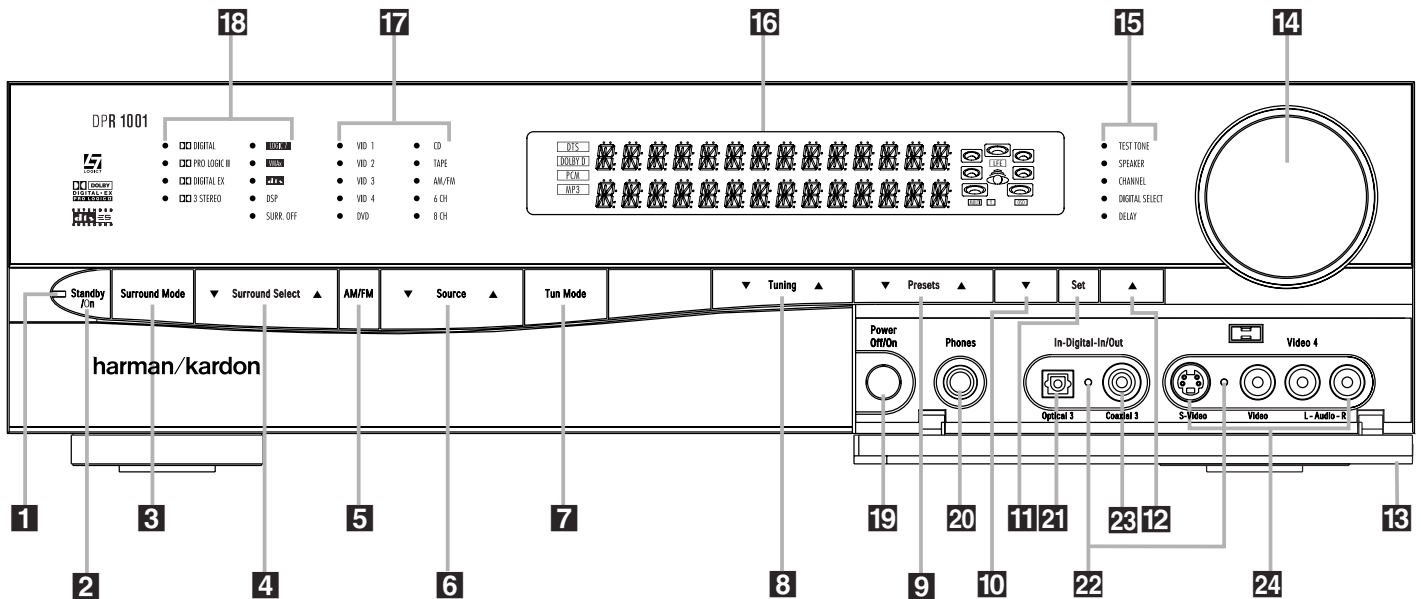

- |                                  |   |  |
|----------------------------------|---|--|
| <b>1</b> Power Indicator         | <b>10</b> ▼ Button                        | <b>19</b> Main Power Switch              |
| <b>2</b> Standby/On Button       | <b>11</b> Set Button                      | <b>20</b> Headphone Jack                 |
| <b>3</b> Surround Mode Selector  | <b>12</b> ▲ Button                        | <b>21</b> Digital Optical 3 Input        |
| <b>4</b> Surround Select Button  | <b>13</b> Door                            | <b>22</b> Input/Output Status Indicators |
| <b>5</b> AM/FM Selector          | <b>14</b> Volume Control                  | <b>23</b> Digital Coax 3 Jack            |
| <b>6</b> Input Source Selector   | <b>15</b> System Configuration Indicators | <b>24</b> Video 4 Input/Output Jacks     |
| <b>7</b> Tuning Mode Selector    | <b>16</b> Main Information Display        |  |
| <b>8</b> Tuning Selector         | <b>17</b> Input Indicators                |  |
| <b>9</b> Preset Station Selector | <b>18</b> Surround Mode Indicators        |  |

**NOTE:** To make it easier to follow the installation instructions that refer to this illustration, a larger copy may be downloaded from the Product Support section at [www.harmankardon.com](http://www.harmankardon.com).

**1 Power Indicator:** This LED turns red when the unit is in the Standby mode to signal that the unit is ready to be turned on. When the unit is in operation, the indicator will turn green.

**2 Standby/On Button:** When the Main Power Switch **19** is "ON," press this button to turn on the DPR 1001; press it again to turn the unit off. The Power Indicator **1** will turn green when the unit is on.

**NOTE:** The Main Power Switch **19** must be turned on before this button will operate.

**3 Surround Mode Selector:** Press this button to choose a surround processing format category by scrolling through the list of available formats as indicated in the Surround Mode Indicators **18**.

These format categories are: Dolby surround modes, DTS Digital modes, DTS Neo:6 modes, Logic 7 modes, DSP modes and Stereo modes. Once you have selected a format category, use the Surround Select Button **4** to choose a specific mode within the overall category.

**4 Surround Select Button:** After choosing a surround processing format category by using the Surround Mode Selector **3**, press this button to scroll through the list of available modes for that format category. For example, to select the 7.1 Logic 7 Cinema mode, press the Surround Mode Selector **3** until the indicator next to Logic 7 **18** is lit. Then press the Surround Select Button **4** to scroll through the available choices until the desired mode appears in the Main Information Display **16**. (For more information see page 26.)

**5 AM/FM Selector:** Pressing this button will automatically switch the DPR 1001 to the Tuner mode. Pressing it again will switch between the AM and FM frequency bands. (See page 28 for more information on the tuner.)

**6 Input Source Selector:** Press this button to change the input by scrolling up or down through the list of input sources.

**7 Tuning Mode Selector:** This button is used to switch back and forth between the Auto and Manual tuning modes. In Auto mode, you may use the Tuning Selector **8** to scan through stations with an acceptable signal. In Manual mode, you may use the Tuning Selector **8** to step through one frequency increment at a time.

## FRONT PANEL CONTROLS (CONT'D)

This button is also used to switch between Stereo and Mono modes for FM radio reception. When weak reception is encountered, press the button to switch to the Mono mode. Press it again to switch back to Stereo mode. (See page 28 for more information on using the tuner.)

**8 Tuning Selector:** Press the left side of the button to tune lower-frequency stations and the right side of the button to tune higher-frequency stations.

In Manual tuning mode, tap the button lightly and the tuner will step up one frequency increment per button press. When the button is held for a few seconds, the unit will quickly advance through the frequency band. Release it and the tuner will stop. In Auto tuning mode, each press of the button will search for the next station with an acceptable signal. Press and hold the button to skip through the acceptable stations. When the button is released, the tuner will not stop until it reaches a station with an acceptable signal.

To switch back and forth between the Auto and Manual tuning modes, press the **Tuning Mode Selector 7**.

**9 Preset Station Selector:** Press this button to scroll up or down through the list of stations that have been entered into the preset memory. (See page 28 for more information on tuner programming.)

**10 ▼ Button:** Use this button to scroll through the System Configuration modes indicated on the front panel: i.e., Test Tone, Speaker, Channel, Digital Select and Delay. Press the **Set Button 11** to select a configuration mode, and use this button or the **▲ Button 12** to scroll through the available adjustments for each System Configuration mode. (See pages 17–23 for more information on configuring the DPR 1001.)

**11 Set Button:** Press this button to access the configuration menus for Test Tone, Speakers Channel Trim, Digital Input Select or Delay. After pressing the button, use the **▲/▼ Buttons 10/12** to select the desired menu. (See pages 17–23 for more information.)

**12 ▲ Button:** Use this button to scroll through the System Configuration modes indicated on the front panel: i.e., Test Tone, Speaker, Channel, Digital Select and Delay. Press the **Set Button 11** to select a configuration mode, and use this button or the **▼ Button 10** to scroll through the available adjustments for each System Configuration mode. (See pages 17–23 for more information on configuring the DPR 1001.)

**13 Door:** Gently pull the upper right corner of this door, indicated by the word "Open", toward you to reveal additional front panel jacks and controls.

**14 Volume Control:** Turn this knob clockwise to increase the volume, counterclockwise to decrease the volume. If the DPR 1001 is muted, adjusting the volume control will automatically release the unit from the silenced condition.

**15 System Configuration Indicators:** One of these indicators will light, after the **Set Button 11** has been pressed, to indicate which configuration option is in use. Press the **▲/▼ Buttons 10/12** to change the selection. (See pages 17–23 for more information.)

**16 Main Information Display:** This display delivers messages and status indications to help you operate the receiver. (See page 7 for a complete explanation of the Main Information Display.)

**17 Input Indicators:** An LED will light to the left of the input that is currently the input source for the DPR 1001.

**18 Surround Mode Indicators:** An LED will light in front of the surround mode that is currently in use.

**19 Main Power Switch:** Press this button in to apply power to the DPR 1001. When the switch is pressed in, the unit is placed in a Standby mode, as indicated by the red **Power Indicator 1**. This button *must* be pressed in to operate the unit. To turn the unit off and prevent the use of the remote control, this switch should be pressed until it pops out from the front panel.

**NOTE:** This switch is normally left in the "ON" position.

**20 Headphone Jack:** This jack may be used to listen to the DPR 1001's output through a pair of headphones. Be certain that the headphones have a standard 1/4" stereo phone plug. The main room speakers will automatically be turned off when the headphone jack is in use.

**21 Digital Optical 3 Input:** Connect the optical digital audio output of an audio or video product to this jack. When the input is not in use, be certain to keep the plastic cap installed to avoid dust contamination that might degrade future performance.

**22 Input/Output Status Indicators:** These LED indicators will normally light green to show that the front panel **Digital Coax 3 Jack 23** or **Video 4 Input/Output Jacks 24** are operating as inputs. When either of these jacks has been configured for use as an output, the indicator will turn red to show that the jack may be used for recording. (See page 18 or 29 for more information on configuring the front panel jacks as outputs, rather than inputs.)

**23 Digital Coax 3 Jack:** This jack is normally used for connection to the output of portable audio devices, video game consoles or other products that have a coax digital audio jack. It may also be configured as an output jack, to feed a digital signal to a CD-R, MiniDisc or other digital recording device. (See page 18 or 29 for information on configuring the Digital Coax 3 Jack as an output.)

**24 Video 4 Input/Output Jacks:** These audio/video jacks may be used for temporary connection to video games or portable audio/video products such as camcorders and portable audio players. These jacks may also be configured as an output to feed an analog audio/video signal to a VCR, camcorder, tape deck or other recording device. (See page 18 or 29 for information on configuring the Video 4 jacks as outputs.)

## REAR PANEL CONNECTIONS

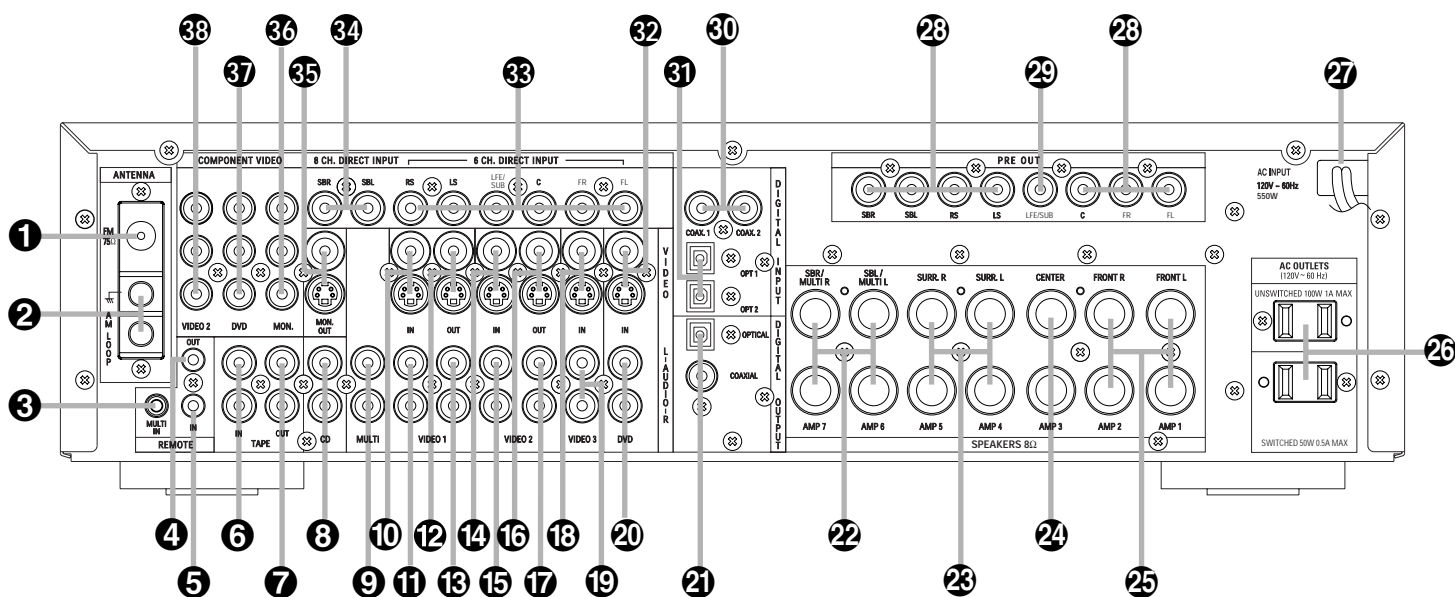

- |                          |  |  |
|--------------------------|--|--|
| 1 FM Antenna             | 14 Video 2 Video Inputs                    | 27 AC Power Cord                         |
| 2 AM Antenna             | 15 Video 2 Audio Inputs                    | 28 Preamp Outputs                        |
| 3 Multiroom IR Input     | 16 Video 2 Video Outputs                   | 29 LFE/Subwoofer Output                  |
| 4 Remote IR Output       | 17 Video 2 Audio Outputs                   | 30 Coaxial Digital Audio Inputs          |
| 5 Remote IR Input        | 18 Video 3 Video Inputs                    | 31 Optical Digital Audio Inputs          |
| 6 Tape Inputs            | 19 Video 3 Audio Inputs                    | 32 DVD Video Inputs                      |
| 7 Tape Outputs           | 20 DVD Audio Inputs                        | 33 6-Channel Direct Inputs               |
| 8 CD Inputs              | 21 Digital Audio Outputs                   | 34 8-Channel Direct Inputs               |
| 9 Multiroom Outputs      | 22 Surround Back/Multiroom Speaker Outputs | 35 Video Monitor Outputs                 |
| 10 Video 1 Video Inputs  | 23 Surround Speaker Outputs                | 36 Video Monitor Component Video Outputs |
| 11 Video 1 Audio Inputs  | 24 Center Speaker Outputs                  | 37 DVD Component Video Inputs            |
| 12 Video 1 Video Outputs | 25 Front Speaker Outputs                   | 38 Video 2 Component Video Inputs        |
| 13 Video 1 Audio Outputs | 26 AC Accessory Outlets                    |  |

To assist you in making the correct connections for multichannel input, output and speaker connections, all connection jacks and terminals have been color-coded in conformance with the CEA standards as follows:

Front Left: White  
 Front Right: Red  
 Center: Green  
 Surround Left: Blue  
 Surround Right: Gray  
 Surround Back Left: Brown  
 Surround Back Right: Tan

Subwoofer: Purple  
 Digital Audio: Orange  
 Composite Video: Yellow  
 Component Video "Y": Green  
 Component Video "Pr": Red  
 Component Video "Pb": Blue

**NOTE:** To make it easier to follow the installation instructions that refer to this illustration, a larger copy may be downloaded from the Product Support section at [www.harmankardon.com](http://www.harmankardon.com).

- |  |   |  |
|--|---|--|
| <p><b>1 FM Antenna:</b> Connect the supplied indoor (or an optional external) FM antenna to this terminal.</p> <p><b>2 AM Antenna:</b> Connect the AM loop antenna supplied with the receiver to these terminals. Connect the black antenna wire marked GND to the top terminal screw on the DPR with the grounding symbol.</p> <p><b>3 Multiroom IR Input:</b> Connect the output of an IR sensor in a remote room to this jack to operate the DPR 1001's multiroom control system. (See pages 31 for more information on multiroom systems.)</p> <p><b>4 Remote IR Output:</b> This connection permits the</p> | <p>IR sensor in the receiver to serve other remote controlled devices. Connect this jack to the "IR IN" jack on Harman Kardon (or other compatible) equipment.</p> <p><b>5 Remote IR Input:</b> If the DPR 1001's front panel IR sensor is blocked due to cabinet doors or other obstructions, an external IR sensor may be used. Connect the output of the sensor to this jack.</p> <p><b>6 Tape Inputs:</b> Connect these jacks to the PLAY/OUT jacks of an audio recorder.</p> <p><b>7 Tape Outputs:</b> Connect these jacks to the RECORD/INPUT jacks of an audio recorder.</p> | <p><b>8 CD Inputs:</b> Connect these jacks to the output of a compact disc player or changer.</p> <p><b>9 Multiroom Outputs:</b> Connect these jacks to an optional audio power amplifier to listen to the source selected by the multiroom system. (See page 31 for more information on the multiroom system.)</p> <p><b>10 Video 1 Video Inputs:</b> Connect these jacks to the PLAY/OUT composite or S-Video jacks on a VCR or other video source.</p> <p><b>11 Video 1 Audio Inputs:</b> Connect these jacks to the PLAY/OUT audio jacks on a VCR or other video source.</p> |
|--|---|--|



## REAR PANEL CONNECTIONS (CONT'D)

- 12 Video 1 Video Outputs:** Connect these jacks to the RECORD/INPUT composite or S-Video jack on a VCR.
- 13 Video 1 Audio Outputs:** Connect these jacks to the RECORD/INPUT audio jacks on a VCR.
- 14 Video 2 Video Inputs:** Connect these jacks to the PLAY/OUT composite or S-Video jacks on a TV or other video source.
- 15 Video 2 Audio Inputs:** Connect these jacks to the PLAY/OUT audio jacks on a TV or other video source.
- 16 Video 2 Video Outputs:** Connect these jacks to the RECORD/INPUT composite or S-Video jacks on a TV or other video source.
- 17 Video 2 Audio Outputs:** Connect these jacks to the RECORD/INPUT audio jacks on a TV or other video source.
- 18 Video 3 Video Inputs:** Connect these jacks to the PLAY/OUT composite or S-Video jacks on a cable box or other video source.
- 19 Video 3 Audio Inputs:** Connect these jacks to the PLAY/OUT audio jacks on a cable box or other video source.
- 20 DVD Audio Inputs:** Connect these jacks to the analog audio jacks on a DVD or other video source.
- 21 Digital Audio Outputs:** Connect these jacks to the matching digital input connector on a digital recorder such as a CD-R or MiniDisc recorder.
- 22 Surround Back/Multiroom Speaker Outputs:** These speaker terminals may be used with 7.1-channel systems or to power the output of the multiroom system when the multiroom system and the main room are using the same input. Connect these outputs to the matching + and – terminals on your surround back channel speakers. In conformance with the CEA color-code specification, the brown terminal is the positive (+) terminal that should be connected to the red (+) terminal on the Surround Back Left speaker with older color-coding, while the tan terminal should be connected to the red (+) terminal on the Surround Back Right speaker with older color-coding. Connect the black (–) terminal on the receiver to the matching black negative (–) terminals for each surround back speaker. (See page 14 for more information on speaker polarity and pages 19–20 for information on configuring the DPR 1001 for 7.1 speaker channels. See page 31 for information on powering the multiroom system with the DPR 1001's internal amplifier.)
- 23 Surround Speaker Outputs:** Connect these outputs to the matching + and – terminals on your surround channel speakers. In conformance with the

new CEA color-code specification, the blue terminal is the positive (+) terminal that should be connected to the red (+) terminal on the Surround Left speaker with older color-coding, while the gray terminal should be connected to the red (+) terminal on the Surround Right speaker with the older color-coding. Connect the black (–) terminal on the receiver to the matching black negative (–) terminals for each surround speaker. (See page 14 for more information on speaker polarity.)

**24 Center Speaker Outputs:** Connect these terminals to the matching + and – terminals on your center channel speaker. In conformance with the new CEA color-code specification, the green terminal is the positive (+) terminal that should be connected to the red (+) terminal on speakers with the older color-coding. Connect the black (–) terminal on the receiver to the black negative (–) terminal on your speaker. (See page 14 for more information on speaker polarity.)

**25 Front Speaker Outputs:** Connect these outputs to the matching + or – terminals on your left and right speakers. The white terminal is the positive (+) terminal that should be connected to the red (+) terminal on the Front Left speaker with older color-coding, while the red terminal should be connected to the red (+) terminal on the Front Right speaker with the older color-coding. Connect the black (–) terminal on the receiver to the matching black negative (–) terminals for each front speaker. (See page 14 for more information on speaker polarity.)

**26 AC Accessory Outlets:** These outlets provide power for low-current devices such as a VCR, cable box, CD or DVD player. However, they should *not* be used with high-current devices such as amplifiers. The total power consumption of all devices connected to the accessory outlets should not exceed 100 watts.

The bottom outlet is switched, which means that power is supplied only when the DPR is turned on. Since the power is removed when the DPR is turned off, this outlet should not be used for devices such as VCRs where a constant power source is required for a clock or timer.

The top outlet is unswitched, which means that power is available only when the DPR is plugged in.

**27 AC Power Cord:** Connect the AC plug to an unswitched AC wall outlet.

**28 Preamp Outputs:** These jacks may be connected to an external power amplifier.

**29 LFE/Subwoofer Output:** Connect this jack to the line-level input of a powered subwoofer. This output is filtered, and should be connected to your subwoofer's LFE or other input that bypasses the subwoofer's internal crossover. Consult the owner's manual for

your subwoofer for further information. If an external subwoofer amplifier is used, connect this jack to the subwoofer amplifier input.

**30 Coaxial Digital Audio Inputs:** Connect the coax digital audio output from a DVD player, HDTV receiver, cable box or satellite receiver, the S/P-DIF output of a compatible computer sound card playing MP3 files or streams, an LD player or a CD player to these jacks. The signal may be a Dolby Digital, DTS or compatible MP3 signal, or standard PCM digital source. Do not connect the RF digital output of an LD player directly to these jacks.

**31 Optical Digital Audio Inputs:** Connect the optical digital audio output from a DVD player, HDTV receiver, cable box or satellite receiver, the S/P-DIF output of a compatible computer sound card playing MP3 files or streams, an LD player or a CD player to these jacks. The signal may be a Dolby Digital signal, DTS signal, compatible MP3 signal or standard PCM digital source.

**32 DVD Video Inputs:** Connect these jacks to the composite or S-Video output jacks on a DVD or other video source.

**33 6-Channel Direct Inputs:** When an optional playback device such as a DVD-Audio or SACD player with 5.1 audio capability is in use, connect the player's output jacks here.

**34 8-Channel Direct Inputs:** When an optional playback device such as a DVD-Audio or SACD player with 6.1 or 7.1 audio capability is in use, first connect the Front, Center and Surround Channel outputs to the 6-Channel Direct Input Jacks **33**, then connect the Surround Back channel outputs of the player to these input jacks.

**35 Video Monitor Outputs:** Connect this jack to the composite or S-Video input of a TV monitor or video projector to view the on-screen menus and the output of a composite or S-Video source selected by the DPR 1001.

**36 Video Monitor Component Video Outputs:** Connect these outputs to the component video inputs of a video projector or monitor. When a source connected to one of the two Component Video Inputs **37** **38** is selected the signal will be sent to these jacks.

**37 DVD Component Video Inputs:** Connect the Y/Pr/Pb component video outputs of a DVD player to these jacks.

**38 Video 2 Component Video Inputs:** Connect the Y/Pr/Pb component video outputs of an HDTV set-top converter, satellite receiver or other video source device with component video outputs to these jacks.

REMOTE CONTROL FUNCTIONS

- 1 Power Off Button
- 2 Power On Button
- 3 LCD Information Display
- 4 Input Selectors
- 5 AVR Selector
- 6 Test Button
- 7 DSP Surround Mode Selector
- 8 Logic 7 Mode Select Button
- 9 Direct Button
- 10 Clear Button
- 11 Numeric Keys
- 12 Tuning Mode Button
- 13 Channel Select Button
- 14 Navigation Button
- 15 Digital Select Button
- 16 Set Button
- 17 Transport Play Buttons
- 18 Volume Up/Down Buttons
- 19 Transport Fast-Play/Scan Buttons
- 20 Main Transport Controls
- 21 Track Skip Up/Down Buttons
- 22 Preset Up/Down Button
- 23 Tuning Up/Down Button
- 24 Disc Skip Button
- 25 Program Button
- 26 Light Button
- 27 Multiroom Button
- 28 Macro Buttons
- 29 Sleep Button
- 30 Night Mode Button
- 31 OSD Button
- 32 Tone Control Button
- 33 Mute Button
- 34 AM/FM Button
- 35 Channel Up/Down Selector
- 36 Delay Select Button
- 37 Speaker Select Button
- 38 Memory Button
- 39 Stereo Mode Select Button
- 40 DTS Neo:6 Mode Select Button
- 41 DTS Digital Mode Select Button
- 42 Dolby Surround Mode Select Button
- 43 6/8-Channel Input Select
- 44 SPL Select Button
- 45 EzSet Microphone Sensor
- 46 Lens

NOTES:

- The function names shown here are each button's feature when used with the DPR 1001. Most buttons have additional functions when used with other devices. When a button is pressed, the function name will appear in the bottom line of the LCD Information Display 3.
- The jack on the upper right side of the remote is reserved for future use. Do not remove the plug provided or connect any device to the jack.
- To make it easier to follow the installation instructions that refer to this illustration, a larger copy may be downloaded from the Product Support section at [www.harmankardon.com](http://www.harmankardon.com).

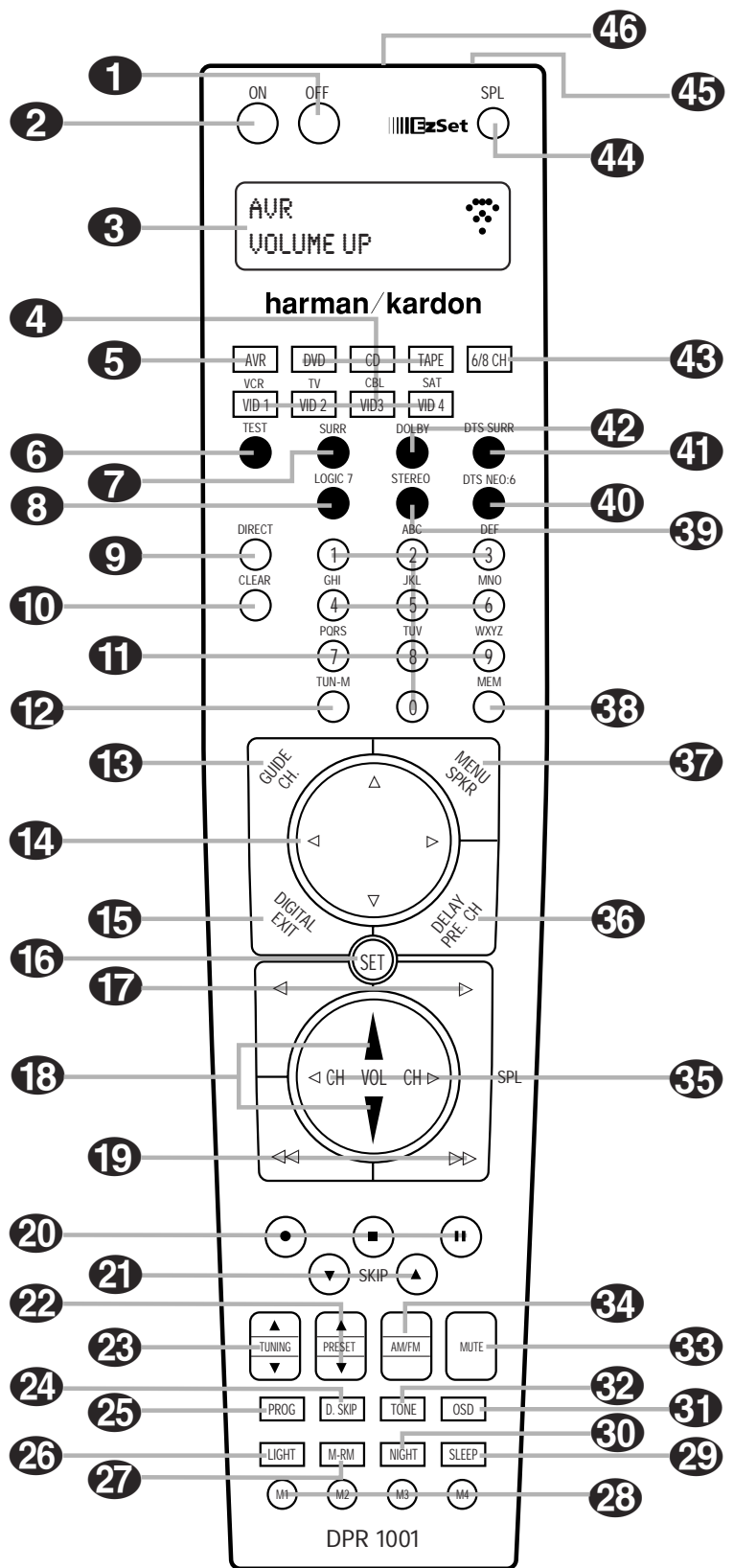

## REMOTE CONTROL FUNCTIONS (CONT'D)

**IMPORTANT NOTE:** The DPR 1001's remote may be programmed to control up to eight devices, including the DPR 1001. Before using the remote, it is important to remember to press the **Input Selector Button 4** that corresponds to the unit you wish to operate. In addition, the DPR 1001's remote is shipped from the factory to operate the DPR 1001 and most Harman Kardon CD or DVD players and cassette decks. The remote is also capable of operating a wide variety of other products using the control codes that are part of the remote. Before using the remote with other products, follow the instructions on pages 32–34 to program the proper codes for the products in your system.

It is also important to remember that many of the buttons on the remote take on different functions, depending on the product selected using the Device Control Selectors. The descriptions shown here primarily detail the functions of the remote when it is used to operate the DPR 1001.

**1 Power Off Button:** Press this button to place the DPR 1001 or a selected device in the Standby mode. Note that this will turn off the main room functions, but if the Multiroom system is activated, it will continue to function.

**2 Power On Button:** Press this button to turn on the power to a device selected by first pressing one of the **Input Selectors 4**.

**3 LCD Information Display:** This two-line screen displays various information depending on the commands that have been entered into the remote.

**4 Input Selectors:** Pressing one of these buttons will perform three actions at the same time. First, if the DPR 1001 is not turned on, this will power up the unit. Next, it will select the source shown on the button as the input to the DPR 1001. Finally, it will change the remote control so that it controls the device selected. After pressing one of these buttons you must press the **AVR Selector Button 5** again to operate the DPR 1001's functions with the remote.

**5 AVR Selector:** Pressing this button will switch the remote so that it will operate the DPR 1001's functions. If the DPR 1001 is in the Standby mode, it will also turn the DPR 1001 on.

**6 Test Button:** Press this button to begin the sequence used to calibrate the DPR 1001's output levels. (See page 23 for more information on calibrating the DPR 1001.)

**7 DSP Surround Mode Selector:** Press this button to select from among the available DSP surround modes. (See page 26 for more information on the Theater, Hall and VMAX modes.)

**8 Logic 7 Selector:** Press this button to select from among the available Logic 7 surround modes. (See page 26 for the available Logic 7 options.)

**9 Direct Button:** Press this button when the tuner is in use to start the sequence for direct entry of a station's frequency. After pressing the button, simply press the proper **Numeric Keys 11** to select a station. (See page 28 for more information on the tuner.)

**10 Clear Button:** When programming the remote or using the EzSet feature, press this button to cancel the current function. When using the remote to enter frequencies for direct tuner access, press this button to clear previous entries.

**11 Numeric Keys:** These buttons serve as a ten-button numeric keypad to enter tuner preset positions. They are also used to select channel numbers when TV, Cable or SAT has been selected on the remote, or to select track numbers on a CD, DVD or LD player, depending on how the remote has been programmed.

**12 Tuning Mode:** Press this button when the tuner is in use to select between automatic tuning and manual tuning. When the button is pressed so that **MANUAL TUNING** appears in the **Lower Display Line B**, pressing the **Tuning Selector 8 23** will move the frequency up or down in single-step increments. When the FM band is in use, pressing this button for manual tuning when a station's signal is weak will change to monaural reception. (See page 28 for more information.)

**13 Channel Select Button:** This button is used to start the process of setting the DPR 1001's output levels to an external source. Once this button is pressed, press the **▲/▼** on the **Navigation Button 14** to select the channel being adjusted, then press the **Set Button 16**, followed by the **▲/▼** on the **Navigation Button 14** again, to change the level setting. (See page 29 for more information.)

**14 Navigation Button:** This single disc-like button is used to navigate through the on-screen configuration menus, to scroll through the options list and to select choices for the various settings such as delay, speakers, surround modes, digital inputs, etc. To use the button, simply press it left, right, up or down in the direction indicated by the **▲▼◀▶** icons printed on the button disc. Depending on the menu being used, pressing the button will either change the video highlight that indicates a specific choice or it will change the option shown in the on-screen or front panel display. The sections in this manual describing the unit's individual features and configuration options contain specific information on how the navigation controls are used.

**15 Digital Select Button:** Press this button to assign one of the digital inputs **30 31 21 23** to a source. (See page 27 for more information on using digital inputs.)

**16 Set Button:** This button is used to enter settings into the DPR 1001's memory. It is also used in the setup procedures for delay time, speaker configuration and channel output level adjustment.

**17 Transport Play Buttons:** These buttons have no direct function on the DPR 1001, but they are used when the remote is programmed for a compatible DVD, CD or tape player. Pressing these buttons will transmit a forward- or reverse-play command, according to the capabilities of the player being controlled. In the factory default setting, these buttons are programmed for Harman Kardon DVD players so that you may control a compatible player without having to switch devices.

**18 Volume Up/Down Buttons:** These controls share the common disc in the lower third of the remote. To raise the volume, press the button marked **▲** by pressing towards the top of the remote. To lower the volume, press the button marked **▼** by pressing towards the bottom of the remote. The **◀▶** buttons on the left and right sides of this disc change channels up or down when the TV, cable box or satellite **Input Selectors 4** have been pressed.

**19 Transport Fast-Play/Scan Buttons:** These buttons have no direct function on the DPR 1001, but they are used when the remote is programmed for a compatible DVD, CD or tape player. Pressing these buttons will transmit a fast-play forward, fast-play reverse, or fast-forward or -reverse scan command, according to the capabilities of the player being controlled. In the factory default setting, these buttons are preprogrammed with the remote codes for Harman Kardon DVD players so that you may control a compatible player without having to switch devices.

**20 Main Transport Controls:** These buttons have no direct function on the DPR 1001, but they are used when the remote is programmed for a compatible DVD, CD or tape player. Pressing these buttons will transmit a stop (■) record (●) or pause (⏸) command, according to the capabilities of the player being controlled. In the factory default setting, these buttons are programmed with the remote codes for Harman Kardon DVD players so that you may control a compatible player without having to switch devices.

**21 Track Skip Up/Down Button:** This button does not have a direct function with the DPR 1001, but when used with a compatibly programmed CD or DVD changer it will change the track or chapter currently being played. In the factory default setting, this button is programmed with the remote codes for Harman Kardon DVD players so that you may control a compatible player without having to switch devices.

**22 Preset Up/Down Button:** When the tuner is in use, press this button to scroll through the stations programmed into the DPR 1001's memory.

## REMOTE CONTROL FUNCTIONS (CONT'D)

**23 Tuning Up/Down:** When the tuner is in use, this button will tune up or down through the selected frequency band. If the **Tuning Mode Button 12 7** has been pressed so that **AUTO** appears in the **Lower Display Line B**, pressing either button will cause the tuner to seek the next station with acceptable signal strength for quality reception. When **MANUAL** appears in the **Lower Display Line B**, pressing this button will tune stations in single-step increments. (See page 28 for more information.)

**24 Disc Skip Button:** This button has no direct function for the DPR 1001 but may be used to change the disc in a CD or DVD changer when the remote is programmed for that type of device. (See page 35 for more information.)

**25 Program Button:** This button is used to begin the process of programming the remote. Press and hold this button for three seconds to place the remote in the programming mode. Once the red LED under the **Set Button 16** lights, release the button. You may then select from the desired option. (See pages 32–41 for more information on configuring the remote.)

**26 Light Button:** Press this button to activate the remote's backlight for ease of use in darkened rooms.

**27 Multiroom:** Press this button to activate the multiroom system or to begin the process of changing the input or volume level for the second zone. (See page 31 for more information on the multiroom system.)

**28 Macro Buttons:** Press these buttons to store or recall a "Macro", which is a preprogrammed sequence of commands stored in the remote. (See page 35 for more information on macros.)

**29 Sleep Button:** Press this button to place the unit in the Sleep mode. After the time shown in the display, the DPR 1001 will automatically go into the Standby mode. Each press of the button changes the time until turn-off in the following order:

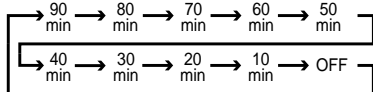

**30 Night Mode:** Press this button to activate the Night mode. This mode is available in specially encoded Dolby Digital sources, and it preserves dialogue (center channel) intelligibility at low volume levels.

**31 OSD Button:** Press this button to activate the On-Screen Display (OSD) system used to set up or adjust the DPR 1001's parameters.

**32 Tone Control Button:** This button controls whether or not the Bass and Treble controls are active, and, if so, the degree to which they are used. The first press of this button tells the current status of the tone controls: if **TONE OUT** is displayed in the Lower

Display Line **B**, the tone controls are not in the signal path, and the DPR's output is "flat." If **TONE IN** is displayed, the controls are active. To switch the tone controls in or out, press the **▲/▼ Navigation Button 14** so that the desired setting appears. To change the actual bass or treble settings, first make certain that **TONE IN** has been activated, and then press the button again so that either **BASS MODE** or **TREBLE MODE** appears. Within five seconds, press the **▲/▼ Navigation Button 14** to enter the desired setting.

**33 Mute:** Press this button to momentarily silence the DPR 1001 or TV set being controlled, depending on which device has been selected.

**34 AM/FM Tuner Select:** Press this button to select the DPR 1001's tuner as the listening choice. Pressing this button when the tuner is already in use will select between the AM and FM bands.

**35 Channel Up/Down Selector:** These buttons have no function when the DPR is being controlled, but when programmed for use with a VCR, TV, cable box, satellite receiver or other similar product they will change the channel up or down. See pages 32–34 for more information on programming the remote.

**36 Delay/Select:** Press this button to begin the process for setting the delay times used by the DPR 1001 when processing surround sound. After pressing this button, the delay times are entered by pressing the **Set Button 16** and then the **▲/▼ Navigation Button 14** to change the setting. Press the **Set Button 16** again to complete the process. (See page 21 for more information on setting delay times.)

**37 Speaker Select:** Press this button to begin the process of configuring the DPR 1001's bass management system. Then press the **▲/▼ Navigation Button 14** to select the channel you wish to set up. Press the **Set Button 16** and then select the speaker type. When all adjustments have been completed, press the **Set Button 16** twice to exit the settings and return to normal operation. (See page 19 for more information on speaker setup.)

**38 Memory Button:** Press this button to enter a radio station into the DPR 1001's preset memory. Once **PRESET MEMORY** flashes in the **Lower Display Line B**, you have five seconds to enter a preset memory location using the **Numeric Keys 11**. (See page 28 for more information.)

**39 Stereo Mode Selector:** Press this button to select a stereo listening mode. The first press of the button places the DPR 1001 in a true, two-channel, left/right Stereo mode with no surround processing. The next press selects either five-channel Stereo or

seven-channel Stereo, depending on the speaker configuration.

**40 DTS Neo:6 Mode Selector:** Press this button to select a DTS Neo:6 mode. (See page 26 for the available DTS Neo: 6 options.)

**41 DTS Digital Mode Selector:** When a DTS-encoded digital source is playing, each press of this button will scroll through the available DTS modes. The specific choice of modes will vary according to the type of encoding on the disc and your system's speaker configuration. When a DTS source is not in use, this button has no function. (See page 26 for the available DTS digital options.)

**42 Dolby Surround Mode Selector:** This button is used to select from the available Dolby Surround modes. Each press of this button will select one of the Dolby Pro Logic II modes or Dolby 3 Stereo. When a Dolby Digital-encoded source is in use, the Dolby Digital mode may also be selected. (See page 26 for the available Dolby surround mode options.)

**43 6-Channel/8-Channel Input Select:** Press this button to select the device connected to the **6-Channel Direct Inputs 33** or the **8-Channel Direct Inputs 34**. (See page 29 for more information.)

**44 SPL Select:** This button activates the DPR 1001's EzSet function to quickly and accurately calibrate the DPR 1001's output levels. When the button is pressed you will then need to select between automatic EzSet operation or using the remote as a manual SPL meter by pressing the **▲/▼ Navigation Button 14** until your choice appears in the remote's LCD display. Press the **Set Button 16** to enter the setting, and then follow the instructions as displayed in the LCD display. For complete information, see page 22.

**45 EzSet Microphone Sensor:** The microphone sensor that is used by the EzSet system is behind the three slots at the top of the remote control. When using EzSet to calibrate the DPR 1001 be certain that the slots are not covered. (See page 22 for more information on using EzSet.)

**46 Lens:** The infrared emitters behind the plastic lens at the top of the remote communicate the remote codes to the DPR 1001. Be certain that the lens is not covered when using the remote, and point the lens toward the DPR for best results. In learning mode, the remote receives IR codes to be learned through a sensor behind the lens.

**NOTE:** DO NOT remove the rubber plug that is supplied to cover the jack on the upper right side of the remote. The jack is not active and is reserved for future use.

## BASIC TROUBLESHOOTING/PROCESSOR RESET

SYMPTOM	CAUSE	SOLUTION
Unit does not function when Main Power Switch is pushed.	<ul style="list-style-type: none"> <li>No AC Power</li> </ul>	<ul style="list-style-type: none"> <li>Make certain AC power cord is plugged into a live outlet.</li> <li>Check to see whether outlet is switch-controlled.</li> </ul>
Display lights, but there is no sound or picture.	<ul style="list-style-type: none"> <li>Intermittent input connections</li> <li>Mute is on</li> <li>Volume control is down</li> </ul>	<ul style="list-style-type: none"> <li>Make certain that all input and speaker connections are secure.</li> <li>Press Mute button.</li> <li>Turn up volume control.</li> </ul>
Unit turns on, but front panel display does not light up.	<ul style="list-style-type: none"> <li>Display brightness is turned off</li> </ul>	<ul style="list-style-type: none"> <li>Follow the instructions in the Display Brightness section on page 30 so that the display is set to <b>VFD FULL</b>.</li> </ul>
No sound from any speaker; light around power switch is red.	<ul style="list-style-type: none"> <li>Amplifier is in protection mode due to possible short</li> <li>Amplifier is in protection mode due to internal problems</li> </ul>	<ul style="list-style-type: none"> <li>Check speaker wire connections for shorts at receiver and speaker ends.</li> <li>Contact your local Harman Kardon service center.</li> </ul>
No sound from surround or center speakers.	<ul style="list-style-type: none"> <li>Incorrect surround mode</li> <li>Input is monaural</li> <li>Incorrect configuration</li> </ul>	<ul style="list-style-type: none"> <li>Select a mode other than Stereo.</li> <li>There is no surround information from mono sources.</li> <li>Check speaker configuration. (See pages 19–21.)</li> </ul>
Receiver does not play correct soundtrack from DTS or Dolby Digital DVDs.	<ul style="list-style-type: none"> <li>DVD disc or player menus set incorrectly</li> </ul>	<ul style="list-style-type: none"> <li>Check the setup menu in your DVD player or the "Audio" menu in the disc being played to make certain that the player is set for the desired output signal.</li> </ul>
Unit does not respond to remote commands.	<ul style="list-style-type: none"> <li>Weak batteries in remote</li> <li>Wrong device selected</li> <li>Remote sensor is obscured</li> </ul>	<ul style="list-style-type: none"> <li>Change remote batteries.</li> <li>Press the AVR selector.</li> <li>Make certain front panel sensor is visible to remote, or connect remote sensor.</li> </ul>
Intermittent buzzing in tuner.	<ul style="list-style-type: none"> <li>Local interference</li> </ul>	<ul style="list-style-type: none"> <li>Move unit or antenna away from computers, fluorescent lights, motors or other electrical appliances.</li> </ul>
Speaker Channel Input indicators flash and digital audio stops.	<ul style="list-style-type: none"> <li>Digital audio feed paused</li> </ul>	<ul style="list-style-type: none"> <li>Resume play for DVD.</li> <li>Check that Digital Input is selected.</li> </ul>

## Processor Reset

In the rare case in which the unit's operation or the displays seem abnormal, the cause may involve the erratic operation of the system's memory or microprocessor.

To correct this problem, first unplug the unit from the AC wall outlet and wait at least three minutes. After the pause, reconnect the AC power cord and check the unit's operation. If the system still malfunctions, a system reset may clear the problem.

To totally reset the DPR 1001's processor and clear all setting and configuration data, including all tuner presets, output level settings, delay times, surround mode choices, speaker configuration and crossover data, follow these steps:

- Turn the unit completely off by pressing the **Main Power Switch 19** so that it is in the OFF position.
- Press and hold the **Tuning Mode Selector 7** and the **Tuning ▼ Button 8**, and at the same time press the **Main Power Switch 19** in so that it is in the ON position.
- When the **Upper Display Line F** reads **RESET**, release the **Tuning Mode Selector 7** and **Tuning ▼ Button 8**.
- After a few seconds the unit will go into a display test mode that will illuminate all segments of the **Main Information Display 16**.
- Press the **Standby/On Button 2** to return the DPR to normal operation.

When the reset is complete you may return to normal operation, but remember that all system configuration settings and tuner presets will have to be reentered.

**NOTE:** Resetting the processor will erase any configuration settings you have made for speakers, output levels, surround modes and digital input assignments,

as well as the tuner presets. After a reset, the unit will be returned to the factory presets, and all settings for these items must be reentered.

If the system is still operating incorrectly, there may have been an electronic discharge or severe AC line interference that has corrupted the memory or microprocessor.

If these steps do not solve the problem, consult an authorized Harman Kardon service center.

DPR1001 EXPLODED VIEW

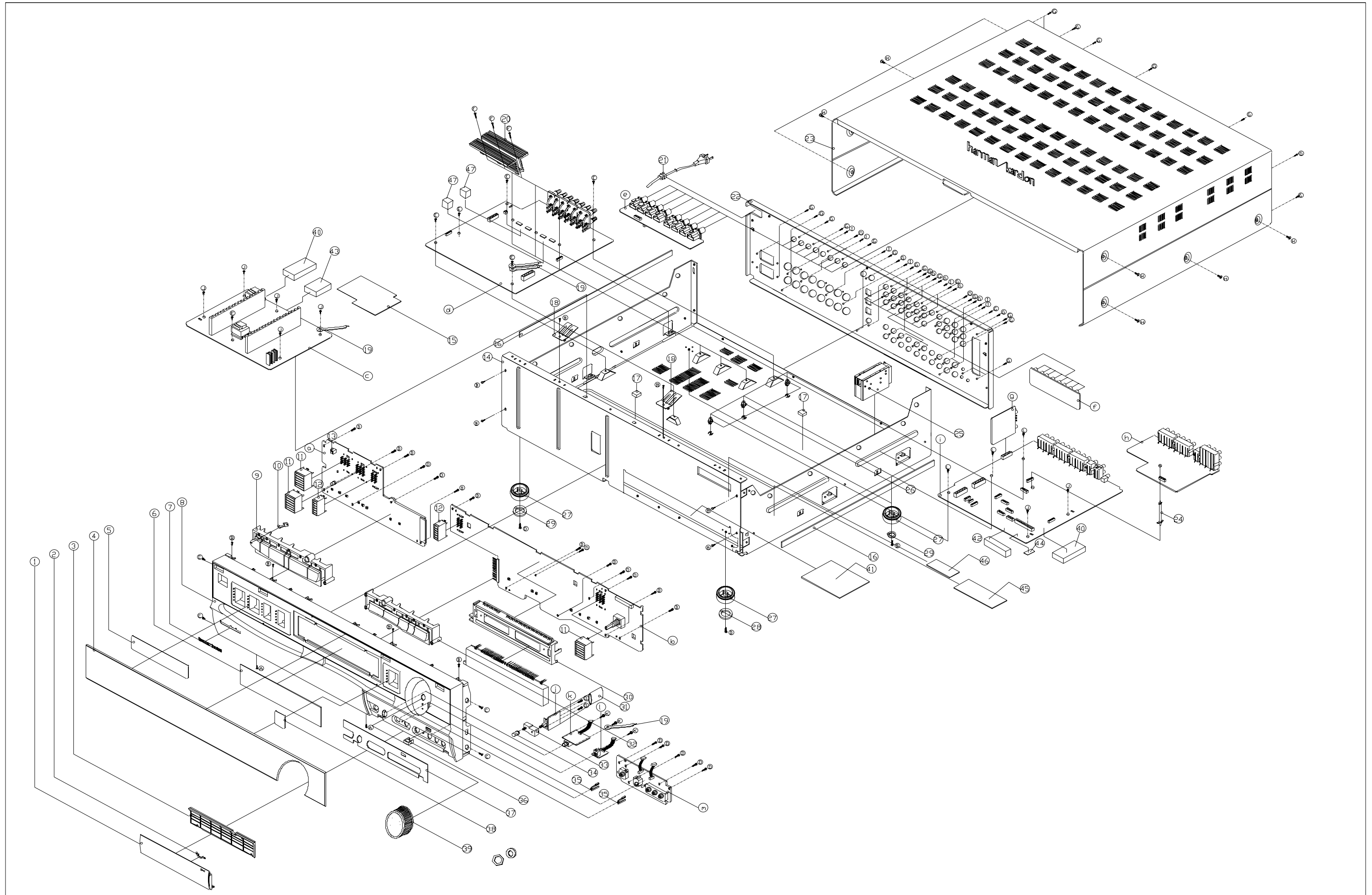

NO	PARTS NAME	CODE NO	Q,TY	REMARK
1	DOOR-CAP	MJAF - 04070 - 012	1	ABS-728
2	BRACKET-MAGNET	MPAC - 17490 - 004	1	SECC T0.8
3	DOOR-BASE	MJAF - 09670 - 013	1	ABS-720
4	WINDOW-FL	MAAF - 04090 - 012	1	PMMA 60N<HI-8>
5	SHEET-LED<A>	MAAF - 18710 - 004	1	PE SHEET
6	FILTER-FL	MAAF - 18700 - 014	1	PVC
7	BADGE-H/K	MLAG - 13850 - 034	1	AL<SILVER>
8	PANEL-FRONT	MJAF - 06880 - 011	1	HFA-403
9	KNOB-FUNCTION<A>	MJAF - 09690 - 013	1	ABS-720
10	LENS-POWER	MJAF - 18670 - 014	1	PMMA
11	GUIDE-LED<A>	MJAF - 18630 - 004	3	ABS
12	GUIDE-LED<B>	MJAF - 18640 - 004	2	ABS
13	GUIDE-REMOTE	MJAF - 18620 - 004	1	ABS
14	CHASSIS-BOTTOM	MPAC - 05320 - 002	1	SECC T 1.0
15	INSULATION-SHEET	MAAF - 18930 - 004	1	PVC T0.3
16	CUSHION-A	MRAG - 13050 - 004	2	FELT
17	CUSHION-SUPPORT	MRAG - 14710 - 004	2	EVA
18	SPRING-PLATE	MPAC - 17470 - 004	2	PB T0.2
19	CLAMP-WIRE	MPAC - 17730 - 004	1	*****
20	HEATSINK-MAIN	MEAC - 05361 - 003	1	AL6063 T5
21	CORD-BUSH	MJAG - 00280 - 012	1	*****
22	CHASSIS-BACK	MPAC - 05280 - 012	1	SECC T 0.8
23	CHASSIS-TOP	MPAC - 05330 - 012	1	VCM T0.8
24	SUPPORT	MJAG - 14740 - 004	1	*****
25	TUNER-PACK	***** - ***** - ***	1	*****
26	SUPPORT-PCB	MJAF - 18680 - 004	3	ABS
27	FOOT	MJAF - 09680 - 013	4	ABS
28	CUSHION-FOOT<FRONT>	MRAG - 14551 - 004	2	POLYURETHAN T3
29	CUSHION-FOOT<REAR>	MRAG - 14552 - 004	2	POLYURETHAN T3
30	GUIDE-FL	MJAF - 04080 - 002	1	ABS
31	INSULATE-TUBE	MXAG - 14730 - 004	1	POLYOLEFIN T4.0
32	KNOB-FUNCTION<B>	MJAF - 09700 - 013	1	ABS-720
33	JOINT-STANDBY	MJAF - 18650 - 004	1	ABS
34	KNOB-SPEAKER	MJAF - 16060 - 014	1	ABS
35	LENS-OPTICAL	MAAF - 18660 - 014	2	PMMA
36	MAGNET	AXAG - 14700 - 004	1	*****
37	SHEET-DOOR	MAAF - 18750 - 014	1	PVC T 0.25
38	SHEET-LED<B>	MAAF - 18720 - 004	1	PE
39	ASS'Y-VOLUME	AJAF - 09730 - 013	1	ABS+AL+RUBBER
40	CUSHION SMPS	MRAG - 14760 - 004	2	EVA
41	SHEET-EMI	MPAC - 17690 - 004	1	
42	CUSHION <A>	MRAG - 14780 - 004	1	EVA
43	CUSHION <B>	MRAG - 14790 - 004	1	EVA
44	CUSHION FELT	MRAG - 14770 - 004	1	FELT
45	SHEET-EMI-A	MPAC - 17710 - 004	1	
46	SHEET-EMI-B	MPAC - 17720 - 004	1	
47	CUSHION REMOTE	MRAG - 13840 - 004	2	
48	CABLE TIE L80	MJAG - 04540 - 004	12	
A	SCREW-TAPPING	XSTB - 30080 - ZB4	2	AK10
B	SCREW-TAPPING	XSTB - 30080 - ZY4	14	AK10
C	SCREW-TAPPING	XSTF - 30080 - ZY4	4	AK10
D	SCREW-TAPPING	XSTB - 30100 - ZY4	22	AK10
E	SCREW-TAPPING	XSTS - 30080 - ZY4	6	AK10
F	SCREW-TAPPING	MMTc - 15650 - 004	3	AK10
G	SCREW-TAPPING	XSTB - 30100 - ZB4	32	AK10
H	SCREW-TAPPING	MMAC - 16403 - CR4	8	AK10
I	SCREW-T/P-TOOTH	MMAC - 16400 - 004	10	AK10
J	SCREW-TAPPING	MMTc - 00751 - 003	7	AK10
K	SCREW-TAPPING	MMTc - 00752 - 003	3	AK10
L	SCREW-TAPPING	MMTc - 00754 - 003	3	AK10
a	FRONT P.C.BOARD-1	*****	1	***
b	FRONT-P.C.BOARD-2	*****	1	***
c	SMPS P.C.BOARD	*****	1	***
d	PWM-DSP P.C.BOARD	*****	1	***
e	PRE-OUT P.C.BOARD	*****	1	***
f	PRE-INPUT P.C.BOARD	*****	1	***
g	DIGITAL INPUT P.C.BOARD	*****	1	***
h	VIDEO P.C.BOARD	*****	1	***
i	MAIN P.C.BOARD	*****	1	***
j	POWER SWITCH P.C.BOARD	*****	1	***
k	PHONE JACK P.C.BOARD	*****	1	***
l	OPTICAL3 P.C.BOARD	*****	1	***
m	FRONT VIDEO P.C.BOARD	*****		





# DDX Technology

- Traditional Amplifier Technology
  - Class A/B Designs
  - Analog
  - Low Efficiency
- High Efficiency Designs Emerged
  - Analog Class D Designs
  - Class G/H: Vary PS with Class A/B
- Development Goal
  - High Efficiency + Digital = DDX



# DDX The New Standard

- Patented Amplifier Design
- All-Digital
  - Direct Interface to Digital Audio
  - IC Integration
- High Efficiency
  - 3 Times Higher Efficiency
  - Reduced Heat = Smaller Size/Package
  - Power Supply Savings

# DDX Digital Design

## Analog Amplifier

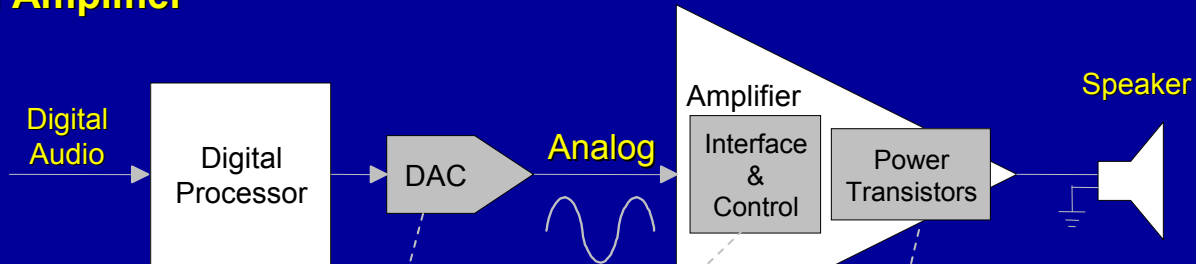

DAC = Digital to Analog Converter

Combine DAC  
and Control

Utilize High  
Efficiency Design

## DDX Amplifier



DDX Eliminates DAC and Analog Signals

# DDX Functional Diagram

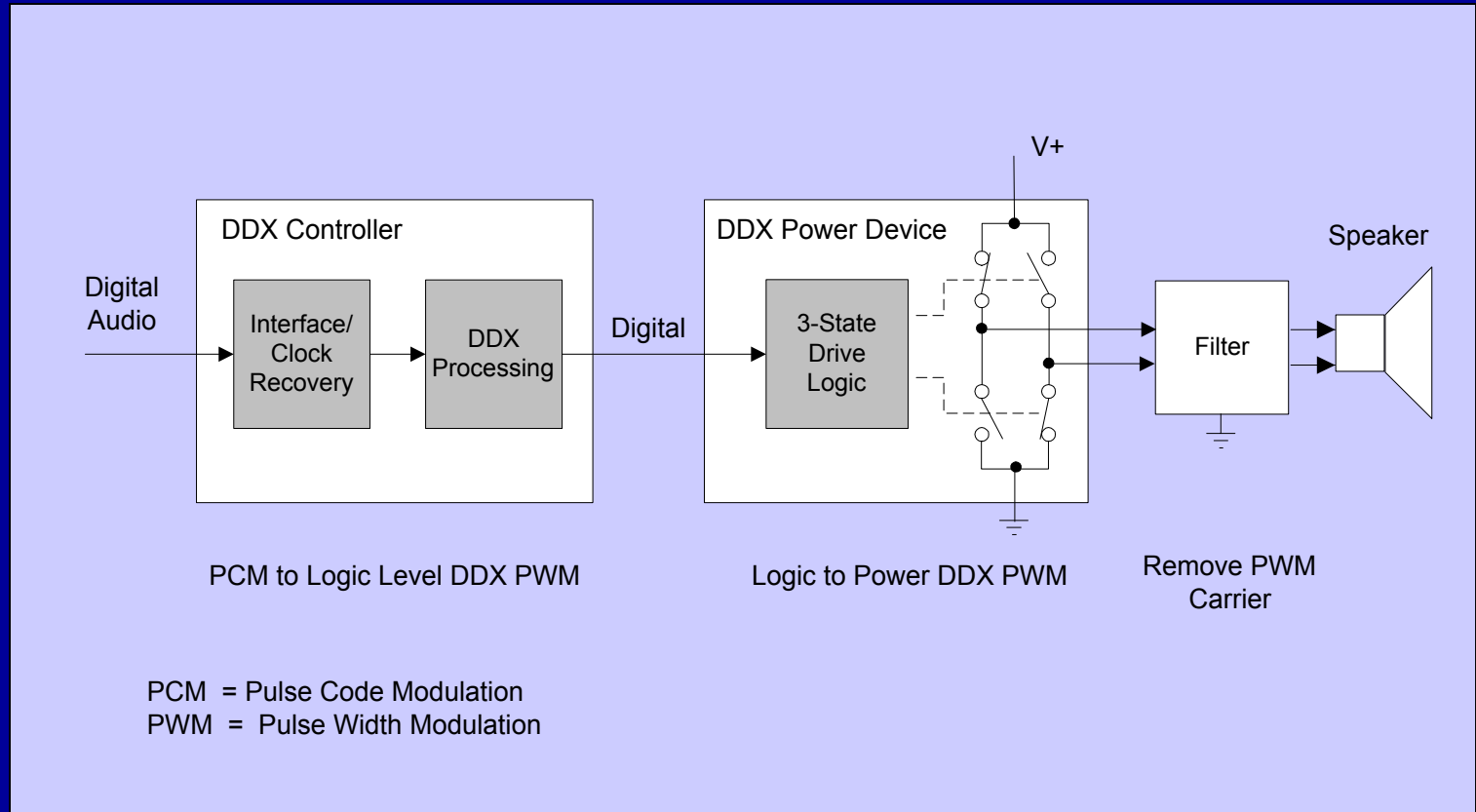

*DDX Digital Control Of 3-State Power Stage*

# DDX Drive States

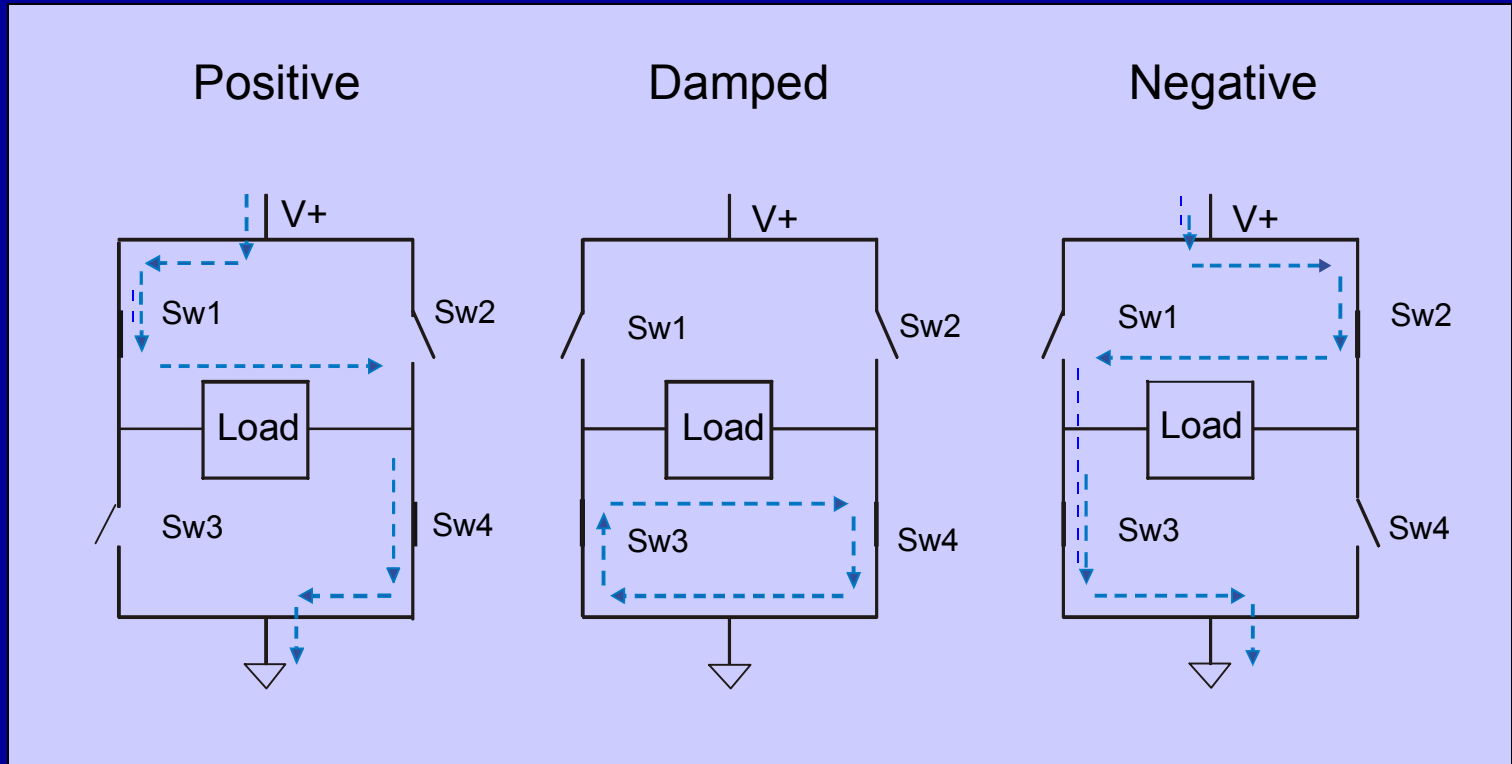

*DDX Damped State Increase Efficiency and Lowers EMI Compared to Binary Designs*

# DDX 3-State Modulation

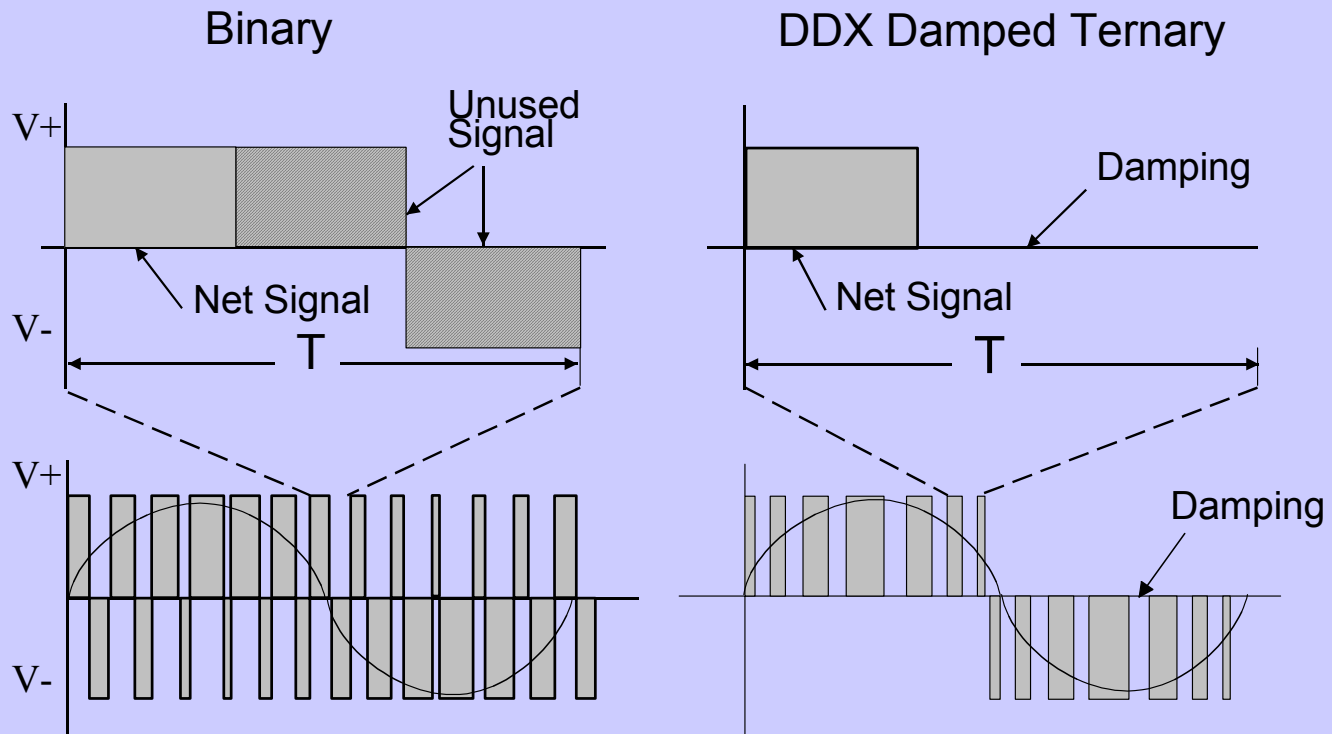

*DDX Only Outputs a Signal When Required*

# DDX Efficiency Advantage

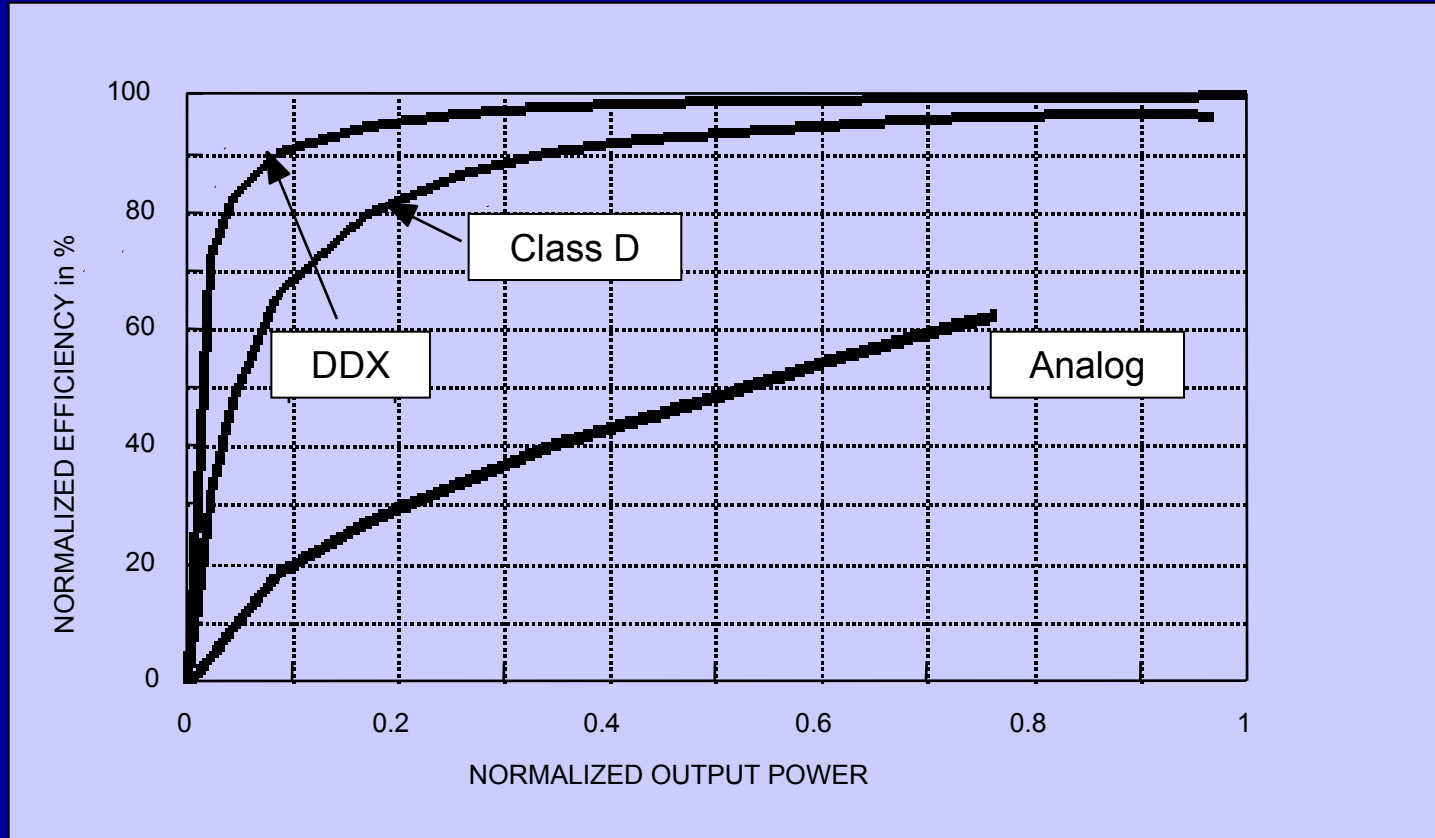

*DDX Modulation Increases Class D Efficiency*

# DDX EMI/RFI Advantage

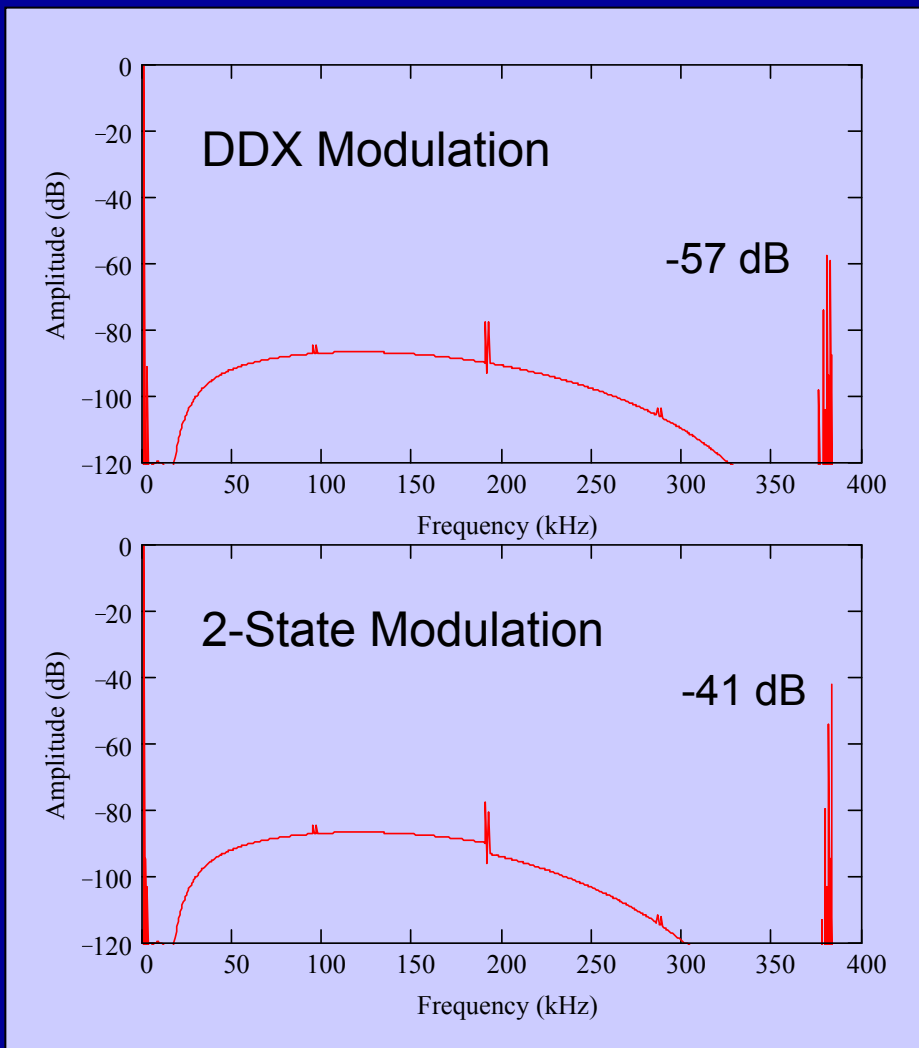

## Theoretical Performance

- 0 dB, 1.0 kHz Input
- 30 kHz 2<sup>nd</sup> Order LPF

***DDX is 16 dB Lower  
Carrier Than  
2-State Modulation!***



# DDX Low Cost Integration

## Digital IC Process Improvements

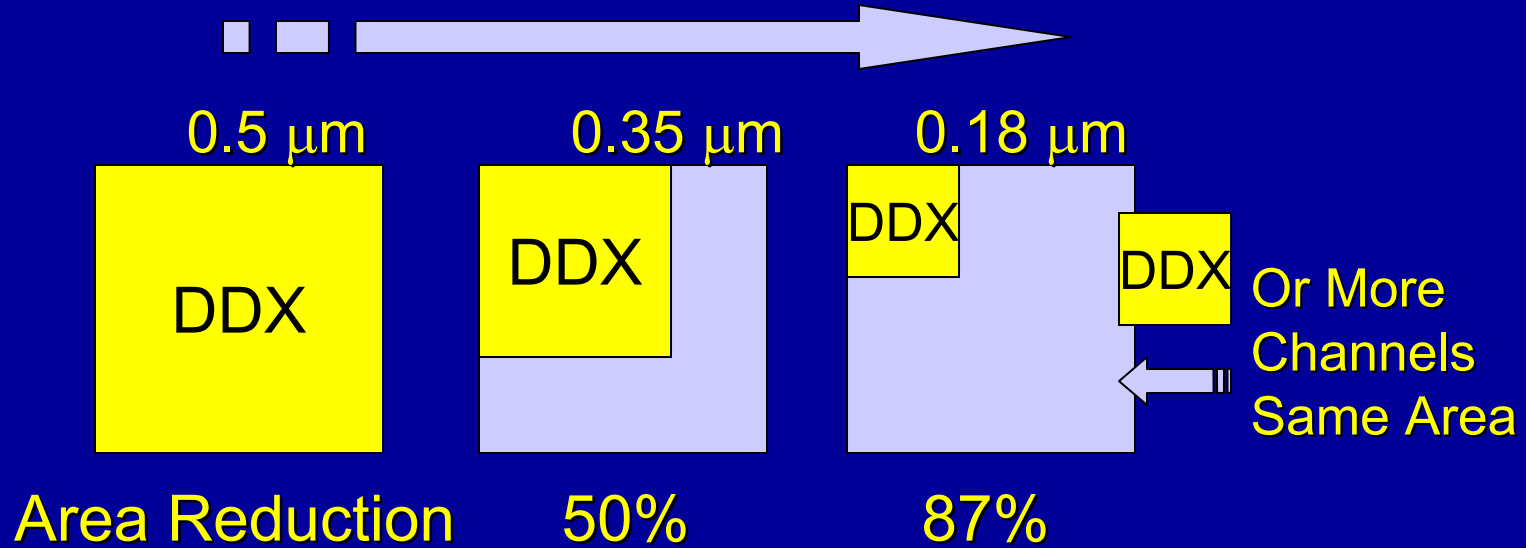

*DDX Area Reduces with IC Processes  
Analog Designs DO NOT Follow Same Trend*

# DDX-2100 Power IC

*50W Stereo DDX Power IC  
Samples Q4'01*

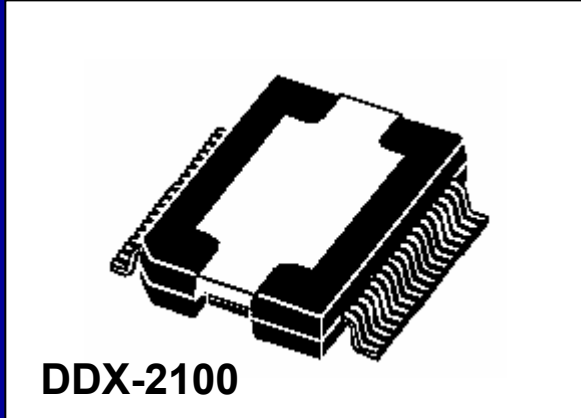

**PowerSO36**

Operation (with DDX-2000)

- Single Supply (+10V to +36V)
- Output Power
  - 2x50+ W into 8Ω
  - 1x100+ W into 4Ω
- Efficiency 88%
- Short Circuit Protection
- Thermal Protection
- Powerdown Mode

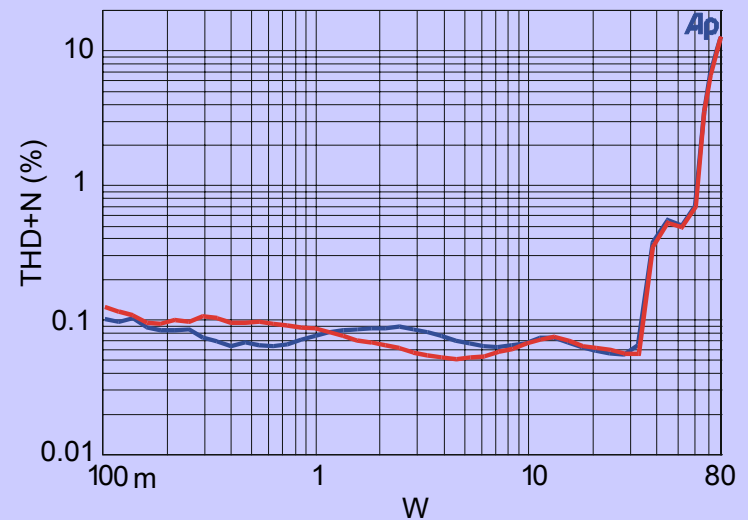

# DDX-4100 Controller

*Multi-Channel Design  
Providing Complete  
End-to-End Digital Solution*



**TQFP 44, 3.3V CMOS Device**

## FEATURES

### Interface/Control

- 4 Channel Serial, ACLink, S/PDIF Inputs
  - 32kHz - 96kHz
- 4.1 Channel DDX Outputs
- 6 Channel Serial Output
- I2C Control

### Enhanced Digital Audio Functions

- Volume Control
- Bass/Treble
- Parametric EQ
- Bass Management
- Automatic Mute
- Anti Clipping

# DDX-4100 Processing

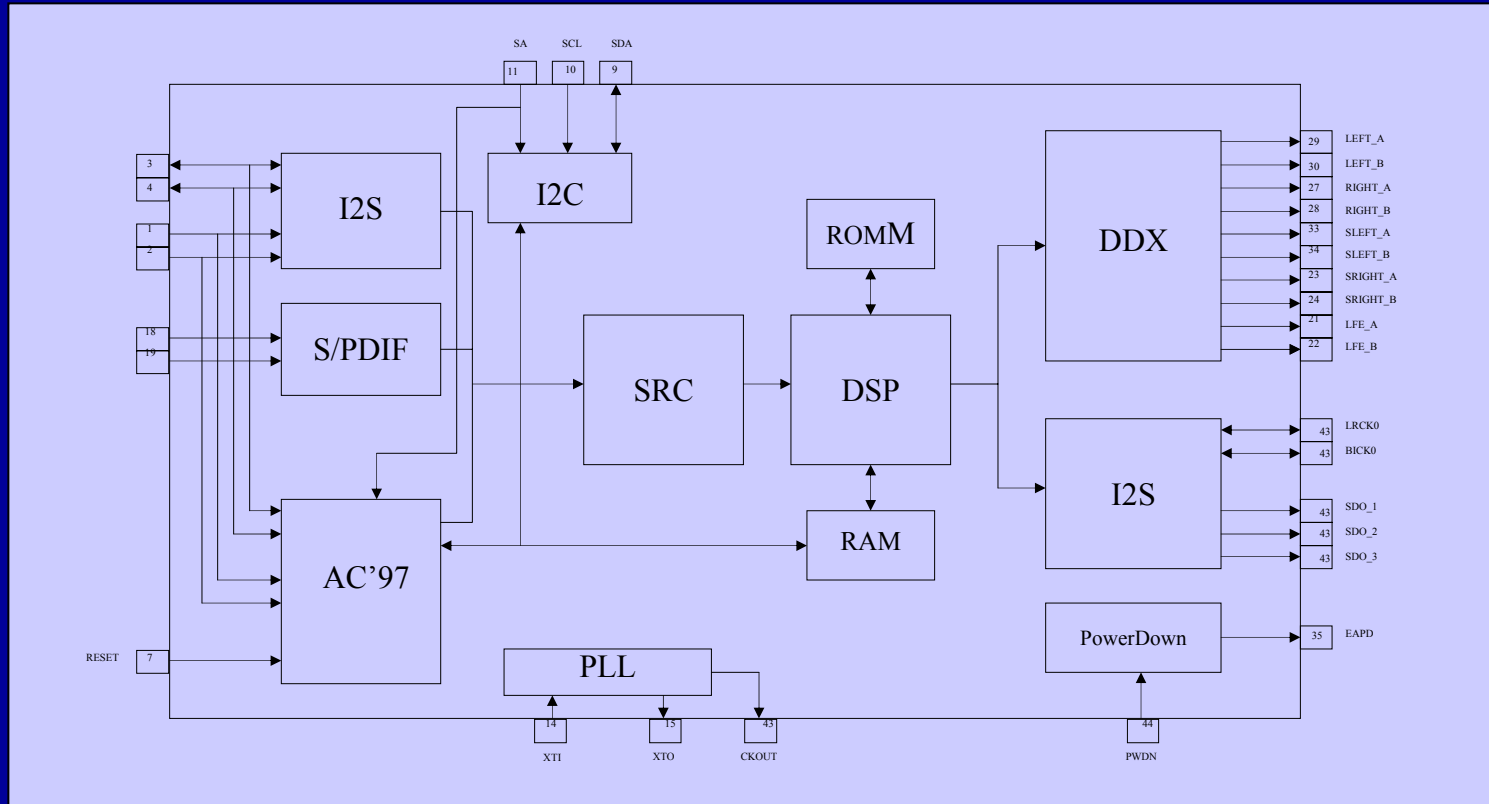

- Multiple Digital Interface Standards
- SRC Conversion to 48 kHz for DSP Operations
- 20 Bit DSP Performs Preamplifier and EQ Functions
- 5 Channel DDX + Serial Outputs

# DDX-2100 Power Output - Stereo

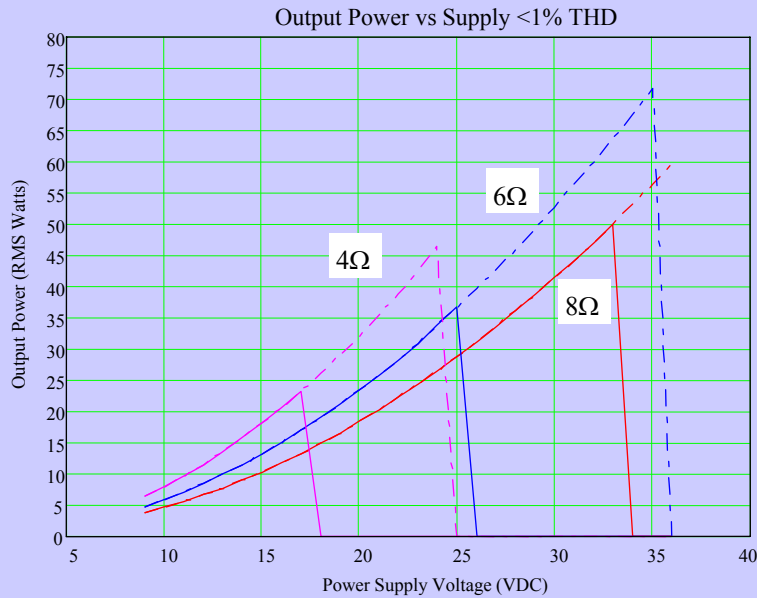

- 8 Ohm Load, Iout = 3.5A
- 8 Ohm Load, Iout = 5A
- 6 Ohm Load, Iout = 3.5A
- 6 Ohm Load, Iout = 5A
- 4 Ohm Load, Iout = 3.5A
- 4 Ohm Load, Iout = 5A

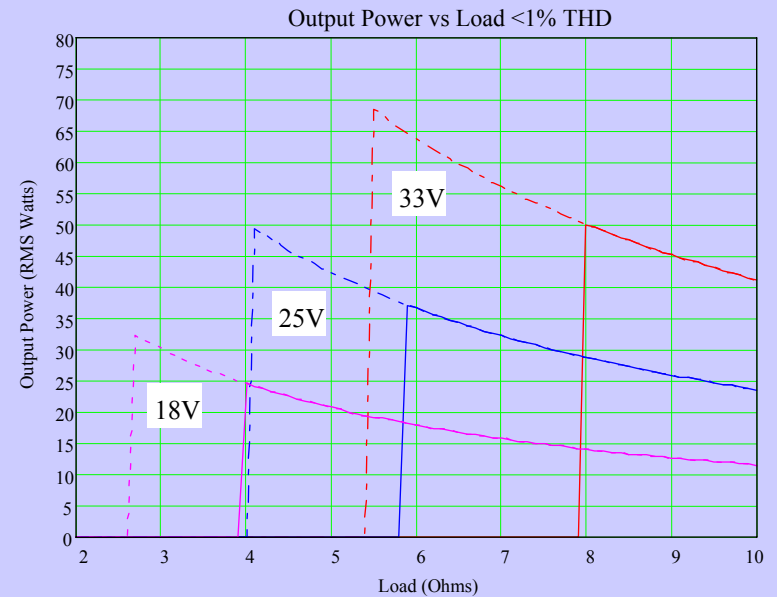

- Vdd = 33V, Iout = 3.5A
- Vdd = 33V, Iout = 5A
- Vdd = 25V, Iout = 3.5A
- Vdd = 25V, Iout = 5A
- Vdd = 18V, Iout = 3.5A
- Vdd = 18V, Iout = 5A

*Output Power of 2x50 Watts at 33V, 8 Ω (Minimum)  
Power Reaches over 2x75 Watts (36V, Typical) at 10% THD*

# DDX-2100 Power Output - Mono

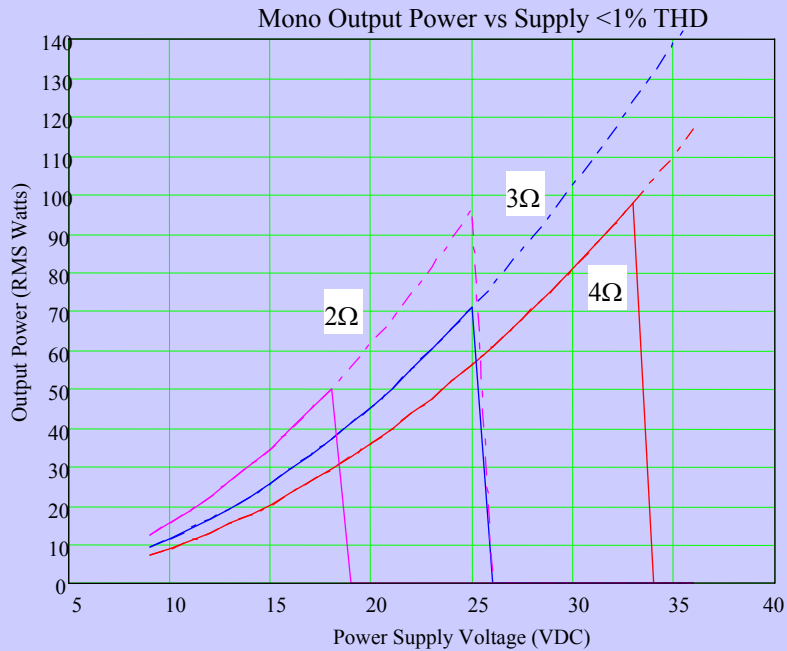

- 4 Ohm Load, Iout = 7A
- - 4 Ohm Load, Iout = 10A
- 3 Ohm Load, Iout = 7A
- - 3 Ohm Load, Iout = 10A
- 2 Ohm Load, Iout = 7A
- - 2 Ohm Load, Iout = 10A

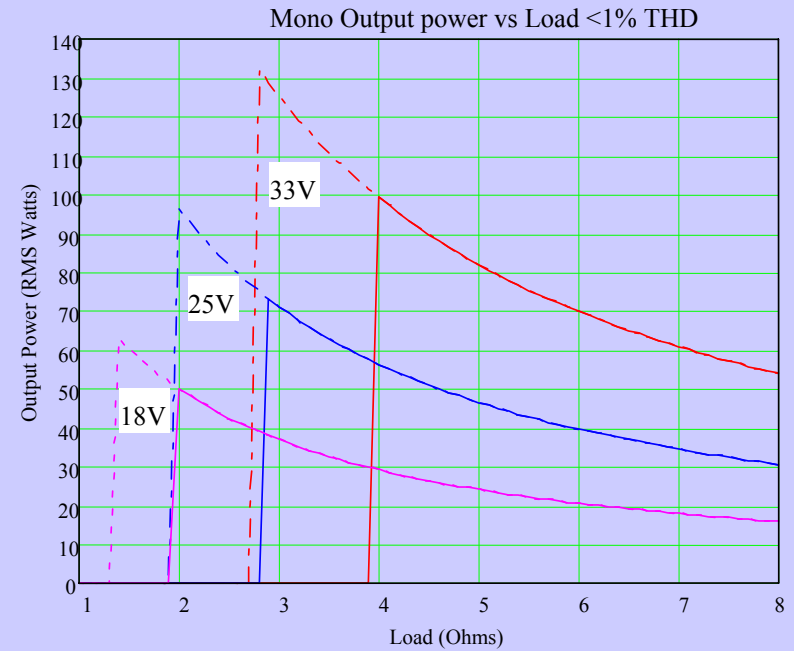

- Vdd = 33V, Iout = 7A
- - Vdd = 33V, Iout = 10A
- Vdd = 25V, Iout = 7A
- - Vdd = 25V, Iout = 10A
- Vdd = 18V, Iout = 7A
- - Vdd = 18V, Iout = 10A

*Mono Mode Parallels Outputs to Double Current To Load  
Up to 150 Watts Output (36V, 10%) and 100 Watts (Min) into 4 Ω*

SMPS  
POWER  
SUPPLY

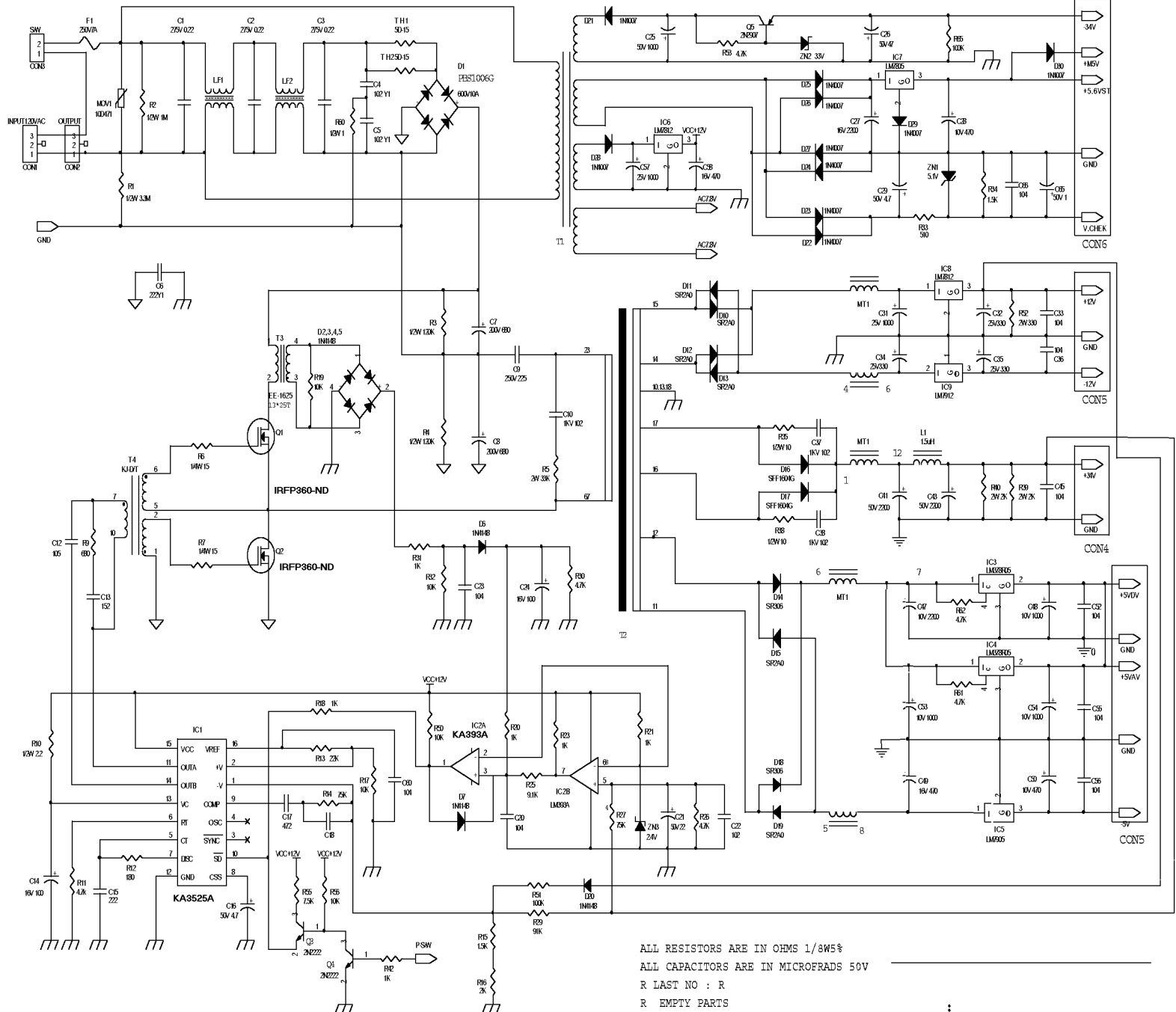

ALL RESISTORS ARE IN OHMS 1/8W5%  
 ALL CAPACITORS ARE IN MICROFRADS 50V  
 R LAST NO : R  
 R EMPTY PARTS  
 C LAST NO : C  
 C SEPARATION PARTS

MODEL NO	KJP-3011		<b>P A R T S   L I S T</b>				DATA	2003.04.23
COMMODITY							PAGE	5
PART	CIRCUITS						MANUFACTURE	REMARK
NO	DE NO	DESCRIPTION	SPECIFICATION	QTY	LOCATION NO			
1		PWM IC	KA3525A (DIP-16)	1	IC1	F/C		
2		COMP-IC	LM393 (DIP-8)	1	IC2	HITACHI, F/C		
3		REG-IC	LM378R05 (TO-220F)	2	IC3.4	F/C		
4		REG-IC	LM7805 (TO-220)	1	IC7	F/C		
5		REG-IC	LM7905 (TO-220)	1	IC5	F/C		
6		REG-IC	LM7812 (TO-220)	2	IC6. IC8	F/C		
7		REG-IC	LM7912 (TO-220)	1	IC9	F/C		
8		MOS-FET	SSH25N40, IRFP360 (TO-3P)	2	Q1.Q2	F/C. IR		
9		TRANSISTOR	KTA1273 (TO-92)	1	Q5	WOOSUK, F/C		
10		TRANSISTOR	KTN2222A (TO-92)	2	Q3.Q4	WOOSUK, F/C		
11		BRG-DIODE	PBS-1006G	1	D1	DAEBO, SHINDENGEN		
12		S/W DIODE	1N4148	7	D2.3.4.5.6.7.20	T/S, SUNG HO		
13		DIODE	1N4007	10	D21.22.23.24.25.26.27.28.29.30	T/S, SUNG HO		
14		SCHOTTKY-DIODE	SR-2A0	6	D10.11.12.13.15.19	T/S, SUNG HO		
15		SCHOTTKY-DIODE	SR306	2	D18.14	T/S, SUNG HO		
16		FR-DIODE	SFF1604G	2	D16.D17	T/S, SUNG HO		
17		UF-DIODE	UF4004	4	D10.11.12.18	T/S, SUNG HO		
18		ZN-DIODE	1N4370 (0.5W 2.4V)	1	ZN3	T/S, SUNG HO		
19		ZN-DIODE	1N4750 (1W 27V)	1	ZN2	T/S, SUNG HO		
20		ZN-DIODE	1N5231 (0.5W 5.1V)	1	ZN1	T/S, SUNG HO		
21		AL-CAPACITOR	200V 680uF (25φX 50) 85°C	2	C7.8	SAMYOUNG, SAMWHA		
22		AL-CAPACITOR	50V 2200uF (16φX 36) 105°C	2	C41.43.	SAMYOUNG, SAMWHA		
23		AL-CAPACITOR	50V 1000uF (12.5φX 25) 85°C	1	C25	SAMYOUNG, SAMWHA		
24		AL-CAPACITOR	50V 47uF (6.3φX 11) 85°C	1	C26	SAMYOUNG, SAMWHA		
25		AL-CAPACITOR	50V 22uF (6.3φX 11) 85°C	1	C21	SAMYOUNG, SAMWHA		
26		AL-CAPACITOR	50V 4.7uF (6.3φX 11) 85°C	2	C16.C29	SAMYOUNG, SAMWHA		
27		AL-CAPACITOR	50V 1uF (6.3φX 11) 85°C	1	C65	SAMYOUNG, SAMWHA		
28		AL-CAPACITOR	25V 1000uF (12.5φX 25) 85°C	1	C31.57	SAMYOUNG, SAMWHA		
29		AL-CAPACITOR	25V 330uF (8φX 11) 85°C	3	C32.34.35.	SAMYOUNG, SAMWHA		
30		AL-CAPACITOR	16V 2200uF (10φX 21) 85°C	1	C27	SAMYOUNG, SAMWHA		
31		AL-CAPACITOR	16V 470uF (8φX 11) 85°C	2	C49.58	SAMYOUNG, SAMWHA		
32		AL-CAPACITOR	16V 100uF (6.3φX 11) 85°C	2	C14.24	SAMYOUNG, SAMWHA		
33		AL-CAPACITOR	10V/16V 2200uF (10φX 21) 85°C	1	C47	SAMYOUNG, SAMWHA		
34		AL-CAPACITOR	10V/16V 1000uF (10φX 16) 85°C	3	C48.53.54	SAMYOUNG, SAMWHA		
35		AL-CAPACITOR	10V/16V 470uF (6.3φX 11) 85°C	2	C28.50	SAMYOUNG, SAMWHA		
36		MONO-CAP	50V 104	10	C20.23.33.36.45.52.55.56.60.66	PILKO		
37		MY-CAP	50V 222	1	C15	PILKO, SUNIL		
38		MY-CAP	50V 472	1	C17	PILKO, SUNIL		
39		MY-CAP	50V 102	1	C22	SUNIL, SEORYONG		
40		MY-CAP	50V 152	1	C13	SUNIL, SEORYONG		



43	Y-CAP	222 Y1	1	C6	DAEMYUNG	
44	X-CAP	224 275V	3	C1.2.3	SUNIL	
45	MF-CAP	250V 225	1	C9	SUNIL	
46	MF-CAP	DC63V 105	1	C12	PILKO,SUNIL	
47	CF- RESISTOR	2W 5% 33K	1	R5	SORAK,HANBU	
48	CF- RESISTOR	2W 5% 2K	2	R39.40	SORAK,HANBU	
49	CF- RESISTOR	2W 5% 330	1	R52	SORAK,HANBU	
50	CF- RESISTOR	1W 5% 3.3K	1	R65	SORAK,HANBU	
51	CF- RESISTOR	1/2W 5% 3.3M	1	R1	PILKO	
52	CF- RESISTOR	1/2W 5% 1M	1	R2	SORAK,HANBU	
53	CF- RESISTOR	1/2W 5% 120K	2	R3.4	SORAK,HANBU	
54	CF- RESISTOR	1/2W 5% 10	2	R35.38	SORAK,HANBU	
55	CF- RESISTOR	1/2W 5% 2.2	1	R10	SORAK,HANBU	
56	CF- RESISTOR	1/2W 5% 1	1	R60	SORAK,HANBU	
57	CF- RESISTOR	1/4W 5% 15	2	R6.7	SORAK,HANBU	
58	CF- RESISTOR	1/8W 5% 100K	1	R65	SORAK,HANBU	
59	CF- RESISTOR	1/8W 5% 91K	1	R29	SORAK,HANBU	
60	CF- RESISTOR	1/8W 5% 75K	2	R27.14	SORAK,HANBU	
61	CF- RESISTOR	1/8W 5% 22K	1	R13	SORAK,HANBU	
62	CF- RESISTOR	1/8W 5% 10K	4	R17.19.32.56	SORAK,HANBU	
63	CF- RESISTOR	1/8W 5% 9.1K	1	R25	SORAK,HANBU	
64	CF- RESISTOR	1/8W 5% 7.5K	1	R55	SORAK,HANBU	
65	CF- RESISTOR	1/8W 5% 4.7K	6	R11.26.30.50.61.62	SORAK,HANBU	
66	CF- RESISTOR	1/8W 5% 2.2K	1	R53	SORAK,HANBU	
67	CF- RESISTOR	1/8W 5% 2K	1	R16.31	SORAK,HANBU	
68	CF- RESISTOR	1/8W 5% 1.5K	2	R15.34	SORAK,HANBU	
69	CF- RESISTOR	1/8W 5% 1K	5	R18.20.21.23.42	SORAK,HANBU	
70	MF- RESISTOR	1/8W 5% 680	1	R9	SORAK,HANBU	
71	MF- RESISTOR	1/8W 5% 510	1	R33	SORAK,HANBU	
72	MF- RESISTOR	1/8W 5% 180	1	R12	SORAK,HANBU	
73	LINEAR TRANS	48mm	1	T1	CHUN SAMNG	
74	DRIVE TRANS	EE1625(V)10PIN	1	T4	SAM HUNG	
75	CURRENT SENSE TRANS	IRON 13 C	1	T3	SAM HUNG	
76	LINE FILTOR	10mH MIN OR25/15/12	2	LF1.2	SAM HUNG	
77	MULTI COIL	COOLMU 33 PHI	1	MT1	SAM HUNG	
78	CHOKE COIL	0B 6*25 MIN 1.5uH	1	L1	SAM HUNG	
79	MAIN TRANS	EER4220(18PIN) MIN 2.7mH	1	T2	SAM HUNG	
80	MOV	10D471K	1	MOV1	SAM KYOUNG	
81	THERMISTOR	NTC 5D-15	2	TH1.2	SAM KYOUNG	
82	FUSE	5X20 250V 7A UL용,21806.3	1	F1	SAMJU,DONGWOO	
83	HEAT SINK		2	HS1.2	YOUNGKWANG,M&T,	KYUNGWON
84	HEAT SINK		1	HS3	YOUNGKWANG	
85	HEAT SINK		1	HS4	YOUNGKWANG	
86	JUMP WIRE	5mm	5	J2.3.5.6.11		

87		JUMP WIRE	6mm	3	J7.9.10		
88		JUMP WIRE	7mm	1	J4		
89		JUMP WIRE	10mm	2	J8.15		
90		JUMP WIRE	12mm	1	J12		
91		JUMP WIRE	15mm	1	J1		
92		FUSE CLIP		2		SAMJU,DONGWOO	
93		PCB	CM-1	1		WON HEUNG	
94		CONNECTOR	YW396-NNV (4-PIN)	1	CON4	YUN HO,HA RIM	
95		CONNECTOR	YW396-NNV (3-PIN)	3	CON1.2.3	YUN HO,HA RIM	
96		CONNECTOR	5267-09-01 (2.5mm)	1	CON6	YUN HO,HA RIM	
97		CONNECTOR	5267-08-01 (2.5mm)	1	CON5	YUN HO,HA RIM	
98		SCREW	M3*10	10			
99		SILICONE PAD RUBBER	24*19	2		M&T	

# SMPS

## 1. DESCRIPTION.

This document defines the functional requirement of KJP-3011 Power Supply.

This power supply is specially designed for AVD

This unit is intended to operate with indoor AC 120V voltage, KJP- 3011

and rated output is :+ 34/7.2A, +12V/150mA, -12V/70mA, +5V(AV) /500mA,

+5V(DV)/1A, -5V/100mA

VFD : -34V/40mA, FL $\pm$  (7.8V)/200mA,.

STAND-BY : 5.6V/50mA, M+5V/60mA

## 2. SCORE

This specification is intended to be used as an acceptance of electrical and mechanical characteristics for KJP-3011

## 3. REFERENCE

3-1. RELIABILITY TEST :

## 4. ELECTRICAL CHARACTERISTICS

4-1. AC INPUT CHARACTERISTICS

4-1-1. AC Input Rated Voltage : 120 Vac

4-1-2. AC Input operating Voltage : 110 ~ 130 Vac

4-1-3. AC Input Current : 120V / 4.3A,

4-1-4. Input Frequency : 47 ~ 63 Hz

4-1-5. Input Inrush Current : 50A max at 120 Vac

# SMPS

4-1-5-1. Input inrush current is measured with 120Vac input and output MAX.

4-1-5-2. Input inrush current is measured under condition of cold start.

4-1-6. Efficiency : 70 % minimum

4-1-6-1. Efficiency is measured with 120Vac input and output max.

4-1-7. Input On/Off cycle : 1 second minimum

## 4-2. DC OUTPUT CHARACTERISTICS

### 4-2-1. DC Output Voltage

#### 4-2-1-1. Output voltage regulation limit :

OUTPUT VOLTAGE	OUTPUT LOAD				TOLERANCE	RIPPLE & NOISE
	MIN	TYPE	MAX	PEAK		
+34V	0A		7.2A		±10%	150mV
+12V		150mA			±10%	70mV
-12V		70mA			±10%	50mV
+5V(AV)		500mA			±5%	50mV
+5V(DV)		1A			±5%	50mV
-5V		100mA			±5%	50mV
ST(+5.6)		50mA			±5%	50mV
M+5V		60mA			±10%	150mV
-34		40mA			±10%	150mV
FL±7.8V		200mA			±10%	

4-2-1-2. The unit shall meet voltage regulation limit under all input voltage range.

#### 4-2-1-3. On/Off Control

High(3.5 ~ 5V) Main on.

Low or Open(0V) Main off..

#### 4-2-2. Ripple and Noise

4-2-2-1. Ripple and noise shall be measured at the end of output and with a 47uF EL-Capacitor and a 0.1uF ceramic capacitor between output to ground.

4-2-2-2. Ripple and noise shall be measured with 20MHz bandwidth.

# SMPS

## 4-3. ABNORMAL CONDITION AND REQUIRED RESPONSE

### 4-3-1. Output Short Circuit Protection

4-3-1-1. On the output, Application of a short-circuit to ground shall not be damaged to the power supply.

4-3-1-2. When short problem is occurred, Hiccup or Fold back

After removing of short, the power supply will be auto-recovered

### 4-3-2. Min Load Operation.

4-3-2-1. The power supply shall not be damaged by on load operation.

4-3-2-2. The power supply does not required to maintain output voltage within regulation limit.

### 4-3-3. Overload Protection

4-3-3-1. Input : AC 120V

Output : 120% Minimum

## 4-4. Safety Agency and Regulatory

### 4-4-1. Safety Agency

4-4-1-1. Safety :UL.CSA.Meete

### 4-4-2 HI-POT and Insulation Resistance

4-4-2-1. Dielectric Withstanding Voltage

Primary to Secondary : 2.5K Vac, 1Minite.

For production test procedure, the duration is 1 sec.

# SMPS

MODEL NO: KJP-3011

4-4-2-2. Hi-pot test is performed with minimum 10mA cut-off current.

4-4-2-3. Insulation resistance : MIN 100M (Primary to Secondary)

4-4-3. EMI

4-3-3-1. FCC class B. Meete

4-5. Environmental Requirements

4-5-1. Operating Temperature : 0 to 40

4-5-2. Storage Temperature : -40 to 85

4-5-3. Operating Humidity : 20 to 80% RH

4-5-4. Storage Humidity : 10 to 90% RH

4-5-5 ALTITUDE

Operating : 10,000 ft

Storage : 50,000ft

## **5. MEAN TIME BETWEEN FAILURES(MTBF)**

50,000 hours (full load and 25 ambient conditions)

## **6. BURN-IN**

TEST CONDITION

4 hours referance (@70% Load min., 40 , 120Vrms)

# TUNER SCHEMATICS

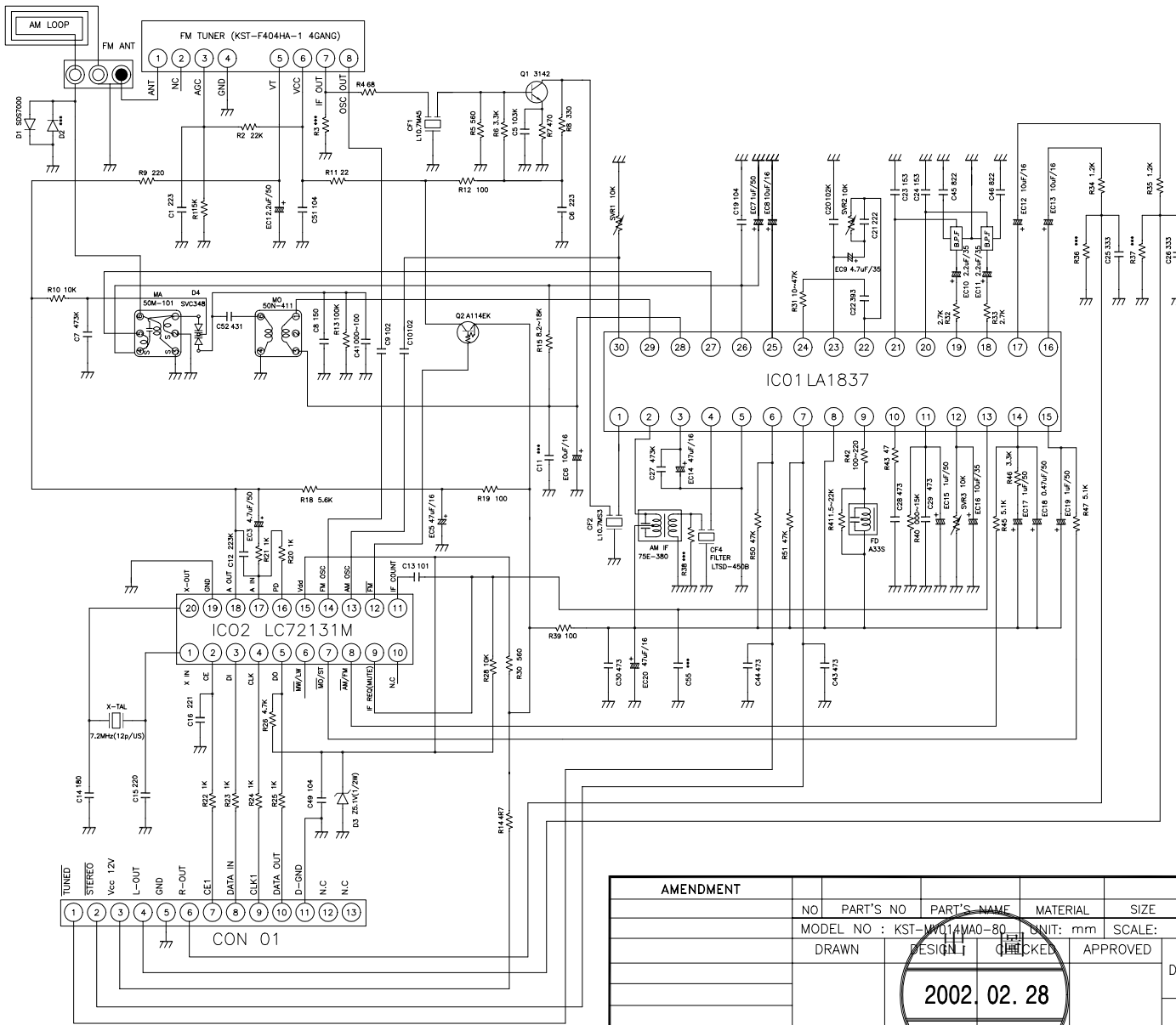

AMENDMENT							
NO	PART'S NO	PART'S NAME	MATERIAL	SIZE	TREATMENT	REMARK	
MODEL NO : KST-JW014MA0-80			UNIT: mm	SCALE:	DATE: 02. 02. 28.		
DRAWN	DESIGN	CHECKED	APPROVED	DRAW NO		KSD-M081-65	
<div style="text-align: center;"> <p>2002. 02. 28</p> <p>(株)光星電子</p> <p>技術部</p> </div>				NAME		SCHEMATIC DIAGRAM	

\*Note. The Component values of this Schematic diagram are subject to change without notice for improvement.





**1. APPLICATION**

This specification cover the tuner to be used for AM#FM broadcast reception, which AM#FM Front End with Detector, MPX.

**2. APPENDED DOCUMENTS**

2-1. Dimensions and terminal connection.

Refer to the attached drawing No. ( TCS - 082 - 80R )

2-2. Schematic diagram

As shown in the attached drawing No. ( KSD - M081 - 65 )

**3. RECEIVING METHOD**

AM#FM section is designed super heterodyne receiving circuit with RF.

Amp ( As shown in the attached drawings )

**4. ELECTRICAL SPECIFICATION & CHARACTERISTICS****4-1. Electrical specification**

NO	ITEMS	SPECIFICATION	
		M W	F M
4-1-1	Local OSC	Above the receiving Frequency	
4-1-2	Frequency cover range	520 ~ 1720kHz	87.5 ~ 108.0MHz
4-1-3	Intermediate Frequency	450 kHz	10.7 MHz
4-1-4	Standard supply voltage	12 +/- 0.5V	
4-1-5	Current drain	80 +/- 20mA	
4-1-6	FM Antenna impedance	75 ohm unbalance	
4-1-7	AM Loop Antenna inductance	15uH(S0146BL-101)	

**4-2. PLL Selector (LC72131).**

NO	ITEMS	IC PIN NO	
4-2-1	FM	8	H gh
4-2-2	AM	8	LOW
4-2-3	MW	6	LOW
4-2-4	LW	6	H gh
4-2-5	MD	7	LOW
4-2-6	ST	7	H gh
4-2-7	I F Reg<mute>	9	H gh
4-2-8	FM	12	LOW

## 4-3. ELECTRICAL CHARACTERISTICS (M/V)

NO	TEST ITEMS	TEST CONDITION	T. P.	T. L.	MOD.	SPECIFICATION			UNIT
			kHz	dBu	%	MIN	TYP	MAX	
1	FREQUENCY RANGE	LOW	--	--	--		520		kHz
		HIGH	--	--	--		1720		
2	IF FREQUENCY	-----	--	--	--	448	450	452	kHz
3	USABLE SENS.	at S/N=20dB	600						dBu
			1000	--	30	--	55	63	
			1400						
4	GAIN BALANCE	at usable sens.	600						dB
			1000	--	30	--	5	10	
			1400						
5	IMAGE REJECTION	at usable sens.	1000	--	30	30	33	--	dB
6	IF REJECTION	at usable sens.	1000	--	30	40	45	--	dB
7	1 SIGNAL SELECTIVITY	± 10kHz	990						dB
			1010	--	30	20	25	--	
8	DISTORTION	-----	1000	74	30	--	1.5	3.0	%
				100	80	--	3.0	5.0	
9	S/N RATIO	-----	1000	80	30	40	45	--	dB
10	AGC EFFECT	at OUTPUT - 10dB	1000	100	30	45	50	--	dB
11	TWEET	-----	900	74	30	--	--	10	%
12	AF OUTPUT LEVEL	47kΩ LOAD	1000	74	30	115	165	215	mV
13	AUTO STOP LEVEL		600						dBu
			1000	--	30	45	55	65	
			1400						
14	AUDIO RESPONSE (400Hz = 0dB)	-6dB Point Low High	1000	74	30	--	60	100	Hz
						1.8	2.0	--	kHz

## 4-4. ELECTRICAL CHARACTERISTICS (FM)

NO	TEST ITEMS	TEST CONDITION	T. P.	T. L.	MOD.	SPECIFICATION			UNIT
			MHz	dBu	kHz	MIN	TYP	MAX	
1	FREQUENCY RANGE	LOW	--	--	--		87.5		MHz
		HIGH	--	--	--		108.0		
2	I F FREQUENCY	-----	--	--	--	10.5	10.7	10.9	MHz
3	USABLE SENS.	at S/N=30dB	90.0						dBu
			98.0	--	75	--	6	12	
			106.0						
4	GAIN BALANCE	at usable sens.	90.0						dB
			98.0	--	75	--	3	5	
			106.0						
5	I F REJECTION	at usable sens.	90.0	--	75	70	80	--	dB
6	I MAGE REJECTION	at usable sens.	106.0	--	75	70	80	--	dB
7	S/N RATIO		98.0	60	75	60	65	--	dB
8	AM SUPPRESSION	at AM 30% 1kHz	98.0	60	75	40	50	--	dB
9	DI STORTION	MONO	98.0	60	75	--	0.5	0.8	%
10	OVER LOAD DI STORTION	MONO	98.0	120	75	--	1.0	2.0	%
11	AUTO STOP LEVEL		90.0						dBu
			98.0	--	75	18	23	28	
			106.0						
12	STEREO SEPARATION MAIN 90% PI LOT 10%	100 Hz				30	35		dB
		1 kHz	98.0	60		35	40	--	
		10 kHz				25	30		
13	AUDIO RESPONSE (1kHz=0dB)	De-emphasis/75us Low	98.0	60	75	--	--	50	Hz
		(-3dB) High				12	14	--	kHz
14	AF OUTPUT LEVEL	47kΩ LOAD	98.0	60	75	470	600	730	mV

# PCB DRAWINGS

DPR-1001 VFD PCB  
A1R-594

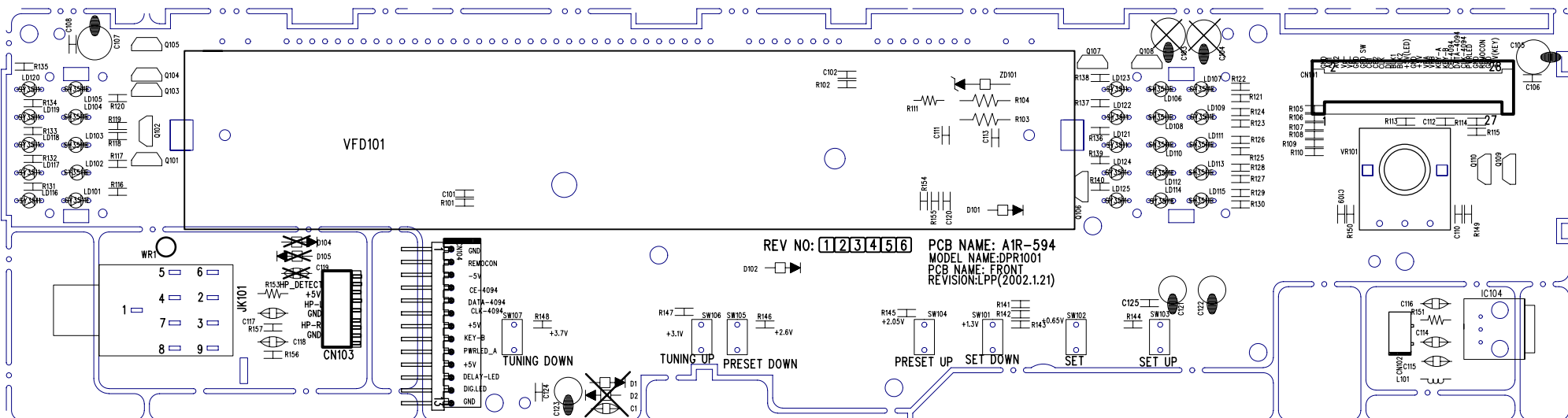

DPR-1001 VFD PCB TOP  
A1R-594

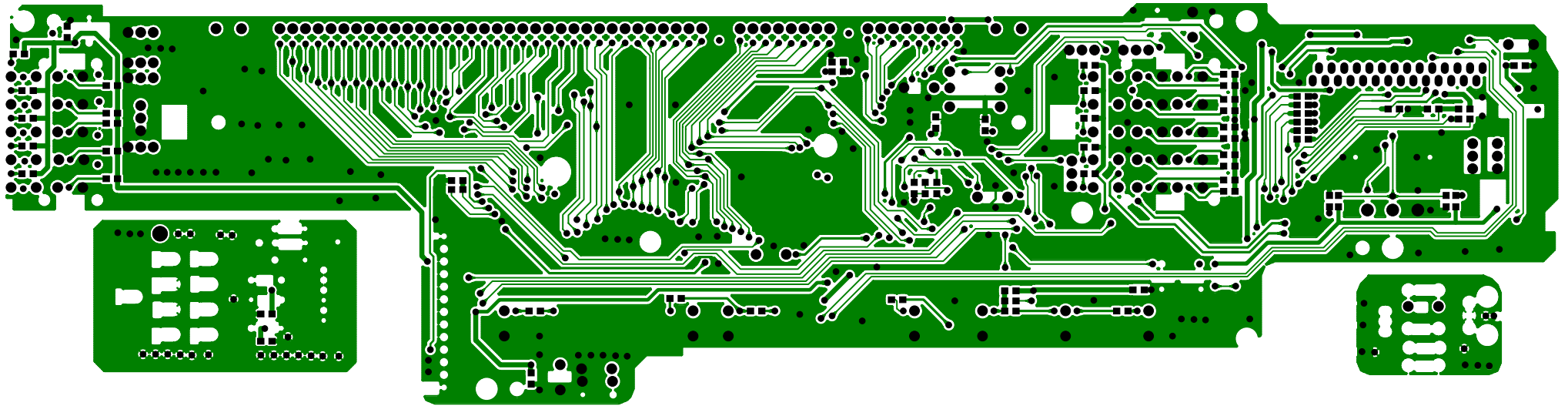

DPR-1001 VFD PCB BOT  
A1R-594

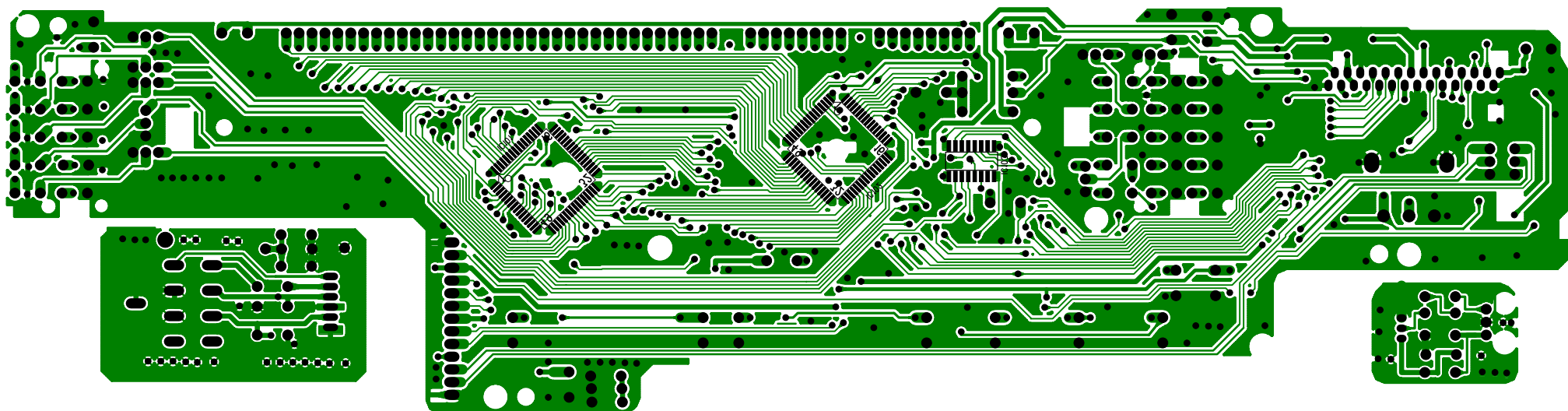

DPR-1001 KEY PCB  
A1R-603

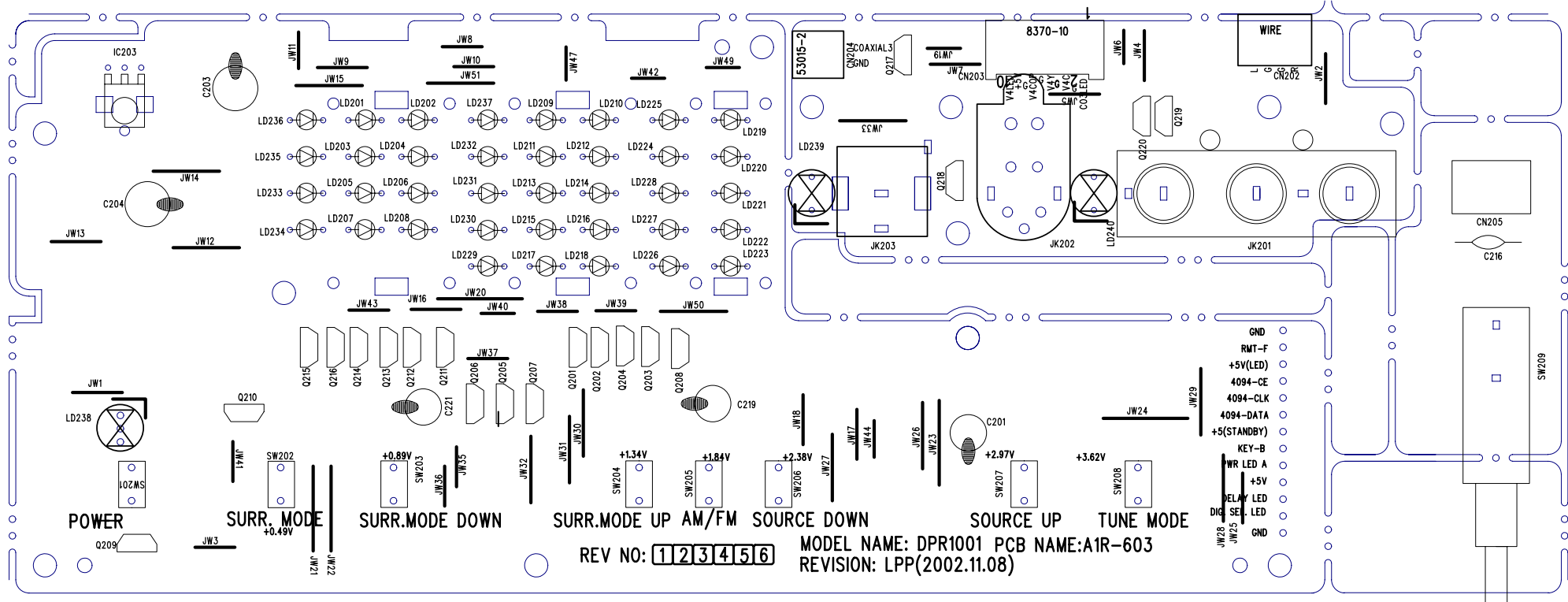

DPR-1001 KEY PCB  
A1R-603

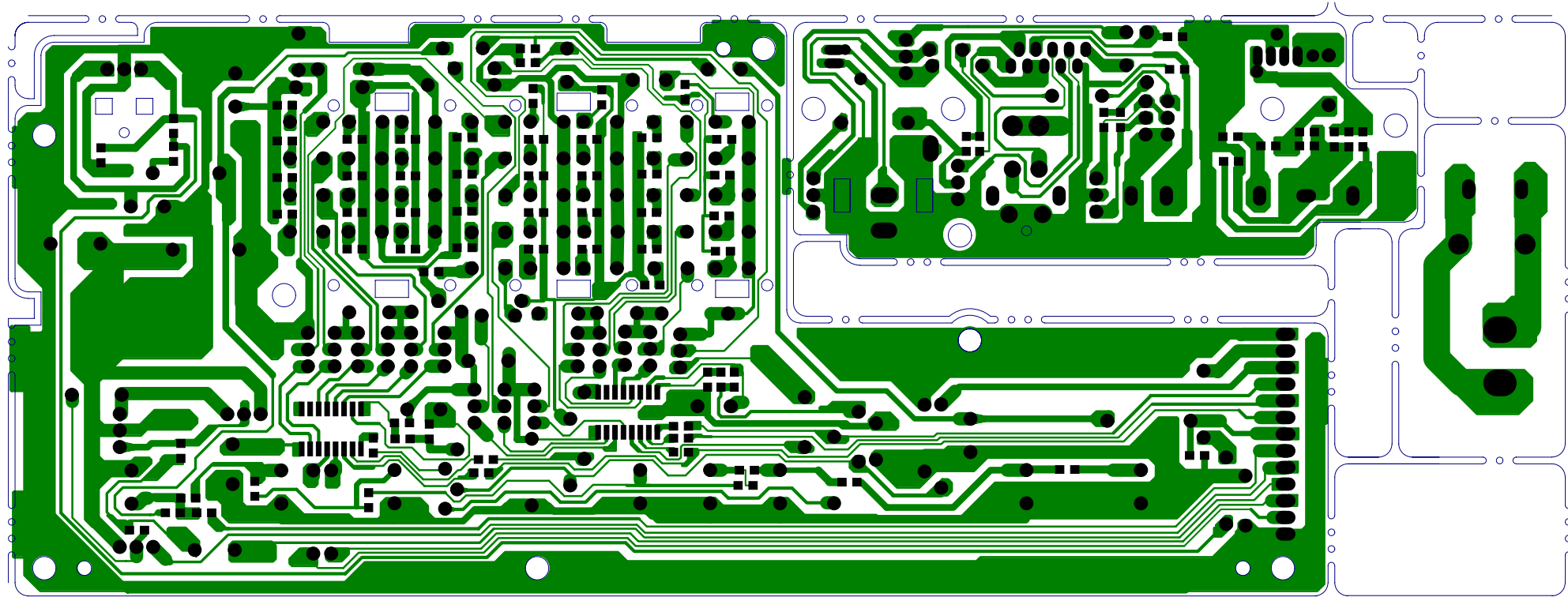





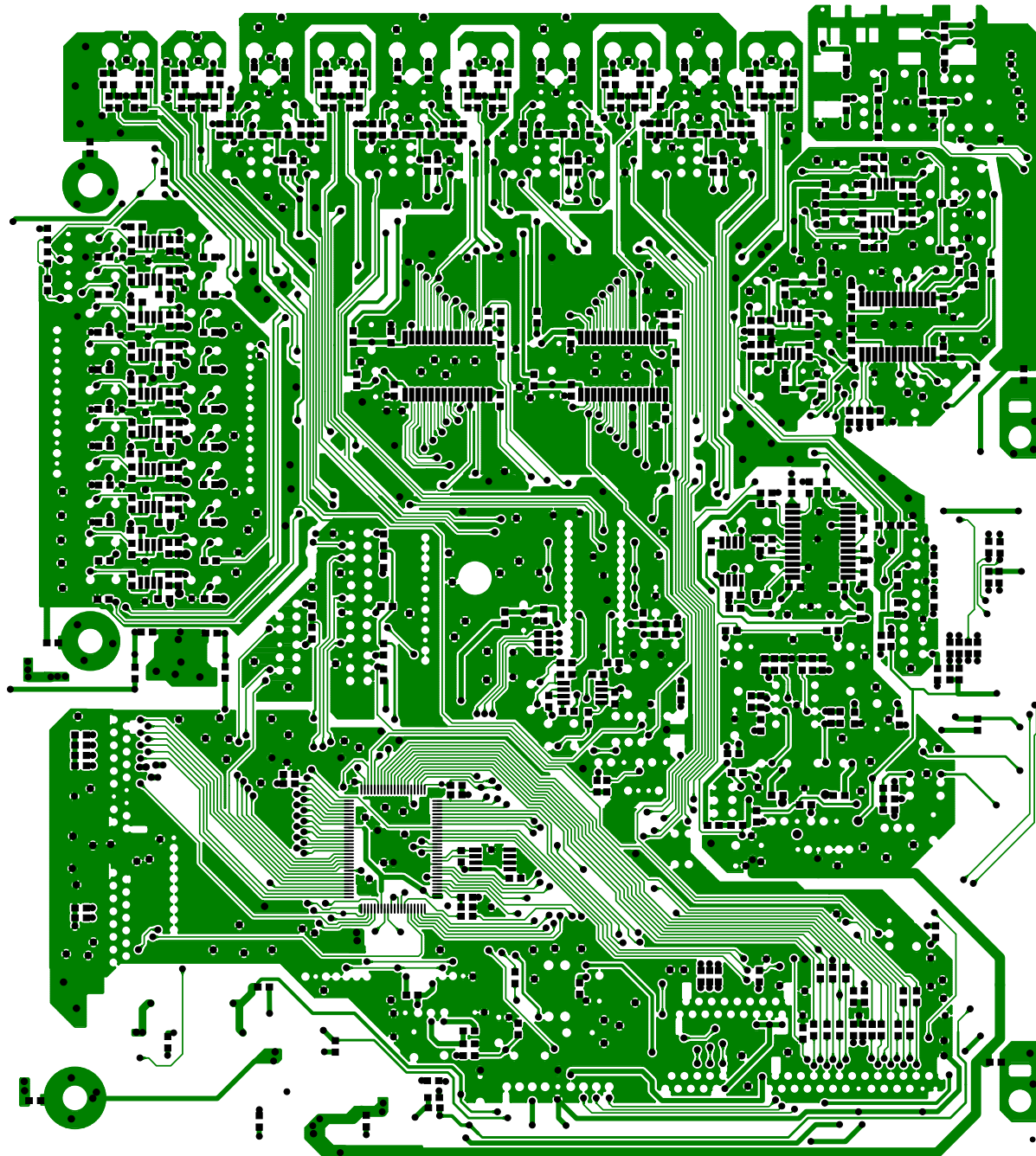

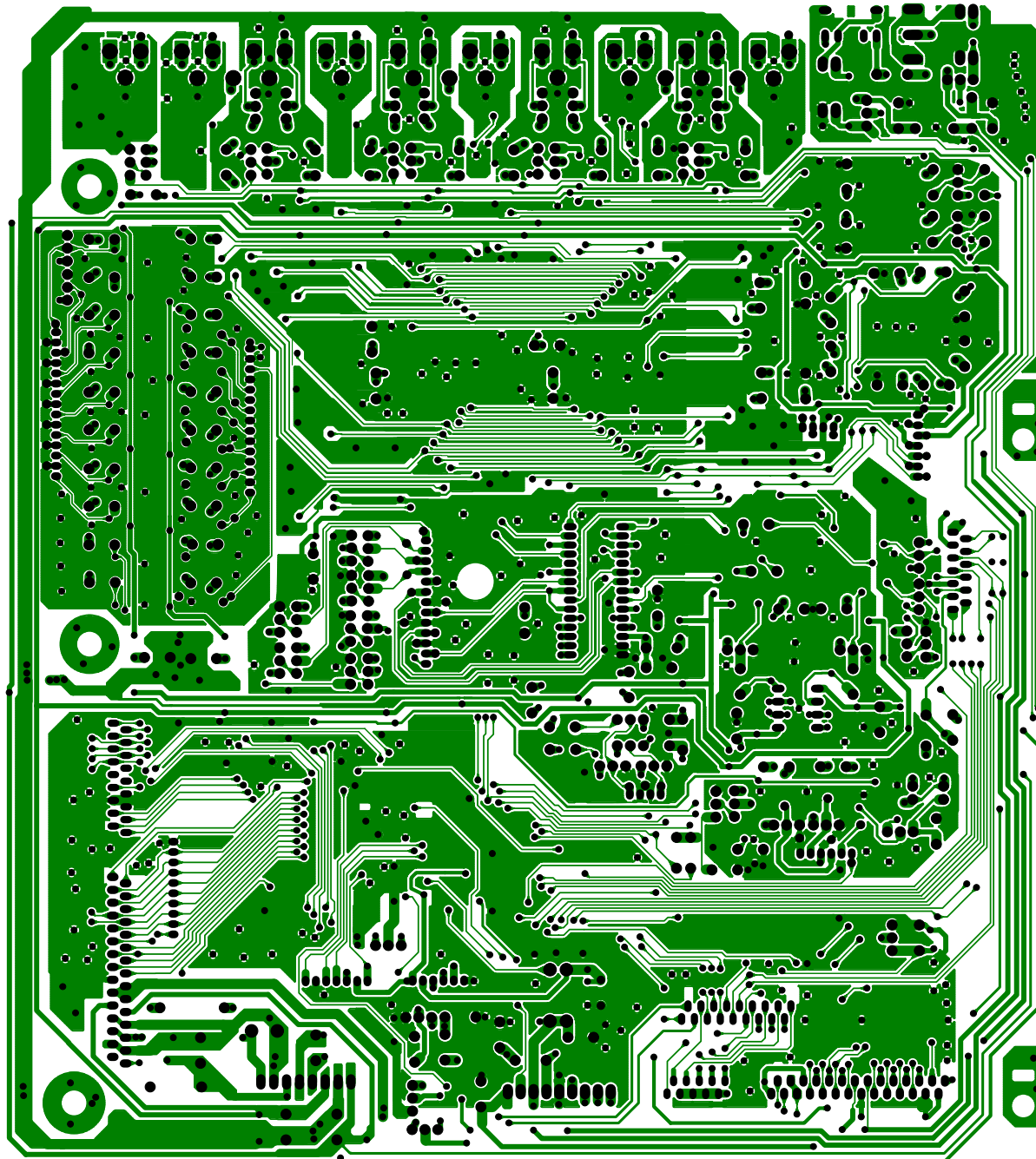

# DPR1001 PWM\_DSP PCB

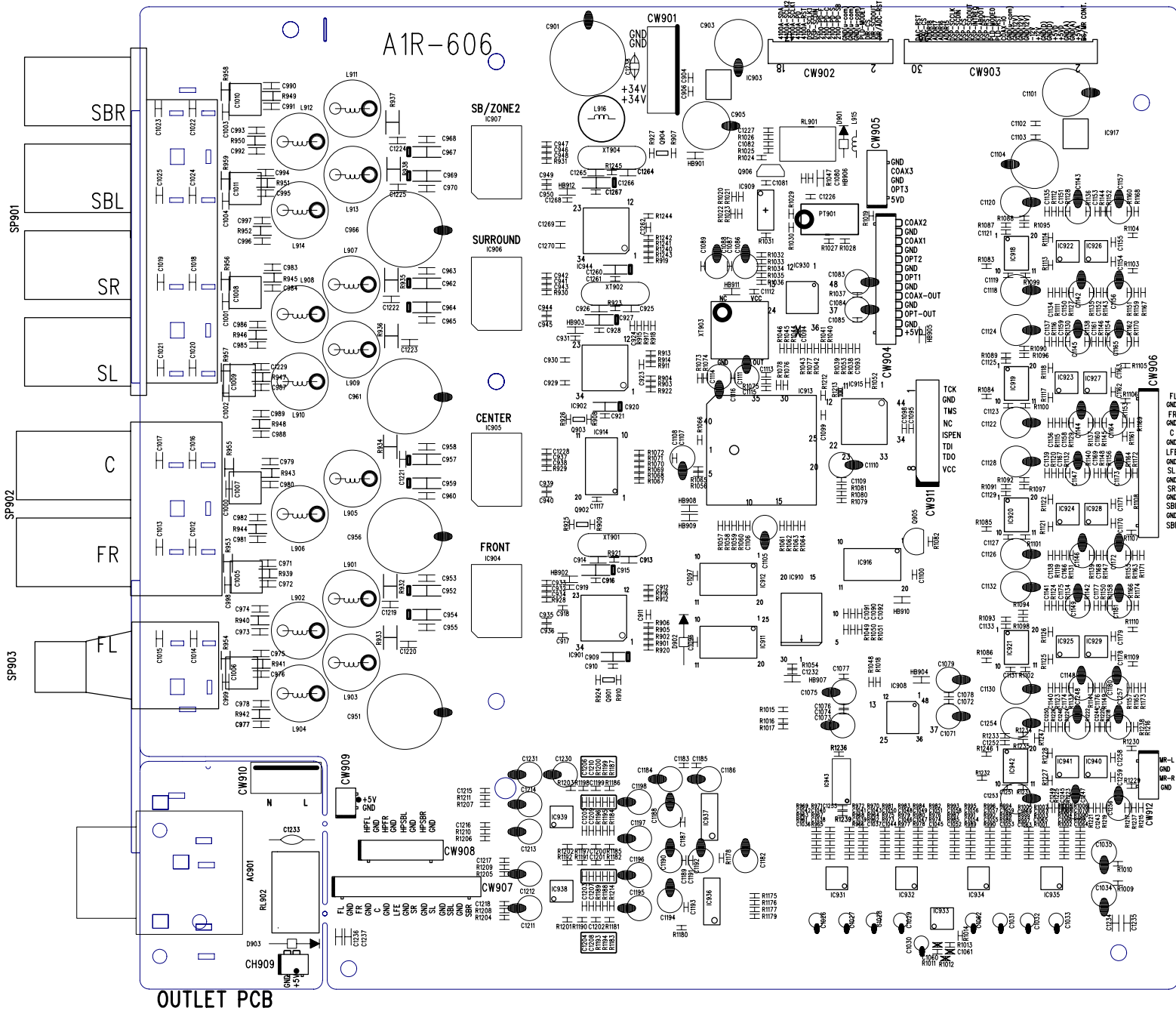

DPR1001 PWM\_DSP TOP  
A1R-606

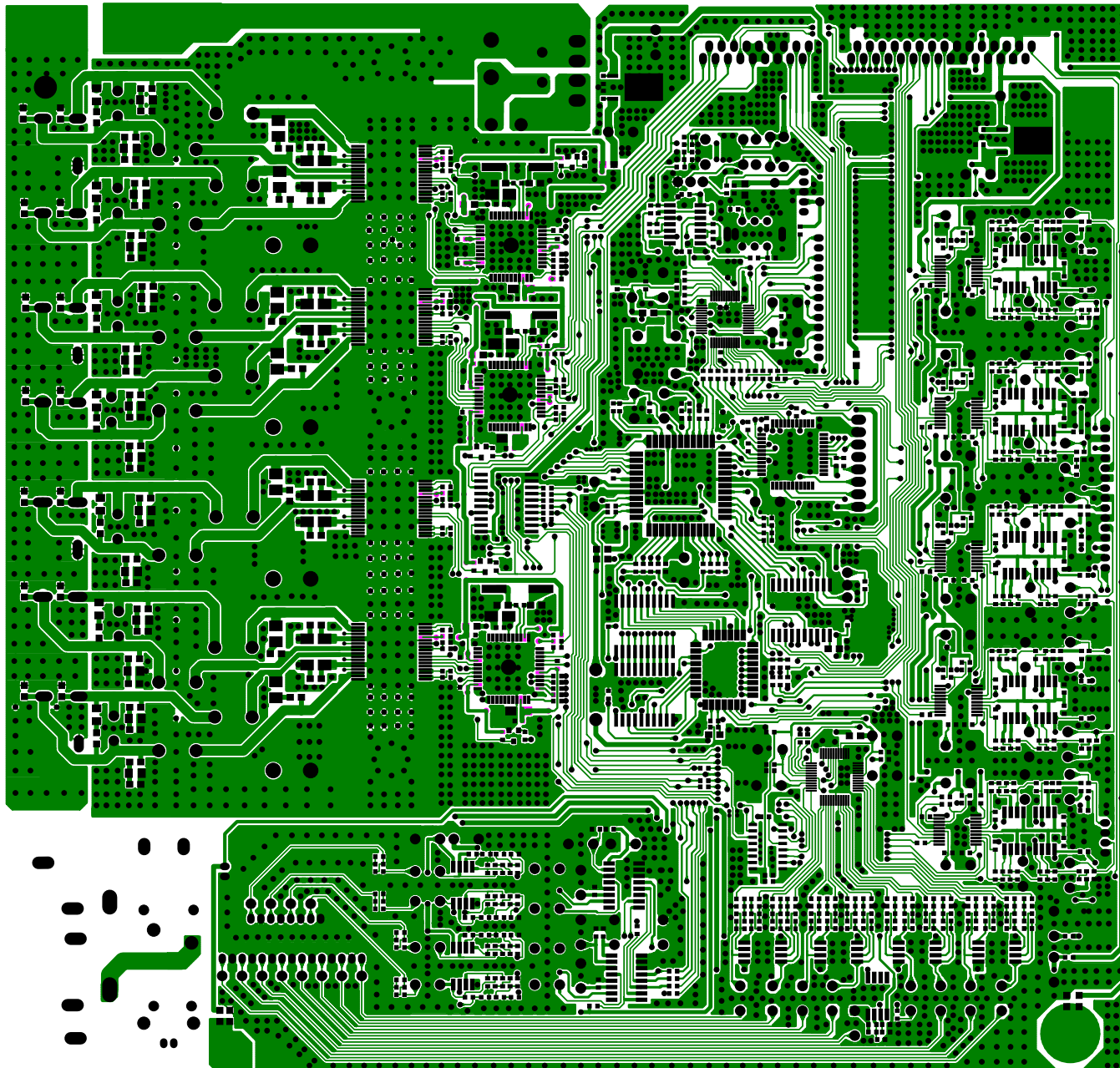

OUTLET PCB

DPR1001 PWM\_DSP BOT  
A1R-606

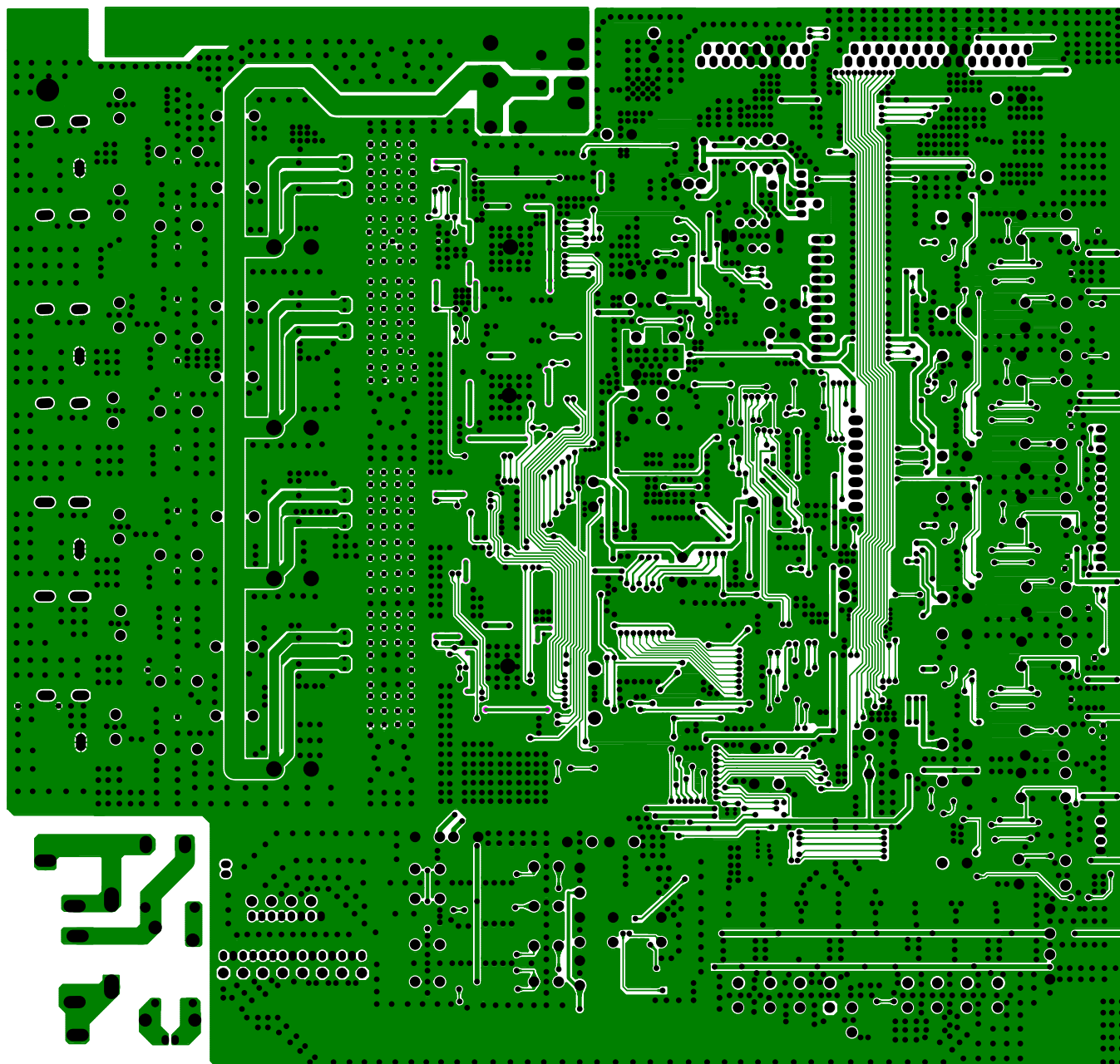

OUTLET PCB

# DPR-1001 VIDEO PCB A2R-213

8CH PRE-OUT PCB

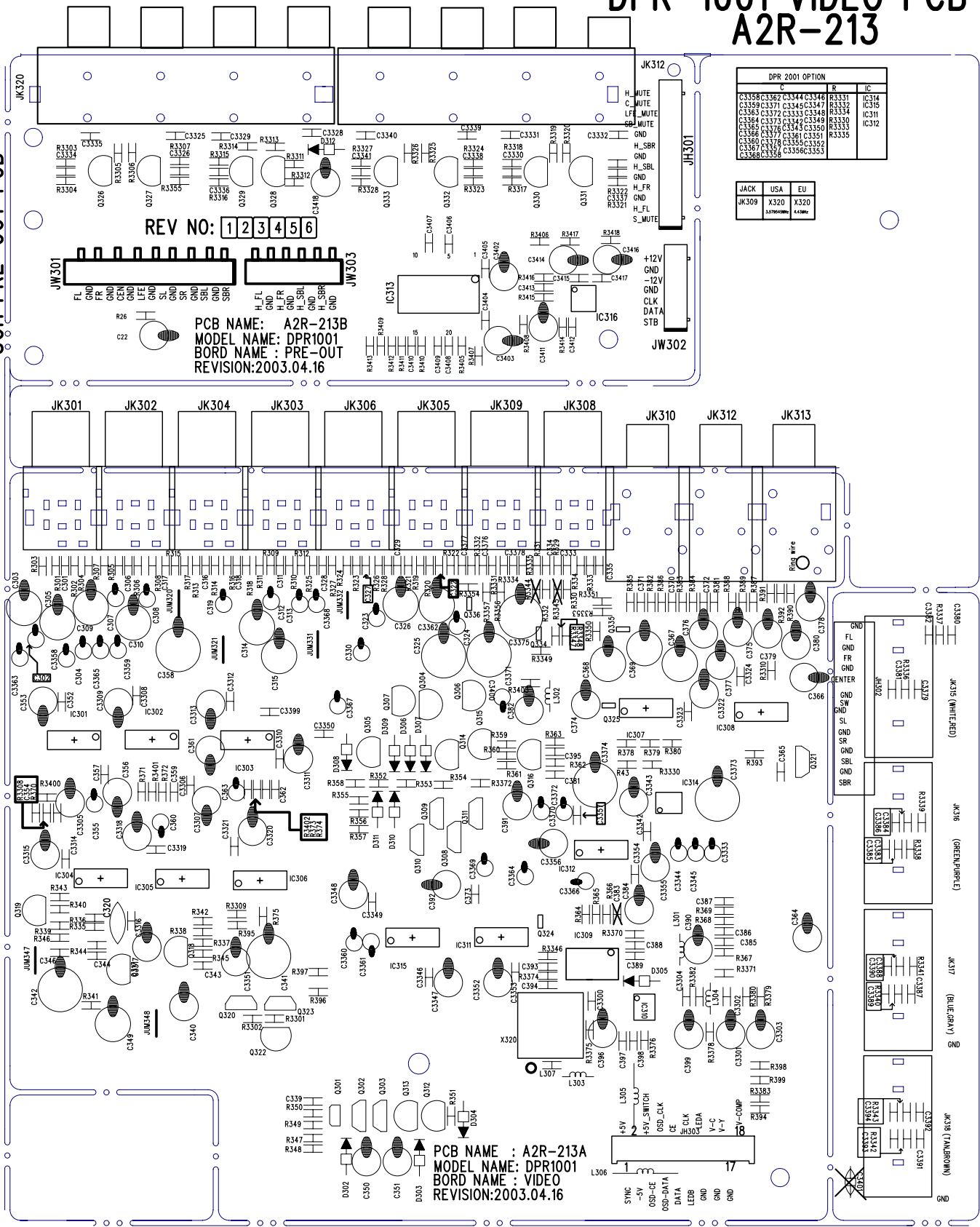

REV NO: 1 2 3 4 5 6

PCB NAME: A2R-213B  
 MODEL NAME: DPR1001  
 BOARD NAME: PRE-OUT  
 REVISION: 2003.04.16

DPR 2001 OPTION			
IC	R	C	IC
C3356	C3362	C3344	C3346
R3331	R3332	R3333	R3334
C3359	C3371	C3346	C3347
R3365	R3372	R3333	R3348
C3364	C3373	C3349	C3349
R3366	R3376	R3348	R3350
C3380	C3377	C3381	C3351
R3367	R3378	R3355	R3352
C3367	C3387	C3356	C3355
R3368	R3388	R3356	R3355

JACK	USA	EU
JK309	X320	X320
	1.875(40)	4.1MM

PCB NAME : A2R-213A  
 MODEL NAME: DPR1001  
 BOARD NAME : VIDEO  
 REVISION: 2003.04.16

8CH PRE-IN PCB

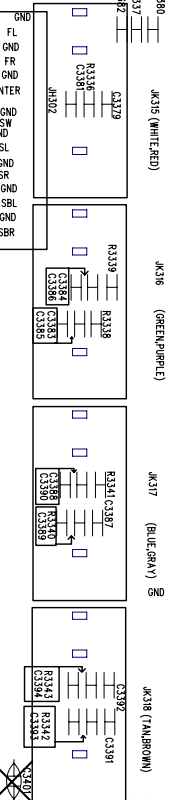

# DPR-1001 VIDEO PCB TOP A2R-213

8CH PRE-OUT PCB

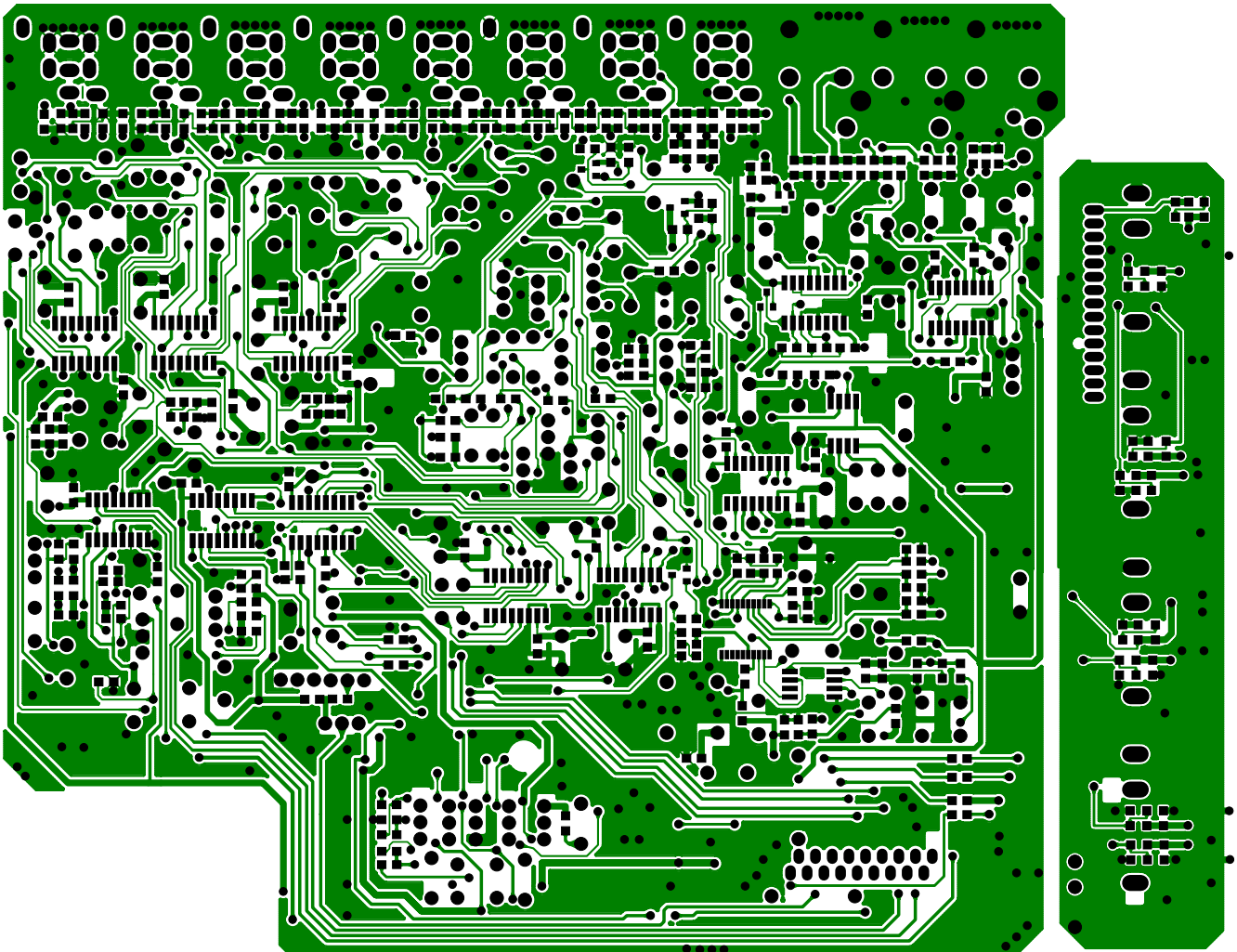
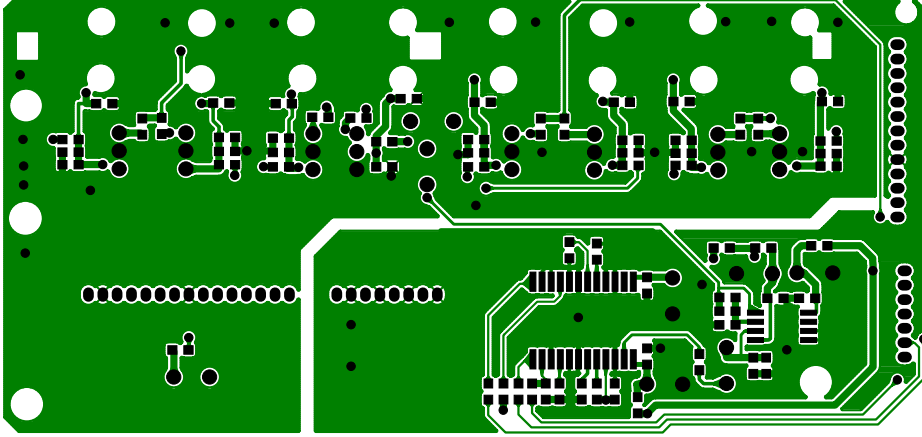

8CH PRE-IN PCB



DPR-1001 VIDEO PCB BOT  
A2R-213

8CH PRE-OUT PCB

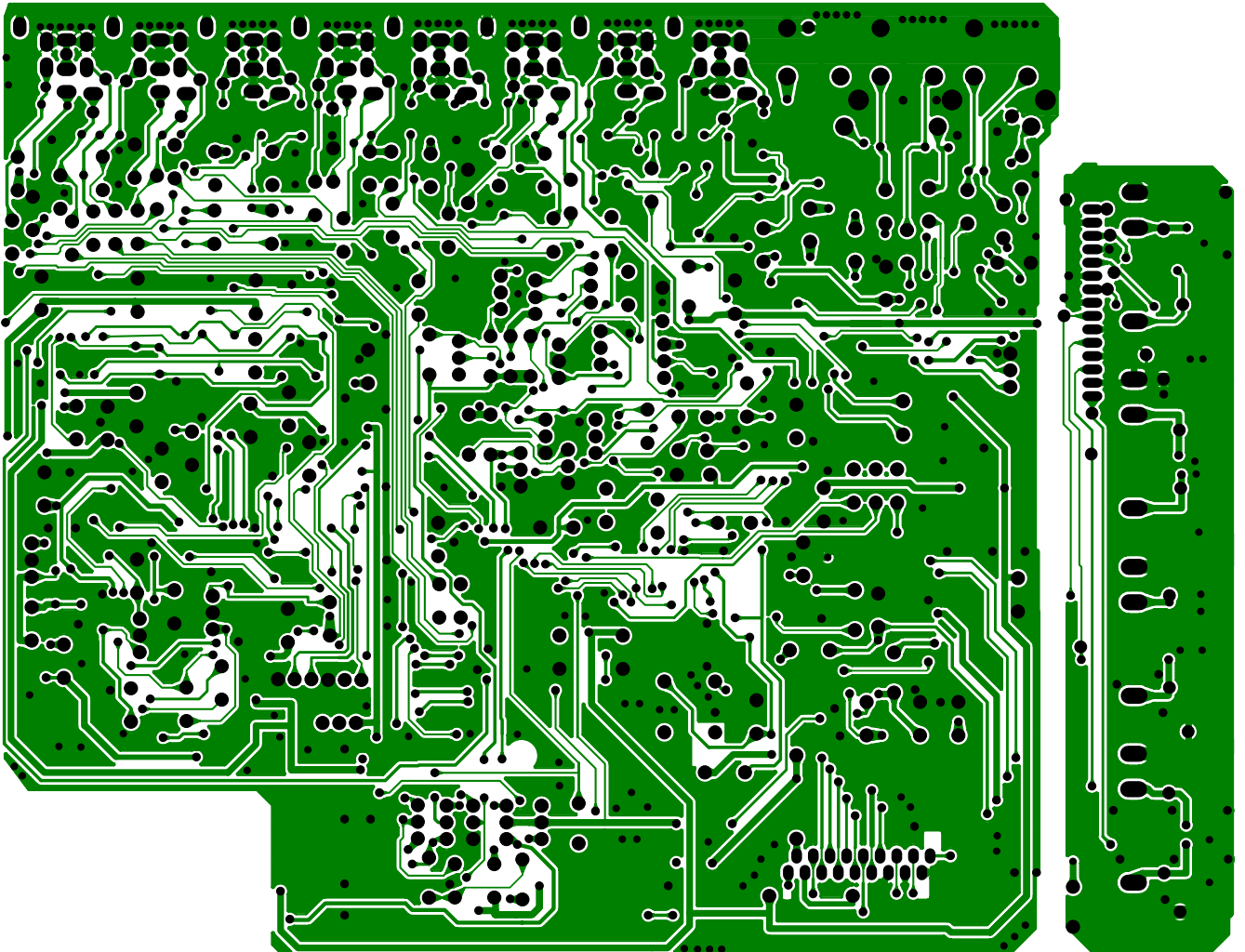
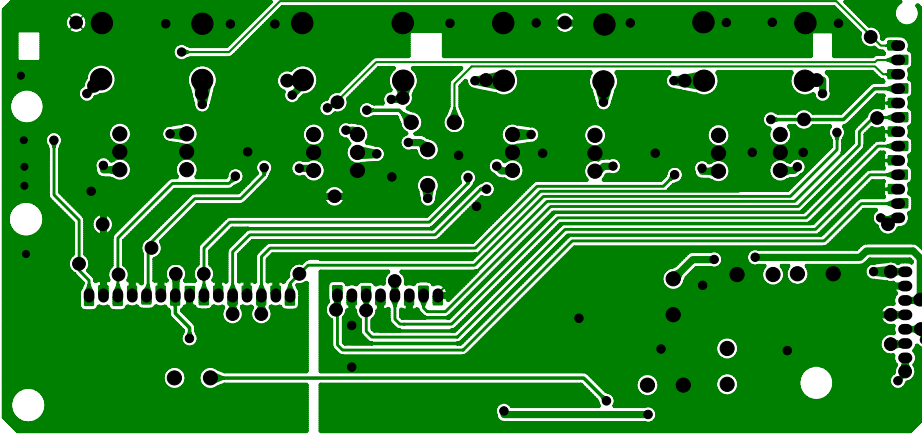

8CH PRE-IN PCB

# PCB DRAWINGS

## 6. Digital Input

### DPR-1001 DIGITAL INPUT PCB A1R-612

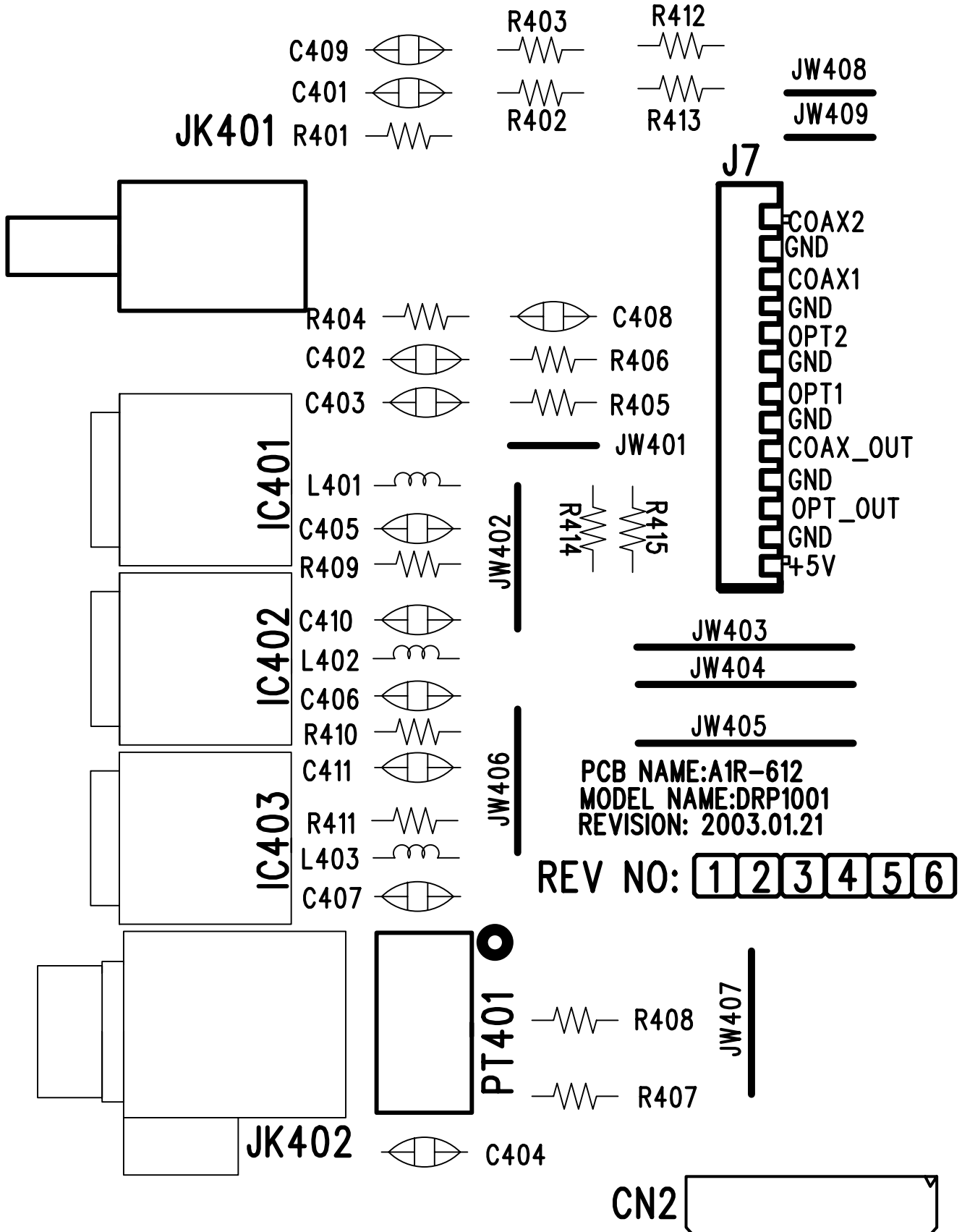

PCB DRAWINGS

DPR-1001 DIGITAL INPUT PCB  
A1R-612

6. Digital Input

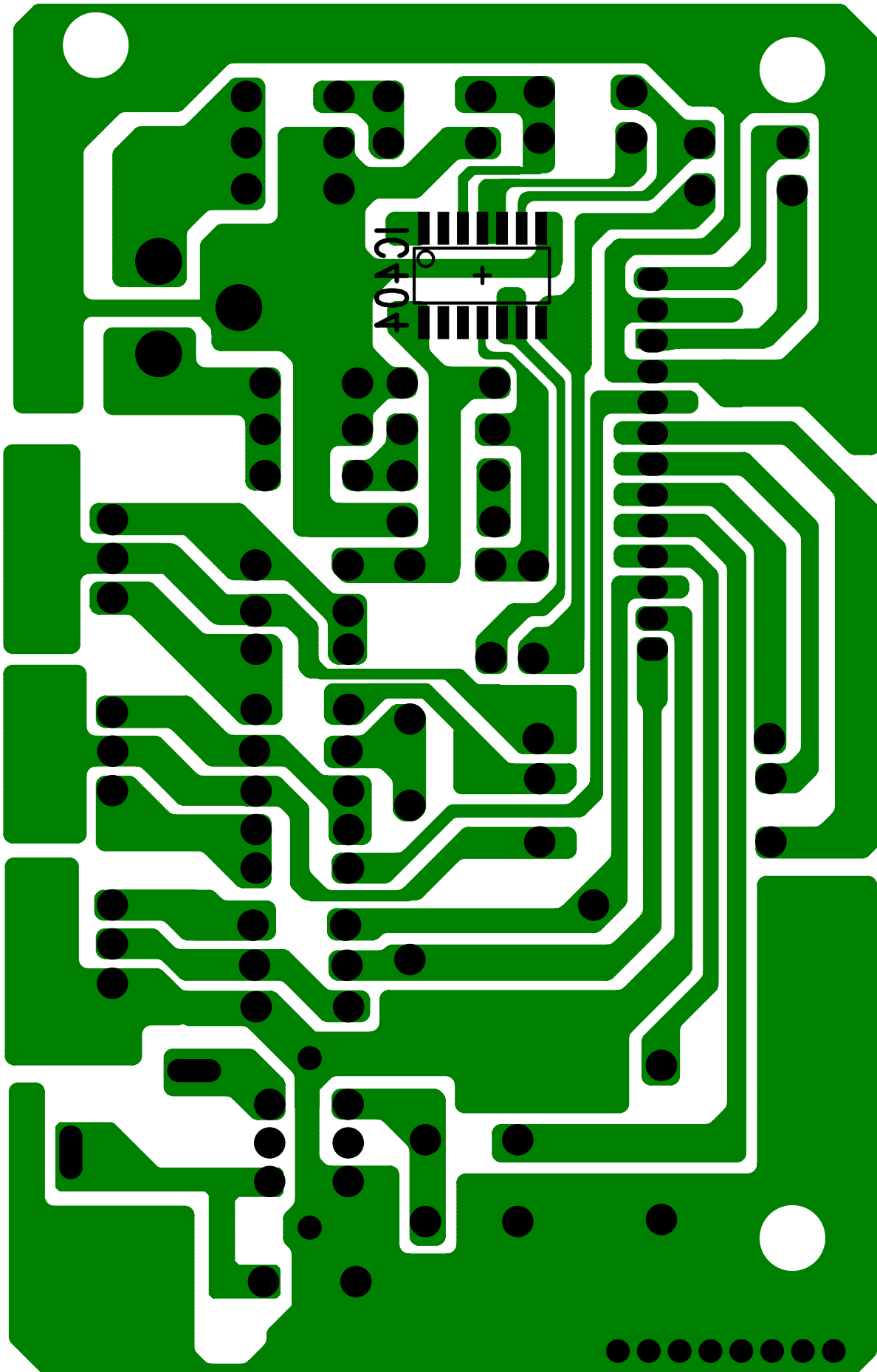

# SMPS POWER SUPPLY

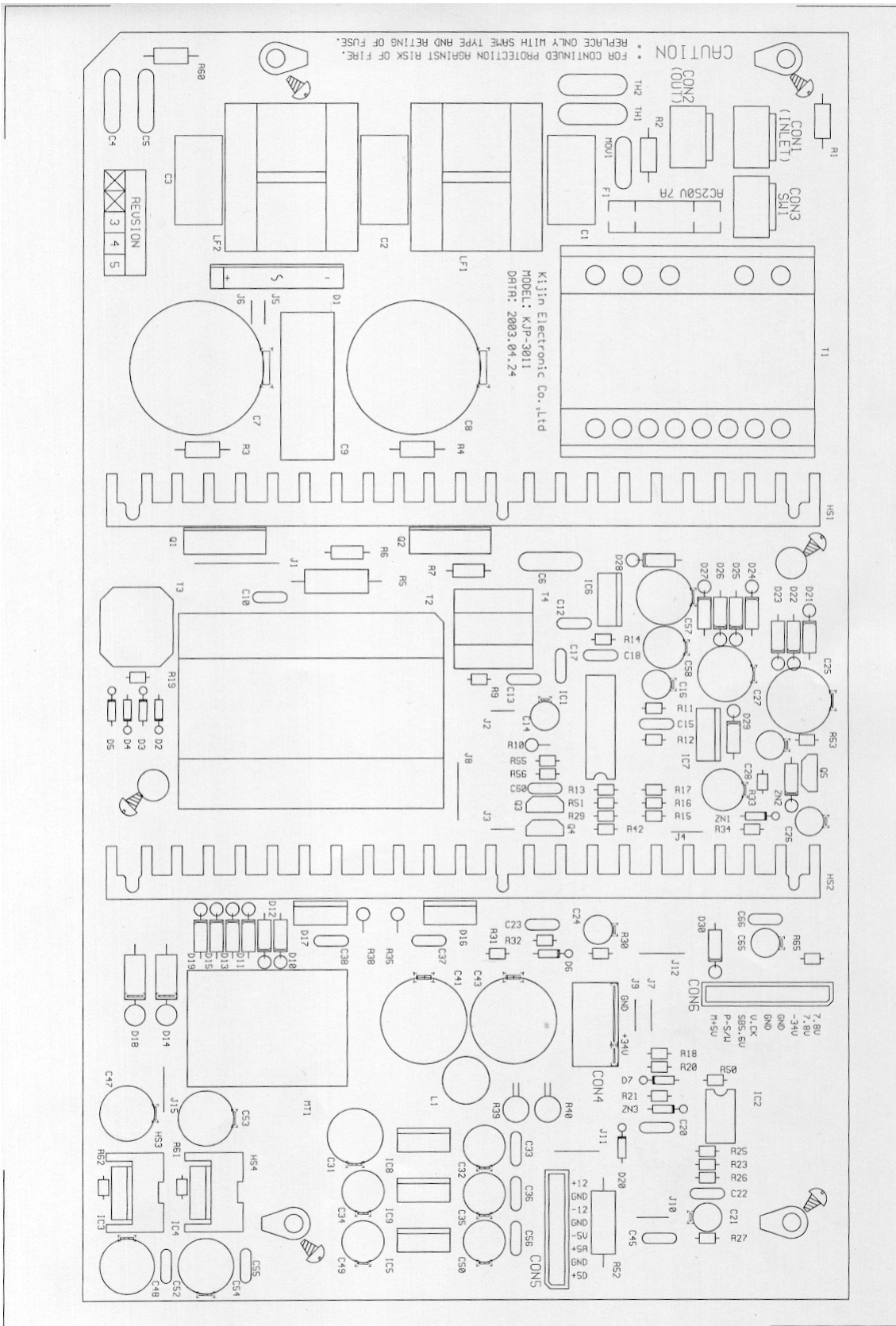

# SMPS POWER SUPPLY

CAM350 V 5.0 : Fri Apr 25 15:48:31 2003 - (Untitled)

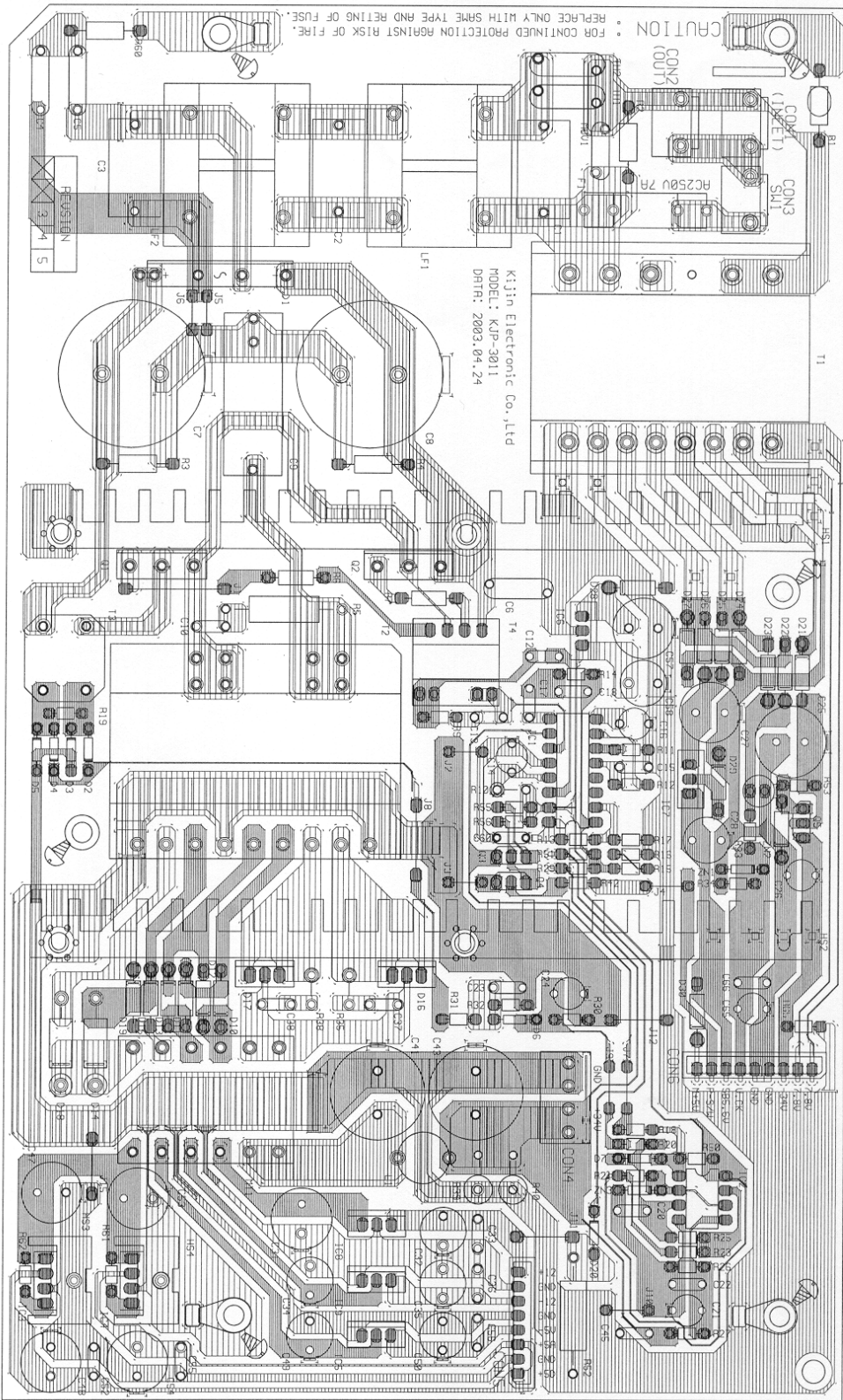

CAUTION : FOR CONTINUED PROTECTION AGAINST RISK OF FIRE, REPLACE ONLY WITH SAME TYPE AND RATING OF FUSE.

Kijin Electronic Co., Ltd  
MODEL: KJP-3011  
DHR: 2003.04.24

# PCB DRAWINGS

KWANG SUNG ELECTRONICS CO., LTD.

## 8. Tuner

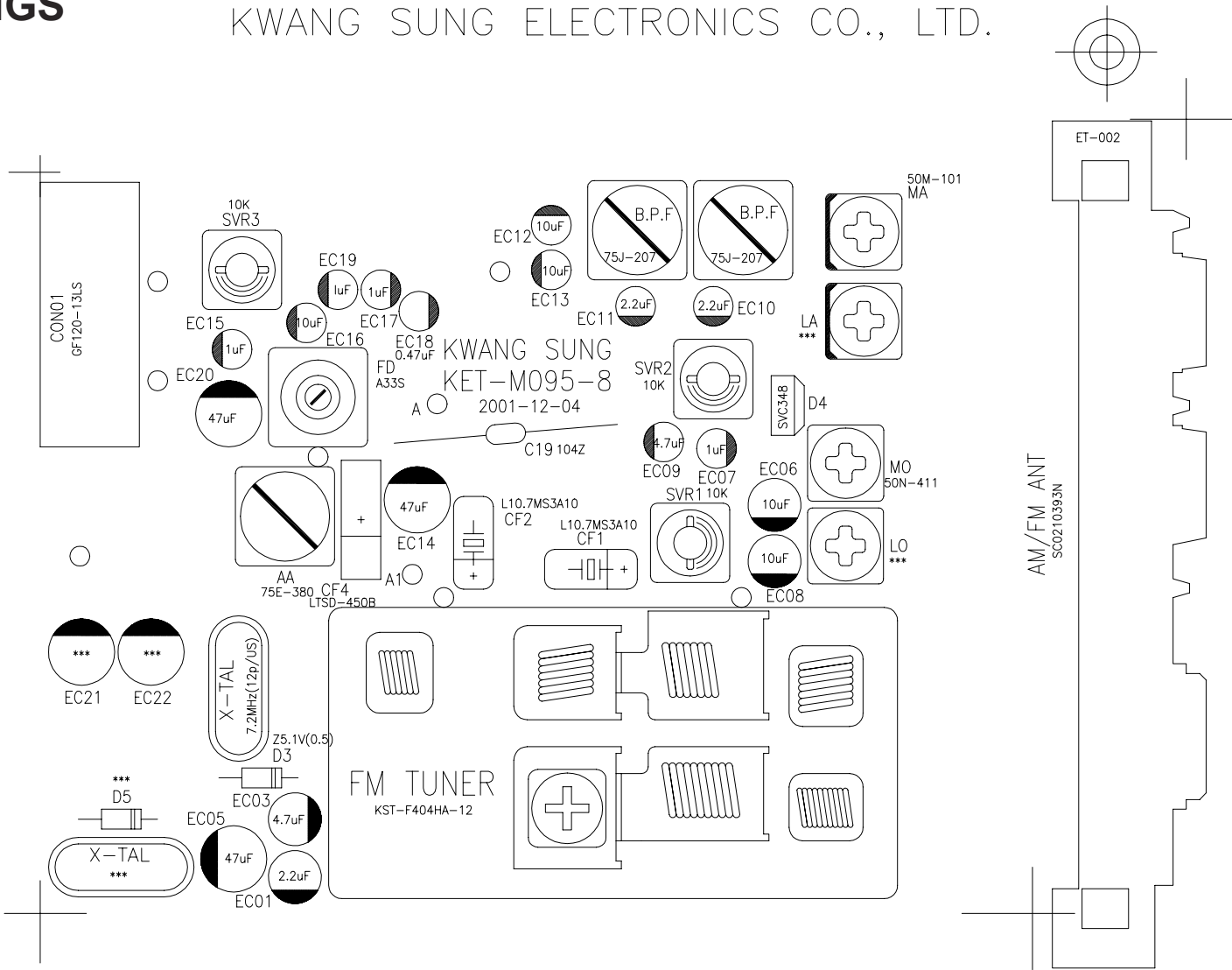

SC-031B-6

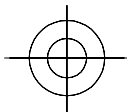

MODEL	KST-MV014MA0-80	SCALE	1 : 1
DRAWN NO	KETM095-8	VIEW	TOP VIEW

SAMLE : 10 PCS XPC 1.6t 2003. 01. 22  
 :  $\phi 0.8$  :  $\phi 0.9$  :  $\phi 0.95$  :  $\phi 1.0$  :  $\phi 1.1$  :  $\phi 1.2$  :  $\phi 0.8$

PCB DRAWINGS

KWANG SUNG ELECTRONICS CO., LTD.

8. Tuner

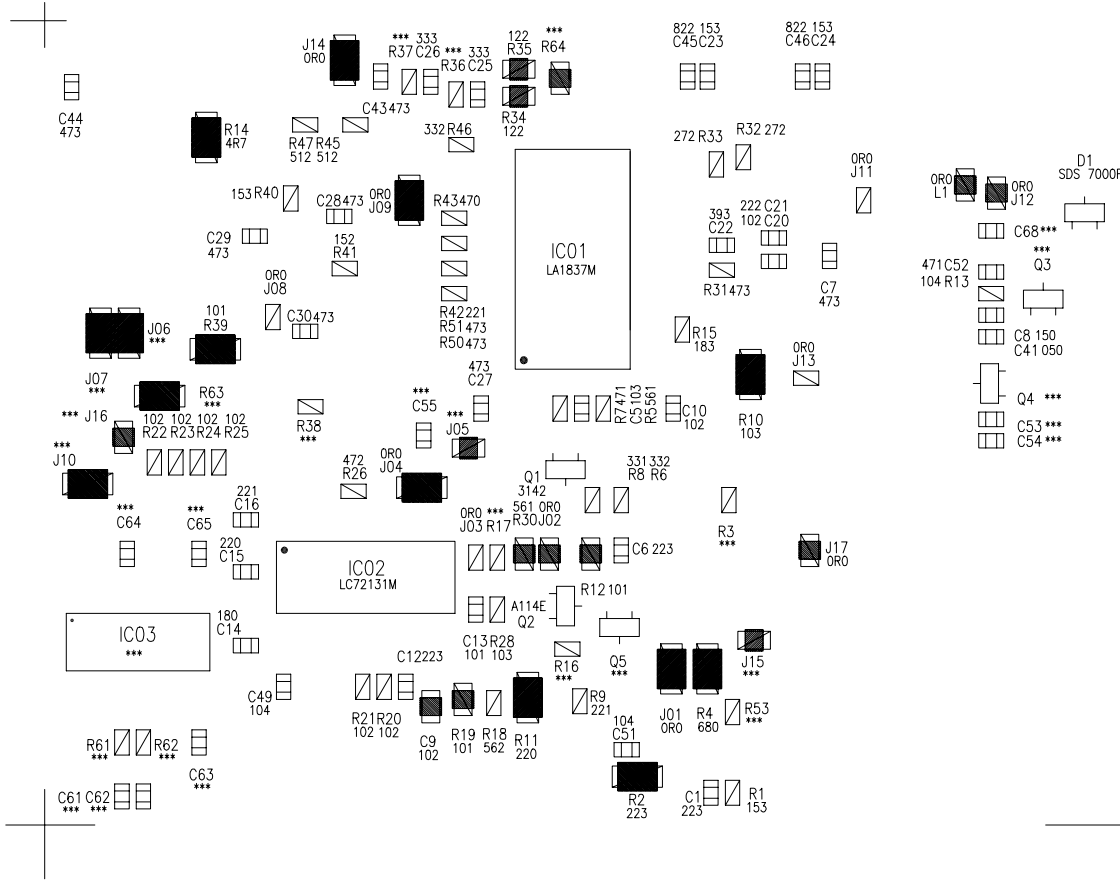
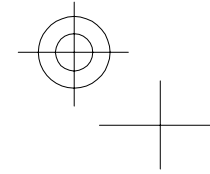

SC-031B-6

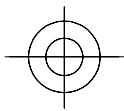

MODEL	KST-MV014MA0-80	SCALE	1 : 1
DRAWN NO	KETM095-8	VIEW	TOP VIEW

SAMLE : 10 PCS XPC 1.6t 2003. 01. 22  
 :  $\phi 0.8$  :  $\phi 0.9$  :  $\phi 0.95$  :  $\phi 1.0$  :  $\phi 1.1$  :  $\phi 1.2$  :  $\phi 0.8$

## MECHANICAL PART LIST

## DPR 1001 MECHANICAL PART LIST

A2AR L2000 A1A			BLOCK-MECHA		
NO	PART CODE	PART NAME	DESCRIPTION	UNIT	Q`TY
1	ACAC-01100-000	CORD-AC	10A/125V 2100mm CORE 270mm	PC	1
2	ACPC-00390-000	SMPS	KJP3011	PC	1
3	ACRC-00970-000	ASS'Y REMOCON	BE18A00	PC	1
4	AJAF-09720-013	FOOT(ASS'Y)	DPR 1001 ABS,POLYURETH	PC	4
5	AJAF-09730-013	KNOB-VOLUME(ASS'Y)	DPR 1001 ABS,AL,RUBBE	PC	1
6	ANTL-00130-E00	ANTENNA-LOOP AM	S0146BY-100	PC	1
7	ANTW-00060-152	FM WIRE ANTENNA	FM ANT(NTSC)-750HM,1500mm	PC	1
8	AXAG-14700-004	MAGNET		PC	1
9	LLA3-10211-E10	CARD CABLE	10P*210*C*1.25(0.1*0.8)	PC	1
10	LLA3-13060-E10	CARD CABLE	13P*60*C*1.25*(0.1*0.8)5*5	PC	1
11	LLA3-18080-E10	CARD CABLE	18P*80*C*1.25*(0.1*0.8)5*5	PC	1
12	LLA3-18121-E11	CARD CABLE	18P*120*C*1.25*(0.1*0.8)	PC	1
13	LLA3-28291-E10	CARD CABLE	28P*290*C*1.25*(0.1*0.8)	PC	1
14	LLA3-30080-E10	CARD CABLE	30P*80*C*1.25*(0.1*0.8)5*5	PC	1
15	MAAF-04090-012	WINDOW-FL	DPR 1001 ACRYL 3T M/R L	PC	1
16	MAAF-18660-014	LENS-OPTICAL	DPR 1001 PMMA	PC	4
17	MAAF-18670-014	LENS-POWER	DPR 1001 PMMA	PC	1
18	MAAF-18700-014	FILTER-FL	DPR 1001 PVC(RSM-05)94	PC	1
19	MAAF-18710-004	SHEET-LED(A)	PE(DRAFTING FILM)	PC	1
20	MAAF-18720-004	SHEET-LED(B)	PE(DRAFTING FILM)	PC	1
21	MAAF-18750-014	SHEET-DOOR	DPR 1001 PVC 0.25T	PC	1
22	MAAF-18930-004	INSULATION-SHEET	PVC T0.3	PC	1
23	MEAC-05361-003	HEATSINK-MAIN	A6063 T5	PC	1
24	MJAF-04070-012	DOOR-CAP	DPR 1001 ABS	PC	1
25	MJAF-06880-011	PANEL-FRONT	DPR 1001 HI-PS	PC	1
26	MJAF-09670-013	DOOR-BASE	DPR 1001 ABS	PC	1
27	MJAF-09680-013	FOOT	DPR 1001 ABS	PC	4
28	MJAF-09690-013	KNOB-FUNCTION(A)	DPR 1001 ABS	PC	1
29	MJAF-09700-013	KNOB-FUNCTION(B)	DPR 1001 ABS	PC	1
30	MJAF-09710-013	KNOB-VOLUME	DPR 1001 ABS	PC	1
31	MJAF-16060-014	KNOB-SPEAKER	F40-POWER ABS	PC	1
32	MJAF-18630-004	GUIDE-LED(A)	ABS 94V-0	PC	3
33	MJAF-18640-004	GUIDE-LED(B)	ABS 94V-0	PC	2
34	MJAF-18650-004	JOINT-STANDBY	ABS	PC	1
35	MJAF-18680-004	SUPPORT-PCB	ABS	PC	3
36	MJAG-00280-003	CORD-BUSH	NIFCO	PC	1
37	MJAG-04540-004	CABLE-TIE-L80		PC	12
38	MJAG-14740-004	SUPPORT	DASS35N TENSION TYPE	PC	1
39	MLAG-13850-034	BADGE-H/K	DPR 1001 AL	PC	1
40	MMAC-16400-004	SCREW-T/P-TOOTH	3X10 BLACK	PC	10
41	MMAC-16403-CR4	SCREW-T/P-TOOTH	3X8 CR	PC	8
42	MMAF-18690-014	RING-VOLUME	DPR 1001 AL 6063S T5	PC	1
43	MMSC-00900-004	AIR-STAPLER		PC	6
44	MMTC-00751-003	SCREW-TAPPING	BHW T2T 3x8 FE-ZY	PC	7
45	MPAC-05280-012	CHASSIS-BACK	DPR 1001 SECC T0.8	PC	1
46	MPAC-05320-002	CHASSIS-BOTTOM	SECC T1.0	PC	1
47	MPAC-05330-012	CHASSIS-TOP	DPR 1001 VCM T0.8	PC	1
48	MPAC-17470-004	SPRING-PLATE	PB T0.2	PC	2
49	MPAC-17490-004	BRACKET-MAGNET	SECC T0.8 (BLACK PLATING)	PC	1
50	MPAC-17690-004	EMI SHEET	70*40	PC	1
51	MRAG-13050-004	CUSHION-A	FELT 250x10x0.5	PC	2
52	MRAG-14551-004	CUSHION-FOOT(FRONT)	POLYURETHAN RUBBER T3.0	PC	2
53	MRAG-14552-004	CUSHION-FOOT(REAR)	POLYURETHAN RUBBER T3.0	PC	2
54	MRAG-14560-014	RUBBER-VOLUME	DPR 1001 CR	PC	1
55	MRAG-14710-004	CUSHION-SUPPORT	15X15XT8	PC	2
56	MRAG-14760-004	CUSHION SMPS	EVA 60*20*8T UL	PC	2
57	MXAG-14730-004	INSULATE-TUBE	POLYOLEFIN 0.4T	PC	1
58	TUMR-00140-00K	AM/FM TUNER MODULE	KST-MV014MA0-80	PC	1
59	UM08-51070-000	WIRE-ASS'Y	2457/1533#28 GRY-370 5P	PC	1
60	U345-6B332-450	WIRE-ASS'Y	1618#18 BLU-320 3P	PC	1
61	U345-6B353-450	WIRE-ASS'Y	1618#18 BLU-530 3P	PC	1
62	U449-61225-490	WIRE-ASS'Y	1007#16 BLU-250 4P	PC	1
63	XSTB-30080-ZB4	SCREW-TAPPING	BHT2T 3x8 FE-ZB	PC	2
64	XSTB-30080-ZY4	SCREW-TAPPING	BHT2T 3x8 FE-ZY	PC	14



## MECHANICAL PART LIST

65	XSTB-30100-ZB4	SCREW-TAPPING	BHT2T 3x10 FE-ZB	PC	32
66	XSTB-30100-ZY4	SCREW-TAPPING	BHT2T 3x10 FE-ZY	PC	22
67	XSTF-30080-ZY4	SCREW-TAPPING	FHT2T 3x8 FE-ZY	PC	4
68	XSTS-30080-ZY4	SCREW-TAPPING	PHWT2T 3x8 FE-ZY	PC	6
69	YGAP-16650-014	BOX-GIFT	DPR 1001 DW2	PC	1
70	YSAP-12290-002	CUSHION-L/R	EPS	PC	2
71	YVAP-01862-014	POLY-BAG-I(G)		PC	1
72	YVAP-13320-014	TOILON-SHEET	750x1200,0.5t	PC	1
73	MRAG-14770-004	CUSHION FELT	FELT 20*8*0.5T	PC	1
74	MRAG-14780-004	CUSHION(A)	EVA 60*10*8T UL	PC	1
75	MRAG-14790-004	CUSHION(B)	EVA 36*20*8T UL	PC	1
76	MMTC-00752-003	SCREW-TAPPING	BHW T2T 3x10 FE-ZY	PC	3
77	MMTC-00754-003	SCREW-TAPPING	BHW T2T 3x14 FE-ZY	PC	3
78	MMAC-15650-004	SCREW-RADIATOR		PC	3
79	ACRC-01000-000	ZONE II REMOCON	HG18B	PC	1
80	MPAC-17710-004	EMI SHEET-A	80*30 +	PC	1
81	MPAC-17720-004	EMI SHEET-B	40*20	PC	1
82	MRAG-14800-004	PVC SHEET	PVC 0.3T UL	PC	1
83	MRAG-13840-004	CUSHION-REMOTE	EVA T=11.0	PC	2
84	MPAC-17730-004	CLAMP WIRE		PC	4

## A2AR L2000 AYA

NO	PART CODE	PART NAME	DESCRIPTION	UNIT	Q`TY
1	YBAP-14361-014	SERIAL No.LABEL	30X8	PC	1
2	YBAP-14900-014	LABEL-BAR CODE	ART PAPER TO.1	PC	2
3	YBAP-14910-014	LABEL-PRODUCTION	ART PAPER TO.1	PC	1
4	YBAP-14920-014	LABEL-FUSE	ART PAPER TO.1	PC	1
5	YBAP-14930-134	LABEL-UJC	ART PAPER TO.1	PC	2
6	YBAP-15581-054	LABEL-CODE39		PC	3
7	YBAP-15670-014	LABEL-WINDOW	ART PAPER 01	PC	1
8	YBAP-16930-014	LABEL-C/CAUTION	DPR 1001 132X32 R=1.5	PC	1
9	YBAP-16940-014	LABEL-DOLBY	DPR 1001 66X68 R=1.5	PC	1
10	YBAP-16960-014	WARRANTY-CARD	210X297	PC	1
11	YBAP-16970-014	SAFETY-CARD	210X297	PC	1
12	YBAP-17020-014	QUICK START GUIDE	DPR 1001	PC	1
13	YIAR-L2000-01A	INST-MANUAL		PC	1
14	YBAP-17090-ZZ4	OM INSERT SHEET		PC	1

## BLOCK-PRINT

## A2AR L2000 AZA

NO	PART CODE	PART NAME	DESCRIPTION	UNIT	Q`TY
1	ZGSI-01000-9PN	GREASE-SILICON	G-746	g	1
2	ZTOP-00701-50C	TAPE-OPP		m	2.133
3	ZTWF-01200-039	TAPE-DOUBLE FACE	TESA 4968 W =3.0 t=0.32	m	0.2
4	ZBNG-00700-4ZL	BOND-ADHESIVE	#575	g	0.5
5	ZBNG-01300-5ZL	LOCKER-SCREW	#1401B	g	0.1
6	ZSBR-00010-060	SOLDER-BAR	SN60	g	15
7	ZSWR-00010-F60	SOLDER-WIRE	D1.0 SN60	g	15
8	ZZFX-00010-000	FLUX	ROSIN	g	7
9	ZZTH-00010-000	DILUENT	ROSIN	g	2

## BLOCK-SUB

## ELECTRICAL PART LIST

LOCNUM	FRONT (VFD) SONITM	MATDES	MATSPC
C117	CCAT-E222M-AAY	CAPACITOR CERAMIC	2200PF M 16V Y5R T
C118	CCAT-E222M-AAY	CAPACITOR CERAMIC	2200PF M 16V Y5R T
C114	CCAT-J104Z-AAF	CAPACITOR CERAMIC	0.1uF Z 50V F T
C115	CCAT-J104Z-AAF	CAPACITOR CERAMIC	0.1uF Z 50V F T
C111	CCMB-J101J-0BZ	CAPACITOR CHIP/MULT	100PF J 50V Z B
C112	CCMB-J101J-0BZ	CAPACITOR CHIP/MULT	100PF J 50V Z B
C113	CCMB-J101J-0BZ	CAPACITOR CHIP/MULT	100PF J 50V Z B
C106	CCMB-J104Z-0BF	CAPACITOR CHIP/MULT	0.1uF Z 50V F B
C108	CCMB-J104Z-0BF	CAPACITOR CHIP/MULT	0.1uF Z 50V F B
C120	CCMB-J104Z-0BF	CAPACITOR CHIP/MULT	0.1uF Z 50V F B
C124	CCMB-J104Z-0BF	CAPACITOR CHIP/MULT	0.1uF Z 50V F B
C125	CCMB-J104Z-0BF	CAPACITOR CHIP/MULT	0.1uF Z 50V F B
C101	CCMB-J220J-0BC	CAPACITOR CHIP/MULT	22PF J 50V C B
C102	CCMB-J220J-0BC	CAPACITOR CHIP/MULT	22PF J 50V C B
C109	CCMB-J821K-0BB	CAPACITOR CHIP/MULT	820PF K 50V X7R B
C110	CCMB-J821K-0BB	CAPACITOR CHIP/MULT	820PF K 50V X7R B
C105	CEET-D221M-DI0	CAPACITOR E/ALUMINUM	220uF M 10V 6.3x11 T
C107	CEET-D221M-DI0	CAPACITOR E/ALUMINUM	220uF M 10V 6.3x11 T
C121	CEET-F470M-DE0	CAPACITOR E/ALUMINUM	47uF/25V (6.3x7)
C122	CEET-F470M-DE0	CAPACITOR E/ALUMINUM	47uF/25V (6.3x7)
C123	CEET-F470M-DE0	CAPACITOR E/ALUMINUM	47uF/25V (6.3x7)
C103	CEET-J470M-DI0	CAPACITOR E/ALUMINUM	47uF M 50V 6.3x11 T
C104	CEET-J470M-DI0	CAPACITOR E/ALUMINUM	47uF M 50V 6.3x11 T
D101	DDTS-00070-S00	DIODE-SI	1SS133 (40V 0.11A) DO-40 T
D102	DDTS-00070-S00	DIODE-SI	1SS133 (40V 0.11A) DO-40 T
ZD101	DDTZ-G075B-S00	DIODE ZENER	MTZ7.5B 7.07-7.45 D040 T
VFD101	DPFL-00970-00P	DISPLAY-FLUORSCENT	CM2052G
LD101	DPLE-01050-000	DISPLAY-LED	SY3511-E(F4T)
LD102	DPLE-01050-000	DISPLAY-LED	SY3511-E(F4T)
LD103	DPLE-01050-000	DISPLAY-LED	SY3511-E(F4T)
LD104	DPLE-01050-000	DISPLAY-LED	SY3511-E(F4T)
LD105	DPLE-01050-000	DISPLAY-LED	SY3511-E(F4T)
LD106	DPLE-01050-000	DISPLAY-LED	SY3511-E(F4T)
LD107	DPLE-01050-000	DISPLAY-LED	SY3511-E(F4T)
LD108	DPLE-01050-000	DISPLAY-LED	SY3511-E(F4T)
LD109	DPLE-01050-000	DISPLAY-LED	SY3511-E(F4T)
LD110	DPLE-01050-000	DISPLAY-LED	SY3511-E(F4T)
LD111	DPLE-01050-000	DISPLAY-LED	SY3511-E(F4T)
LD112	DPLE-01050-000	DISPLAY-LED	SY3511-E(F4T)
LD113	DPLE-01050-000	DISPLAY-LED	SY3511-E(F4T)
LD114	DPLE-01050-000	DISPLAY-LED	SY3511-E(F4T)
LD115	DPLE-01050-000	DISPLAY-LED	SY3511-E(F4T)
LD116	DPLT-01060-000	LED LAMP	SY3511(F4T)
LD117	DPLT-01060-000	LED LAMP	SY3511(F4T)
LD118	DPLT-01060-000	LED LAMP	SY3511(F4T)
LD119	DPLT-01060-000	LED LAMP	SY3511(F4T)
LD120	DPLT-01060-000	LED LAMP	SY3511(F4T)
LD121	DPLT-01060-000	LED LAMP	SY3511(F4T)
LD122	DPLT-01060-000	LED LAMP	SY3511(F4T)
LD123	DPLT-01060-000	LED LAMP	SY3511(F4T)
LD124	DPLT-01060-000	LED LAMP	SY3511(F4T)
LD125	DPLT-01060-000	LED LAMP	SY3511(F4T)
IC103	ICLN-04720-SB0	IC 8BIT SHIF/STORE	BU4094BC SOP16
IC101	ICLN-04820-S10	IC VFD DRIVER	LC75725E QIP64
IC102	ICLN-04820-S10	IC VFD DRIVER	LC75725E QIP64
	KI0T-4330K-003	COIL-INDUCTOR	33uH K L5 2.3x3.4 LAL02
	KNCW-00160-6S9	CONNECTOR-WAFER	53015-0610 2mm-WHT
CN102	KNCW-00240-3T9	CONNECTOR-WAFER	53014-03 2.0mm WHT
CN101	KNCW-00760-SS0	CONNECTOR-WAFER	8370-287 1.25mm SIDE 28P
CN104	KNCW-06880-13T	CONNECTOR-WAFER	JE117-C13G-13
	MJAF-04080-002	GUIDE-FL	ABS 94V-0
	PCSR-05940-11B	PCB-SINGLE	A1R-594
C116	RCFT-E101J-000	RESISTOR-CARBON FILM	100ohm 1/5W 5% T
R151	RCFT-E101J-000	RESISTOR-CARBON FILM	100ohm 1/5W 5% T
R111	RCFT-E103J-000	RESISTOR-CARBON FILM	10Kohm 1/5W 5% T
R153	RCFT-E472J-000	RESISTOR-CARBON FILM	4.7Kohm 1/5W 5% T
R103	RCFT-F221J-010	RESISTOR-CARBON FILM	220ohm 1/4W 5% T
R104	RCFT-F221J-010	RESISTOR-CARBON FILM	220ohm 1/4W 5% T
R154	RCPB-B101J-21C	RESISTOR-CHIP C/FILM	100ohm 1/10W 5% B
R155	RCPB-B101J-21C	RESISTOR-CHIP C/FILM	100ohm 1/10W 5% B

## ELECTRICAL PART LIST

R113	RCPB-B102J-21C	RESISTOR-CHIP C/FILM	1Kohm	1/10W	5%	B
R114	RCPB-B102J-21C	RESISTOR-CHIP C/FILM	1Kohm	1/10W	5%	B
R115	RCPB-B102J-21C	RESISTOR-CHIP C/FILM	1Kohm	1/10W	5%	B
R142	RCPB-B102J-21C	RESISTOR-CHIP C/FILM	1Kohm	1/10W	5%	B
R141	RCPB-B103J-21C	RESISTOR-CHIP C/FILM	10Kohm	1/10W	5%	B
R149	RCPB-B103J-21C	RESISTOR-CHIP C/FILM	10Kohm	1/10W	5%	B
R150	RCPB-B103J-21C	RESISTOR-CHIP C/FILM	10Kohm	1/10W	5%	B
R156	RCPB-B104J-21C	RESISTOR-CHIP C/FILM	100Kohm	1/10W	5%	B
R157	RCPB-B104J-21C	RESISTOR-CHIP C/FILM	100Kohm	1/10W	5%	B
	RCPB-B105J-21C	RESISTOR-CHIP C/FILM	1Mohm	1/10W	5%	B
R148	RCPB-B123J-21C	RESISTOR-CHIP C/FILM	12Kohm	1/10W	5%	B
R143	RCPB-B152J-21C	RESISTOR-CHIP C/FILM	1.5Kohm	1/10W	5%	B
R144	RCPB-B222J-21C	RESISTOR-CHIP C/FILM	2.2Kohm	1/10W	5%	B
R105	RCPB-B330J-21C	RESISTOR-CHIP C/FILM	33ohm	1/10W	5%	B
R106	RCPB-B330J-21C	RESISTOR-CHIP C/FILM	33ohm	1/10W	5%	B
R107	RCPB-B330J-21C	RESISTOR-CHIP C/FILM	33ohm	1/10W	5%	B
R108	RCPB-B330J-21C	RESISTOR-CHIP C/FILM	33ohm	1/10W	5%	B
R109	RCPB-B330J-21C	RESISTOR-CHIP C/FILM	33ohm	1/10W	5%	B
R110	RCPB-B330J-21C	RESISTOR-CHIP C/FILM	33ohm	1/10W	5%	B
R116	RCPB-B331J-21C	RESISTOR-CHIP C/FILM	330ohm	1/10W	5%	B
R117	RCPB-B331J-21C	RESISTOR-CHIP C/FILM	330ohm	1/10W	5%	B
R118	RCPB-B331J-21C	RESISTOR-CHIP C/FILM	330ohm	1/10W	5%	B
R119	RCPB-B331J-21C	RESISTOR-CHIP C/FILM	330ohm	1/10W	5%	B
R120	RCPB-B331J-21C	RESISTOR-CHIP C/FILM	330ohm	1/10W	5%	B
R121	RCPB-B331J-21C	RESISTOR-CHIP C/FILM	330ohm	1/10W	5%	B
R122	RCPB-B331J-21C	RESISTOR-CHIP C/FILM	330ohm	1/10W	5%	B
R123	RCPB-B331J-21C	RESISTOR-CHIP C/FILM	330ohm	1/10W	5%	B
R124	RCPB-B331J-21C	RESISTOR-CHIP C/FILM	330ohm	1/10W	5%	B
R125	RCPB-B331J-21C	RESISTOR-CHIP C/FILM	330ohm	1/10W	5%	B
R126	RCPB-B331J-21C	RESISTOR-CHIP C/FILM	330ohm	1/10W	5%	B
R127	RCPB-B331J-21C	RESISTOR-CHIP C/FILM	330ohm	1/10W	5%	B
R128	RCPB-B331J-21C	RESISTOR-CHIP C/FILM	330ohm	1/10W	5%	B
R129	RCPB-B331J-21C	RESISTOR-CHIP C/FILM	330ohm	1/10W	5%	B
R130	RCPB-B331J-21C	RESISTOR-CHIP C/FILM	330ohm	1/10W	5%	B
R131	RCPB-B331J-21C	RESISTOR-CHIP C/FILM	330ohm	1/10W	5%	B
R132	RCPB-B331J-21C	RESISTOR-CHIP C/FILM	330ohm	1/10W	5%	B
R133	RCPB-B331J-21C	RESISTOR-CHIP C/FILM	330ohm	1/10W	5%	B
R134	RCPB-B331J-21C	RESISTOR-CHIP C/FILM	330ohm	1/10W	5%	B
R135	RCPB-B331J-21C	RESISTOR-CHIP C/FILM	330ohm	1/10W	5%	B
R136	RCPB-B331J-21C	RESISTOR-CHIP C/FILM	330ohm	1/10W	5%	B
R137	RCPB-B331J-21C	RESISTOR-CHIP C/FILM	330ohm	1/10W	5%	B
R138	RCPB-B331J-21C	RESISTOR-CHIP C/FILM	330ohm	1/10W	5%	B
R139	RCPB-B331J-21C	RESISTOR-CHIP C/FILM	330ohm	1/10W	5%	B
R140	RCPB-B331J-21C	RESISTOR-CHIP C/FILM	330ohm	1/10W	5%	B
R145	RCPB-B332J-21C	RESISTOR-CHIP C/FILM	3.3Kohm	1/10W	5%	B
R146	RCPB-B472J-21C	RESISTOR-CHIP C/FILM	4.7Kohm	1/10W	5%	B
R101	RCPB-B562J-21C	RESISTOR-CHIP C/FILM	5.6Kohm	1/10W	5%	B
R102	RCPB-B562J-21C	RESISTOR-CHIP C/FILM	5.6Kohm	1/10W	5%	B
R147	RCPB-B562J-21C	RESISTOR-CHIP C/FILM	5.6Kohm	1/10W	5%	B
IC104	SKMJ-00370-000	RECEIVING MODULE	VSR5A/5B			
JK101	SKPH-00293-66W	SOCKET-PHONE	HTJ064-05BG	GOLD		
SW101	SWTA-00650-000	SWITCH TACT	SKQNAED010			
SW102	SWTA-00650-000	SWITCH TACT	SKQNAED010			
SW103	SWTA-00650-000	SWITCH TACT	SKQNAED010			
SW104	SWTA-00650-000	SWITCH TACT	SKQNAED010			
SW105	SWTA-00650-000	SWITCH TACT	SKQNAED010			
SW106	SWTA-00650-000	SWITCH TACT	SKQNAED010			
SW107	SWTA-00650-000	SWITCH TACT	SKQNAED010			
Q101	TRTC-02050-SD0	TRANSISTOR N-H FREQ	KRC120M	W/RESIST	TO92M	
Q102	TRTC-02050-SD0	TRANSISTOR N-H FREQ	KRC120M	W/RESIST	TO92M	
Q103	TRTC-02050-SD0	TRANSISTOR N-H FREQ	KRC120M	W/RESIST	TO92M	
Q104	TRTC-02050-SD0	TRANSISTOR N-H FREQ	KRC120M	W/RESIST	TO92M	
Q105	TRTC-02050-SD0	TRANSISTOR N-H FREQ	KRC120M	W/RESIST	TO92M	
Q106	TRTC-02050-SD0	TRANSISTOR N-H FREQ	KRC120M	W/RESIST	TO92M	
Q107	TRTC-02050-SD0	TRANSISTOR N-H FREQ	KRC120M	W/RESIST	TO92M	
Q108	TRTC-02050-SD0	TRANSISTOR N-H FREQ	KRC120M	W/RESIST	TO92M	
Q109	TRTC-02050-SD0	TRANSISTOR N-H FREQ	KRC120M	W/RESIST	TO92M	
Q110	TRTC-02050-SD0	TRANSISTOR N-H FREQ	KRC120M	W/RESIST	TO92M	
	UMT1-11072-000	WIRE-ASS'Y	MASH WIRE	0.12/6/16	120	
VR101	VRAE-E0450-000	VR-ENCODER	EC16B24S00B2-ZZZ			

## ELECTRICAL PART LIST

LOCNUM	SONITM	MATDES	MATSPC
	FRONT (KEY)		
	LOCNUM	SONITM	MATDES
	SONITM	MATDES	MATSPC
C216	CACS-S472M-200	CAPACITOR AC	KH DE1310E 472M 250V P10mm
C210	CCMB-J101J-0BZ	CAPACITOR CHIP/MULT	100PF J 50V Z B
C211	CCMB-J101J-0BZ	CAPACITOR CHIP/MULT	100PF J 50V Z B
C212	CCMB-J101J-0BZ	CAPACITOR CHIP/MULT	100PF J 50V Z B
C213	CCMB-J101J-0BZ	CAPACITOR CHIP/MULT	100PF J 50V Z B
C206	CCMB-J104Z-0BF	CAPACITOR CHIP/MULT	0.1uF Z 50V F B
C208	CCMB-J104Z-0BF	CAPACITOR CHIP/MULT	0.1uF Z 50V F B
C209	CCMB-J104Z-0BF	CAPACITOR CHIP/MULT	0.1uF Z 50V F B
C218	CCMB-J104Z-0BF	CAPACITOR CHIP/MULT	0.1uF Z 50V F B
C220	CCMB-J104Z-0BF	CAPACITOR CHIP/MULT	0.1uF Z 50V F B
C207	CCMB-J561J-0BZ	CAPACITOR CHIP/MULT	560PF J 50V Z B
C203	CEET-D221M-DI0	CAPACITOR E/ALUMINUM	220uF M 10V 6.3x11 T
C204	CEET-F101M-DI0	CAPACITOR E/ALUMINUM	100uF M 25V 6.3x11 T
C201	CEET-F470M-DE0	CAPACITOR E/ALUMINUM	47uF/25V (6.3x7)
C219	CEET-F470M-DE0	CAPACITOR E/ALUMINUM	47uF/25V (6.3x7)
C221	CEET-F470M-DE0	CAPACITOR E/ALUMINUM	47uF/25V (6.3x7)
LD238	DPLE-00280-RG0	DISPLAY-LED	SAM5270 RED/GRN
LD239	DPLE-00990-RG0	DISPLAY LED	SAM3270
LD240	DPLE-00990-RG0	DISPLAY LED	SAM3270
LD201	DPLE-01050-000	DISPLAY-LED	SY3511-E(F4T)
LD202	DPLE-01050-000	DISPLAY-LED	SY3511-E(F4T)
LD203	DPLE-01050-000	DISPLAY-LED	SY3511-E(F4T)
LD204	DPLE-01050-000	DISPLAY-LED	SY3511-E(F4T)
LD205	DPLE-01050-000	DISPLAY-LED	SY3511-E(F4T)
LD206	DPLE-01050-000	DISPLAY-LED	SY3511-E(F4T)
LD207	DPLE-01050-000	DISPLAY-LED	SY3511-E(F4T)
LD208	DPLE-01050-000	DISPLAY-LED	SY3511-E(F4T)
LD209	DPLE-01050-000	DISPLAY-LED	SY3511-E(F4T)
LD210	DPLE-01050-000	DISPLAY-LED	SY3511-E(F4T)
LD211	DPLE-01050-000	DISPLAY-LED	SY3511-E(F4T)
LD212	DPLE-01050-000	DISPLAY-LED	SY3511-E(F4T)
LD213	DPLE-01050-000	DISPLAY-LED	SY3511-E(F4T)
LD214	DPLE-01050-000	DISPLAY-LED	SY3511-E(F4T)
LD215	DPLE-01050-000	DISPLAY-LED	SY3511-E(F4T)
LD216	DPLE-01050-000	DISPLAY-LED	SY3511-E(F4T)
LD217	DPLE-01050-000	DISPLAY-LED	SY3511-E(F4T)
LD218	DPLE-01050-000	DISPLAY-LED	SY3511-E(F4T)
LD219	DPLE-01050-000	DISPLAY-LED	SY3511-E(F4T)
LD220	DPLE-01050-000	DISPLAY-LED	SY3511-E(F4T)
LD221	DPLE-01050-000	DISPLAY-LED	SY3511-E(F4T)
LD222	DPLE-01050-000	DISPLAY-LED	SY3511-E(F4T)
LD223	DPLE-01050-000	DISPLAY-LED	SY3511-E(F4T)
LD224	DPLT-01060-000	LED LAMP	SY3511(F4T)
LD225	DPLT-01060-000	LED LAMP	SY3511(F4T)
LD226	DPLT-01060-000	LED LAMP	SY3511(F4T)
LD227	DPLT-01060-000	LED LAMP	SY3511(F4T)
LD228	DPLT-01060-000	LED LAMP	SY3511(F4T)
LD229	DPLT-01060-000	LED LAMP	SY3511(F4T)
LD230	DPLT-01060-000	LED LAMP	SY3511(F4T)
LD231	DPLT-01060-000	LED LAMP	SY3511(F4T)
LD232	DPLT-01060-000	LED LAMP	SY3511(F4T)
LD233	DPLT-01060-000	LED LAMP	SY3511(F4T)
LD234	DPLT-01060-000	LED LAMP	SY3511(F4T)
LD235	DPLT-01060-000	LED LAMP	SY3511(F4T)
LD236	DPLT-01060-000	LED LAMP	SY3511(F4T)
LD237	DPLT-01060-000	LED LAMP	SY3511(F4T)
IC203	ICHY-00350-SB0	IC REMOTE CONTROL	RPM6938-V4
IC201	ICLN-04720-SB0	IC 8BIT SHIF/STORE	BU4094BC SOP16
IC202	ICLN-04720-SB0	IC 8BIT SHIF/STORE	BU4094BC SOP16
CN204	KNCW-00160-2S9	CONNECTOR-WAFER	53015-0210 2mm-WHT
CN203	KNCW-00760-AS0	CONNECTOR-WAFER	8370-107 1.25mm SIDE 10P
CN205	KNCW-00980-2S9	CONNECTOR-WAFER	JE202A-2T-2P
CN201	KNCW-06910-013	DIP SOCKET	JE600A-13
	MJAF-18620-004	GUIDE-REMOTE	ABS 94V-0
	PCSR-06030-11B	PCB-SINGLE	A1R-603
R262	RCPB-B101J-21C	RESISTOR-CHIP C/FILM	100ohm 1/10W 5% B
R263	RCPB-B101J-21C	RESISTOR-CHIP C/FILM	100ohm 1/10W 5% B
R264	RCPB-B101J-21C	RESISTOR-CHIP C/FILM	100ohm 1/10W 5% B
R265	RCPB-B101J-21C	RESISTOR-CHIP C/FILM	100ohm 1/10W 5% B



## ELECTRICAL PART LIST

JW18	RJWT-00000-AA0	RESISTOR-JUMPER WIRE	60mm-TX123 F
JW19	RJWT-00000-AA0	RESISTOR-JUMPER WIRE	60mm-TX123 F
JW2	RJWT-00000-AA0	RESISTOR-JUMPER WIRE	60mm-TX123 F
JW20	RJWT-00000-AA0	RESISTOR-JUMPER WIRE	60mm-TX123 F
JW21	RJWT-00000-AA0	RESISTOR-JUMPER WIRE	60mm-TX123 F
JW22	RJWT-00000-AA0	RESISTOR-JUMPER WIRE	60mm-TX123 F
JW23	RJWT-00000-AA0	RESISTOR-JUMPER WIRE	60mm-TX123 F
JW24	RJWT-00000-AA0	RESISTOR-JUMPER WIRE	60mm-TX123 F
JW25	RJWT-00000-AA0	RESISTOR-JUMPER WIRE	60mm-TX123 F
JW26	RJWT-00000-AA0	RESISTOR-JUMPER WIRE	60mm-TX123 F
JW27	RJWT-00000-AA0	RESISTOR-JUMPER WIRE	60mm-TX123 F
JW28	RJWT-00000-AA0	RESISTOR-JUMPER WIRE	60mm-TX123 F
JW29	RJWT-00000-AA0	RESISTOR-JUMPER WIRE	60mm-TX123 F
JW3	RJWT-00000-AA0	RESISTOR-JUMPER WIRE	60mm-TX123 F
JW30	RJWT-00000-AA0	RESISTOR-JUMPER WIRE	60mm-TX123 F
JW31	RJWT-00000-AA0	RESISTOR-JUMPER WIRE	60mm-TX123 F
JW32	RJWT-00000-AA0	RESISTOR-JUMPER WIRE	60mm-TX123 F
JW33	RJWT-00000-AA0	RESISTOR-JUMPER WIRE	60mm-TX123 F
JW35	RJWT-00000-AA0	RESISTOR-JUMPER WIRE	60mm-TX123 F
JW36	RJWT-00000-AA0	RESISTOR-JUMPER WIRE	60mm-TX123 F
JW37	RJWT-00000-AA0	RESISTOR-JUMPER WIRE	60mm-TX123 F
JW38	RJWT-00000-AA0	RESISTOR-JUMPER WIRE	60mm-TX123 F
JW39	RJWT-00000-AA0	RESISTOR-JUMPER WIRE	60mm-TX123 F
JW4	RJWT-00000-AA0	RESISTOR-JUMPER WIRE	60mm-TX123 F
JW40	RJWT-00000-AA0	RESISTOR-JUMPER WIRE	60mm-TX123 F
JW41	RJWT-00000-AA0	RESISTOR-JUMPER WIRE	60mm-TX123 F
JW42	RJWT-00000-AA0	RESISTOR-JUMPER WIRE	60mm-TX123 F
JW43	RJWT-00000-AA0	RESISTOR-JUMPER WIRE	60mm-TX123 F
JW44	RJWT-00000-AA0	RESISTOR-JUMPER WIRE	60mm-TX123 F
JW47	RJWT-00000-AA0	RESISTOR-JUMPER WIRE	60mm-TX123 F
JW49	RJWT-00000-AA0	RESISTOR-JUMPER WIRE	60mm-TX123 F
JW5	RJWT-00000-AA0	RESISTOR-JUMPER WIRE	60mm-TX123 F
JW50	RJWT-00000-AA0	RESISTOR-JUMPER WIRE	60mm-TX123 F
JW51	RJWT-00000-AA0	RESISTOR-JUMPER WIRE	60mm-TX123 F
JW6	RJWT-00000-AA0	RESISTOR-JUMPER WIRE	60mm-TX123 F
JW7	RJWT-00000-AA0	RESISTOR-JUMPER WIRE	60mm-TX123 F
JW8	RJWT-00000-AA0	RESISTOR-JUMPER WIRE	60mm-TX123 F
JW9	RJWT-00000-AA0	RESISTOR-JUMPER WIRE	60mm-TX123 F
JK202	SKDN-00141-010	S-CONNECTOR (1P)	C40160261G
JK201	SKRC-00380-031	SOCKET-RCA	JK0300081G
JK203	SKRC-01360-01P	RCA JACK	JK010053HG
SW209	SWPU-00680-000	SWITCH POWER	SDKVB1040X 3.2HOLE
SW201	SWTA-00650-000	SWITCH TACT	SKQNAED010
SW202	SWTA-00650-000	SWITCH TACT	SKQNAED010
SW203	SWTA-00650-000	SWITCH TACT	SKQNAED010
SW204	SWTA-00650-000	SWITCH TACT	SKQNAED010
SW205	SWTA-00650-000	SWITCH TACT	SKQNAED010
SW206	SWTA-00650-000	SWITCH TACT	SKQNAED010
SW207	SWTA-00650-000	SWITCH TACT	SKQNAED010
SW208	SWTA-00650-000	SWITCH TACT	SKQNAED010
Q209	TRTC-01700-SD0	TRANSISTOR N-H FREQ	KRC107M W/RESIST TO92M
Q210	TRTC-01700-SD0	TRANSISTOR N-H FREQ	KRC107M W/RESIST TO92M
Q217	TRTC-01700-SD0	TRANSISTOR N-H FREQ	KRC107M W/RESIST TO92M
Q218	TRTC-01700-SD0	TRANSISTOR N-H FREQ	KRC107M W/RESIST TO92M
Q219	TRTC-01700-SD0	TRANSISTOR N-H FREQ	KRC107M W/RESIST TO92M
Q220	TRTC-01700-SD0	TRANSISTOR N-H FREQ	KRC107M W/RESIST TO92M
Q201	TRTC-02050-SD0	TRANSISTOR N-H FREQ	KRC120M W/RESIST TO92M
Q202	TRTC-02050-SD0	TRANSISTOR N-H FREQ	KRC120M W/RESIST TO92M
Q203	TRTC-02050-SD0	TRANSISTOR N-H FREQ	KRC120M W/RESIST TO92M
Q204	TRTC-02050-SD0	TRANSISTOR N-H FREQ	KRC120M W/RESIST TO92M
Q205	TRTC-02050-SD0	TRANSISTOR N-H FREQ	KRC120M W/RESIST TO92M
Q206	TRTC-02050-SD0	TRANSISTOR N-H FREQ	KRC120M W/RESIST TO92M
Q207	TRTC-02050-SD0	TRANSISTOR N-H FREQ	KRC120M W/RESIST TO92M
Q208	TRTC-02050-SD0	TRANSISTOR N-H FREQ	KRC120M W/RESIST TO92M
Q211	TRTC-02050-SD0	TRANSISTOR N-H FREQ	KRC120M W/RESIST TO92M
Q212	TRTC-02050-SD0	TRANSISTOR N-H FREQ	KRC120M W/RESIST TO92M
Q213	TRTC-02050-SD0	TRANSISTOR N-H FREQ	KRC120M W/RESIST TO92M
Q214	TRTC-02050-SD0	TRANSISTOR N-H FREQ	KRC120M W/RESIST TO92M
Q215	TRTC-02050-SD0	TRANSISTOR N-H FREQ	KRC120M W/RESIST TO92M
Q216	TRTC-02050-SD0	TRANSISTOR N-H FREQ	KRC120M W/RESIST TO92M
U408	80834-250	WIRE-ASS'Y	1533#28 GRY-340 4P



## ELECTRICAL PART LIST

C775	CCMB-J104Z-0BF	CAPACITOR CHIP/MULT	0.1uF	Z 50V	F B	
C777	CCMB-J104Z-0BF	CAPACITOR CHIP/MULT	0.1uF	Z 50V	F B	
C778	CCMB-J104Z-0BF	CAPACITOR CHIP/MULT	0.1uF	Z 50V	F B	
C779	CCMB-J104Z-0BF	CAPACITOR CHIP/MULT	0.1uF	Z 50V	F B	
C781	CCMB-J104Z-0BF	CAPACITOR CHIP/MULT	0.1uF	Z 50V	F B	
C784	CCMB-J104Z-0BF	CAPACITOR CHIP/MULT	0.1uF	Z 50V	F B	
C785	CCMB-J104Z-0BF	CAPACITOR CHIP/MULT	0.1uF	Z 50V	F B	
C669	CCMB-J151J-0BC	CAPACITOR CHIP/MULT	150PF	J 50V	C B	
C670	CCMB-J151J-0BC	CAPACITOR CHIP/MULT	150PF	J 50V	C B	
C786	CCMB-J152J-0BZ	CAPACITOR CHIP/MULT	1500PF	J 50V	Z B	
C787	CCMB-J152J-0BZ	CAPACITOR CHIP/MULT	1500PF	J 50V	Z B	
C632	CCMB-J330J-0BC	CAPACITOR CHIP/MULT	33PF	J 50V	C B	
C633	CCMB-J330J-0BC	CAPACITOR CHIP/MULT	33PF	J 50V	C B	
C636	CCMB-J560J-0BZ	CAPACITOR CHIP/MULT	56PF	J 50V	Z B	
C638	CCMB-J560J-0BZ	CAPACITOR CHIP/MULT	56PF	J 50V	Z B	
C640	CCMB-J560J-0BZ	CAPACITOR CHIP/MULT	56PF	J 50V	Z B	
C642	CCMB-J560J-0BZ	CAPACITOR CHIP/MULT	56PF	J 50V	Z B	
C644	CCMB-J560J-0BZ	CAPACITOR CHIP/MULT	56PF	J 50V	Z B	
C659	CCMB-J560J-0BZ	CAPACITOR CHIP/MULT	56PF	J 50V	Z B	
C660	CCMB-J560J-0BZ	CAPACITOR CHIP/MULT	56PF	J 50V	Z B	
C661	CCMB-J560J-0BZ	CAPACITOR CHIP/MULT	56PF	J 50V	Z B	
C665	CCMB-J560J-0BZ	CAPACITOR CHIP/MULT	56PF	J 50V	Z B	
C667	CCMB-J560J-0BZ	CAPACITOR CHIP/MULT	56PF	J 50V	Z B	
C668	CCMB-J560J-0BZ	CAPACITOR CHIP/MULT	56PF	J 50V	Z B	
C682	CCMB-J560J-0BZ	CAPACITOR CHIP/MULT	56PF	J 50V	Z B	
C683	CCMB-J560J-0BZ	CAPACITOR CHIP/MULT	56PF	J 50V	Z B	
C687	CCMB-J560J-0BZ	CAPACITOR CHIP/MULT	56PF	J 50V	Z B	
C796	CCMB-J560J-0BZ	CAPACITOR CHIP/MULT	56PF	J 50V	Z B	
C799	CCMB-J560J-0BZ	CAPACITOR CHIP/MULT	56PF	J 50V	Z B	
C738	CEET-C102M-HJ1	CAPACITOR E/ALUMINUM	1000uF	6.3V 10x12.5	SMS T	
C739	CEET-C102M-HJ1	CAPACITOR E/ALUMINUM	1000uF	6.3V 10x12.5	SMS T	
C802	CEET-E100M-AC0	CAPACITOR E/ALUMINUM	10uF	M 16V 3.5x5	T	
C804	CEET-E100M-AC0	CAPACITOR E/ALUMINUM	10uF	M 16V 3.5x5	T	
C805	CEET-E100M-AC0	CAPACITOR E/ALUMINUM	10uF	M 16V 3.5x5	T	
C807	CEET-E100M-AC0	CAPACITOR E/ALUMINUM	10uF	M 16V 3.5x5	T	
C743	CEET-E221M-FI0	CAPACITOR E/ALUMINUM	220uF	M 16V 8x11.5	T	
C745	CEET-E221M-FI0	CAPACITOR E/ALUMINUM	220uF	M 16V 8x11.5	T	
C780	CEET-E221M-FI0	CAPACITOR E/ALUMINUM	220uF	M 16V 8x11.5	T	
C729	CEET-E222M-KL0	CAPACITOR E/ALUMINUM	2200uF	M 16V 12.5x16	T	
C709	CEET-E331M-FI0	CAPACITOR E/ALUMINUM	330uF	M 16V 8x11.5	T	
C730	CEET-E331M-FI0	CAPACITOR E/ALUMINUM	330uF	M 16V 8x11.5	T	
C740	CEET-E331M-FI0	CAPACITOR E/ALUMINUM	330uF	M 16V 8x11.5	T	
C741	CEET-E331M-FI0	CAPACITOR E/ALUMINUM	330uF	M 16V 8x11.5	T	
C774	CEET-E331M-FI0	CAPACITOR E/ALUMINUM	330uF	M 16V 8x11.5	T	
C671	CEET-F330M-CI0	CAPACITOR E/ALUMINUM	33uF	M 25V 5x11	T	
C672	CEET-F330M-CI0	CAPACITOR E/ALUMINUM	33uF	M 25V 5x11	T	
C673	CEET-F330M-CI0	CAPACITOR E/ALUMINUM	33uF	M 25V 5x11	T	
C676	CEET-F330M-CI0	CAPACITOR E/ALUMINUM	33uF	M 25V 5x11	T	
C677	CEET-F330M-CI0	CAPACITOR E/ALUMINUM	33uF	M 25V 5x11	T	
C678	CEET-F330M-CI0	CAPACITOR E/ALUMINUM	33uF	M 25V 5x11	T	
C679	CEET-F330M-CI0	CAPACITOR E/ALUMINUM	33uF	M 25V 5x11	T	
C680	CEET-F330M-CI0	CAPACITOR E/ALUMINUM	33uF	M 25V 5x11	T	
C689	CEET-F330M-CI0	CAPACITOR E/ALUMINUM	33uF	M 25V 5x11	T	
C690	CEET-F330M-CI0	CAPACITOR E/ALUMINUM	33uF	M 25V 5x11	T	
C698	CEET-F330M-CI0	CAPACITOR E/ALUMINUM	33uF	M 25V 5x11	T	
C699	CEET-F330M-CI0	CAPACITOR E/ALUMINUM	33uF	M 25V 5x11	T	
C700	CEET-F330M-CI0	CAPACITOR E/ALUMINUM	33uF	M 25V 5x11	T	
C715	CEET-F330M-CI0	CAPACITOR E/ALUMINUM	33uF	M 25V 5x11	T	
C716	CEET-F330M-CI0	CAPACITOR E/ALUMINUM	33uF	M 25V 5x11	T	
C721	CEET-F330M-CI0	CAPACITOR E/ALUMINUM	33uF	M 25V 5x11	T	
C725	CEET-F330M-CI0	CAPACITOR E/ALUMINUM	33uF	M 25V 5x11	T	
C765	CEET-F330M-CI0	CAPACITOR E/ALUMINUM	33uF	M 25V 5x11	T	
C797	CEET-F330M-CI0	CAPACITOR E/ALUMINUM	33uF	M 25V 5x11	T	
C800	CEET-F330M-CI0	CAPACITOR E/ALUMINUM	33uF	M 25V 5x11	T	
C684	CEET-F470M-CI0	CAPACITOR E/ALUMINUM	47uF	M 25V 5x11	T	
C685	CEET-F470M-CI0	CAPACITOR E/ALUMINUM	47uF	M 25V 5x11	T	
C694	CEET-F470M-CI0	CAPACITOR E/ALUMINUM	47uF	M 25V 5x11	T	
C695	CEET-F470M-CI0	CAPACITOR E/ALUMINUM	47uF	M 25V 5x11	T	
C707	CEET-F470M-CI0	CAPACITOR E/ALUMINUM	47uF	M 25V 5x11	T	
C708	CEET-F470M-CI0	CAPACITOR E/ALUMINUM	47uF	M 25V 5x11	T	
C713	CEET-F470M-CI0	CAPACITOR E/ALUMINUM	47uF	M 25V 5x11	T	
C714	CEET-F470M-CI0	CAPACITOR E/ALUMINUM	47uF	M 25V 5x11	T	
C717	CEET-F470M-CI0	CAPACITOR E/ALUMINUM	47uF	M 25V 5x11	T	



## ELECTRICAL PART LIST

C718	CEET-F470M-CI0	CAPACITOR E/ALUMINUM	47uF	M	25V 5x11	T
C723	CEET-F470M-CI0	CAPACITOR E/ALUMINUM	47uF	M	25V 5x11	T
C724	CEET-F470M-CI0	CAPACITOR E/ALUMINUM	47uF	M	25V 5x11	T
C727	CEET-F470M-CI0	CAPACITOR E/ALUMINUM	47uF	M	25V 5x11	T
C731	CEET-F470M-CI0	CAPACITOR E/ALUMINUM	47uF	M	25V 5x11	T
C732	CEET-F470M-CI0	CAPACITOR E/ALUMINUM	47uF	M	25V 5x11	T
C734	CEET-F470M-CI0	CAPACITOR E/ALUMINUM	47uF	M	25V 5x11	T
C735	CEET-F470M-CI0	CAPACITOR E/ALUMINUM	47uF	M	25V 5x11	T
C755	CEET-F470M-CI0	CAPACITOR E/ALUMINUM	47uF	M	25V 5x11	T
C766	CEET-F470M-CI0	CAPACITOR E/ALUMINUM	47uF	M	25V 5x11	T
C872	CEET-F470M-CI0	CAPACITOR E/ALUMINUM	47uF	M	25V 5x11	T
C792	CEET-G100M-CI0	CAPACITOR E/ALUMINUM	10uF	M	35V 5x11	T
C789	CEET-JR33M-CI0	CAPACITOR E/ALUMINUM	0.33uF	M	50V 5x11	T
C722	CEET-J1R0M-CI0	CAPACITOR E/ALUMINUM	1.0uF	M	50V 5x11	T
C733	CEET-J1R0M-CI0	CAPACITOR E/ALUMINUM	1.0uF	M	50V 5x11	T
C788	CEET-J1R0M-CI0	CAPACITOR E/ALUMINUM	1.0uF	M	50V 5x11	T
C801	CEET-J1R0M-CI0	CAPACITOR E/ALUMINUM	1.0uF	M	50V 5x11	T
C808	CEET-J1R0M-CI0	CAPACITOR E/ALUMINUM	1.0uF	M	50V 5x11	T
C726	CEET-J100M-CI0	CAPACITOR E/ALUMINUM	10uF	M	50V 5x11	T
C639	CEET-J4R7M-CI0	CAPACITOR E/ALUMINUM	4.7uF	M	50V 5x11	T
C641	CEET-J4R7M-CI0	CAPACITOR E/ALUMINUM	4.7uF	M	50V 5x11	T
C643	CEET-J4R7M-CI0	CAPACITOR E/ALUMINUM	4.7uF	M	50V 5x11	T
C664	CEET-J4R7M-CI0	CAPACITOR E/ALUMINUM	4.7uF	M	50V 5x11	T
C666	CEET-J4R7M-CI0	CAPACITOR E/ALUMINUM	4.7uF	M	50V 5x11	T
C674	CEET-J4R7M-CI0	CAPACITOR E/ALUMINUM	4.7uF	M	50V 5x11	T
C675	CEET-J4R7M-CI0	CAPACITOR E/ALUMINUM	4.7uF	M	50V 5x11	T
C681	CEET-J4R7M-CI0	CAPACITOR E/ALUMINUM	4.7uF	M	50V 5x11	T
C686	CEET-J4R7M-CI0	CAPACITOR E/ALUMINUM	4.7uF	M	50V 5x11	T
C688	CEET-J4R7M-CI0	CAPACITOR E/ALUMINUM	4.7uF	M	50V 5x11	T
C711	CEET-J4R7M-CI0	CAPACITOR E/ALUMINUM	4.7uF	M	50V 5x11	T
C712	CEET-J4R7M-CI0	CAPACITOR E/ALUMINUM	4.7uF	M	50V 5x11	T
C719	CEET-J4R7M-CI0	CAPACITOR E/ALUMINUM	4.7uF	M	50V 5x11	T
C720	CEET-J4R7M-CI0	CAPACITOR E/ALUMINUM	4.7uF	M	50V 5x11	T
C790	CEET-J4R7M-CI0	CAPACITOR E/ALUMINUM	4.7uF	M	50V 5x11	T
C791	CEET-J4R7M-CI0	CAPACITOR E/ALUMINUM	4.7uF	M	50V 5x11	T
C793	CEET-J4R7M-CI0	CAPACITOR E/ALUMINUM	4.7uF	M	50V 5x11	T
C794	CEET-J4R7M-CI0	CAPACITOR E/ALUMINUM	4.7uF	M	50V 5x11	T
C795	CEET-J4R7M-CI0	CAPACITOR E/ALUMINUM	4.7uF	M	50V 5x11	T
C798	CEET-J4R7M-CI0	CAPACITOR E/ALUMINUM	4.7uF	M	50V 5x11	T
BC601	CEGT-B104J-OJ0	CAPACITOR E/DO LAYER	0.1F	J	5.5V SCD45R5104A	T
C628	CFMT-N104J-JK0	CAPACITOR F/POLYESTR	0.10uF	J	100V 12.1x14	T
C630	CFMT-N104J-JK0	CAPACITOR F/POLYESTR	0.10uF	J	100V 12.1x14	T
C627	CFMT-N152J-CJ0	CAPACITOR F/POLYESTR	0.0015uF	J	100V 5.4x12	T
C629	CFMT-N152J-CJ0	CAPACITOR F/POLYESTR	0.0015uF	J	100V 5.4x12	T
D601	DDTR-00040-T10	DIODE-RECTIFIER	1N4004S	(400V 1A 0.6mm)	T	
D602	DDTS-00070-S00	DIODE-SI	1SS133	(40V 0.11A) DO-40	T	
D603	DDTS-00070-S00	DIODE-SI	1SS133	(40V 0.11A) DO-40	T	
D604	DDTS-00070-S00	DIODE-SI	1SS133	(40V 0.11A) DO-40	T	
D605	DDTS-00070-S00	DIODE-SI	1SS133	(40V 0.11A) DO-40	T	
D606	DDTS-00070-S00	DIODE-SI	1SS133	(40V 0.11A) DO-40	T	
D609	DDTS-00070-S00	DIODE-SI	1SS133	(40V 0.11A) DO-40	T	
D610	DDTS-00070-S00	DIODE-SI	1SS133	(40V 0.11A) DO-40	T	
D611	DDTS-00070-S00	DIODE-SI	1SS133	(40V 0.11A) DO-40	T	
D612	DDTS-00070-S00	DIODE-SI	1SS133	(40V 0.11A) DO-40	T	
D613	DDTS-00070-S00	DIODE-SI	1SS133	(40V 0.11A) DO-40	T	
D614	DDTS-00070-S00	DIODE-SI	1SS133	(40V 0.11A) DO-40	T	
IC622	ESRY-00460-120	RELAY	V23079-A1003-B301	12V		
IC614	ICCM-01300-SD0	IC VOLUME CONTROL IC	KIC9459F	SOP24		
IC616	ICCM-01300-SD0	IC VOLUME CONTROL IC	KIC9459F	SOP24		
IC618	ICCM-01490-TK0	IC EEPROM	AT24C32N-10SC-2.7			
IC612	ICCM-21100-S30	IC ANALOG SWITCH	TC9273	SOP 28		
IC613	ICCM-21100-S30	IC ANALOG SWITCH	TC9273	SOP 28		
IC615	ICLN-03590-S10	IC ANALOG FUNCTION	LC78213	DIP30		
IC608	ICMP-03020-UT0	IC MICOM	UPD78F4216AGF			
IC602	ICOP-00134-SG0	IC DUAL OP AMP	NJM4558M	SOP8		
IC603	ICOP-00134-SG0	IC DUAL OP AMP	NJM4558M	SOP8		
IC604	ICOP-00134-SG0	IC DUAL OP AMP	NJM4558M	SOP8		
IC605	ICOP-00134-SG0	IC DUAL OP AMP	NJM4558M	SOP8		
IC606	ICOP-00134-SG0	IC DUAL OP AMP	NJM4558M	SOP8		
IC607	ICOP-00134-SG0	IC DUAL OP AMP	NJM4558M	SOP8		
IC619	ICOP-00134-SG0	IC DUAL OP AMP	NJM4558M	SOP8		
IC620	ICOP-00134-SG0	IC DUAL OP AMP	NJM4558M	SOP8		
IC621	ICOP-00134-SG0	IC DUAL OP AMP	NJM4558M	SOP8		
IC611	ICOP-03120-SG0	IC DUAL OP AMP	NJM4580D			
IC610	ICPC-00010-TB0	IC PHOTOCOUPLER	LTV817B	DIP4		
IC617	ICPC-00010-TB0	IC PHOTOCOUPLER	LTV817B	DIP4		
L703	KI0T-4100K-003	COIL-INDUCTOR	10uH	K LAL02	T	

## ELECTRICAL PART LIST

CN601 KNCW-00240-AT9 CONNECTOR-WAFER	53014-10 2.0mm WHT
CN609 KNCW-00240-4T9 CONNECTOR-WAFER	53014-04 2.0mm WHT
CN617 KNCW-00240-6T9 CONNECTOR-WAFER	53014-06 2.0mm WHT
CN615 KNCW-00240-7T9 CONNECTOR-WAFER	53014-07 2.0mm WHT
CN604 KNCW-00760-AT0 CONNECTOR-WAFER	8370-101 1.25mm TOP 10P
CN603 KNCW-00760-DT0 CONNECTOR-WAFER	8370-131 1.25mm TOP 13P
CN602 KNCW-00760-IT0 CONNECTOR-WAFER	8370-181 1.25mm TOP 18P
CN605 KNCW-00760-IT0 CONNECTOR-WAFER	8370-181 1.25mm TOP 18P
CN608 KNCW-00760-ST0 CONNECTOR-WAFER	8370-281 1.25mm TOP 28P
CN610 KNCW-00760-UT0 CONNECTOR-WAFER	8370-301 1.25mm TOP 30P
L701 KORB-00100-000 CHIP FERRITE BEADS	HB-1T2012-601
L702 KORB-00100-000 CHIP FERRITE BEADS	HB-1T2012-601
L704 KORB-00110-000 EMI BEAD FILTER	ATS3580I(MATERIAL:M3L)
X601 KTRE-00210-120 RESONATOR	CST12.0MTW-TF01
PCB1 PCSR-06070-11B PCB-SINGLE	A1R-607
R769 RCPB-B101J-21C RESISTOR-CHIP C/FILM	100ohm 1/10W 5% B
R864 RCPB-B101J-21C RESISTOR-CHIP C/FILM	100ohm 1/10W 5% B
R865 RCPB-B101J-21C RESISTOR-CHIP C/FILM	100ohm 1/10W 5% B
R868 RCPB-B101J-21C RESISTOR-CHIP C/FILM	100ohm 1/10W 5% B
R869 RCPB-B101J-21C RESISTOR-CHIP C/FILM	100ohm 1/10W 5% B
R872 RCPB-B101J-21C RESISTOR-CHIP C/FILM	100ohm 1/10W 5% B
R879 RCPB-B101J-21C RESISTOR-CHIP C/FILM	100ohm 1/10W 5% B
R883 RCPB-B101J-21C RESISTOR-CHIP C/FILM	100ohm 1/10W 5% B
R891 RCPB-B101J-21C RESISTOR-CHIP C/FILM	100ohm 1/10W 5% B
R625 RCPB-B102J-21C RESISTOR-CHIP C/FILM	1Kohm 1/10W 5% B
R626 RCPB-B102J-21C RESISTOR-CHIP C/FILM	1Kohm 1/10W 5% B
R629 RCPB-B102J-21C RESISTOR-CHIP C/FILM	1Kohm 1/10W 5% B
R630 RCPB-B102J-21C RESISTOR-CHIP C/FILM	1Kohm 1/10W 5% B
R631 RCPB-B102J-21C RESISTOR-CHIP C/FILM	1Kohm 1/10W 5% B
R632 RCPB-B102J-21C RESISTOR-CHIP C/FILM	1Kohm 1/10W 5% B
R636 RCPB-B102J-21C RESISTOR-CHIP C/FILM	1Kohm 1/10W 5% B
R637 RCPB-B102J-21C RESISTOR-CHIP C/FILM	1Kohm 1/10W 5% B
R638 RCPB-B102J-21C RESISTOR-CHIP C/FILM	1Kohm 1/10W 5% B
R639 RCPB-B102J-21C RESISTOR-CHIP C/FILM	1Kohm 1/10W 5% B
R640 RCPB-B102J-21C RESISTOR-CHIP C/FILM	1Kohm 1/10W 5% B
R641 RCPB-B102J-21C RESISTOR-CHIP C/FILM	1Kohm 1/10W 5% B
R642 RCPB-B102J-21C RESISTOR-CHIP C/FILM	1Kohm 1/10W 5% B
R643 RCPB-B102J-21C RESISTOR-CHIP C/FILM	1Kohm 1/10W 5% B
R656 RCPB-B102J-21C RESISTOR-CHIP C/FILM	1Kohm 1/10W 5% B
R657 RCPB-B102J-21C RESISTOR-CHIP C/FILM	1Kohm 1/10W 5% B
R658 RCPB-B102J-21C RESISTOR-CHIP C/FILM	1Kohm 1/10W 5% B
R659 RCPB-B102J-21C RESISTOR-CHIP C/FILM	1Kohm 1/10W 5% B
R660 RCPB-B102J-21C RESISTOR-CHIP C/FILM	1Kohm 1/10W 5% B
R661 RCPB-B102J-21C RESISTOR-CHIP C/FILM	1Kohm 1/10W 5% B
R662 RCPB-B102J-21C RESISTOR-CHIP C/FILM	1Kohm 1/10W 5% B
R663 RCPB-B102J-21C RESISTOR-CHIP C/FILM	1Kohm 1/10W 5% B
R664 RCPB-B102J-21C RESISTOR-CHIP C/FILM	1Kohm 1/10W 5% B
R665 RCPB-B102J-21C RESISTOR-CHIP C/FILM	1Kohm 1/10W 5% B
R667 RCPB-B102J-21C RESISTOR-CHIP C/FILM	1Kohm 1/10W 5% B
R668 RCPB-B102J-21C RESISTOR-CHIP C/FILM	1Kohm 1/10W 5% B
R669 RCPB-B102J-21C RESISTOR-CHIP C/FILM	1Kohm 1/10W 5% B
R670 RCPB-B102J-21C RESISTOR-CHIP C/FILM	1Kohm 1/10W 5% B
R671 RCPB-B102J-21C RESISTOR-CHIP C/FILM	1Kohm 1/10W 5% B
R672 RCPB-B102J-21C RESISTOR-CHIP C/FILM	1Kohm 1/10W 5% B
R673 RCPB-B102J-21C RESISTOR-CHIP C/FILM	1Kohm 1/10W 5% B
R674 RCPB-B102J-21C RESISTOR-CHIP C/FILM	1Kohm 1/10W 5% B
R692 RCPB-B102J-21C RESISTOR-CHIP C/FILM	1Kohm 1/10W 5% B
R693 RCPB-B102J-21C RESISTOR-CHIP C/FILM	1Kohm 1/10W 5% B
R694 RCPB-B102J-21C RESISTOR-CHIP C/FILM	1Kohm 1/10W 5% B
R702 RCPB-B102J-21C RESISTOR-CHIP C/FILM	1Kohm 1/10W 5% B
R703 RCPB-B102J-21C RESISTOR-CHIP C/FILM	1Kohm 1/10W 5% B
R704 RCPB-B102J-21C RESISTOR-CHIP C/FILM	1Kohm 1/10W 5% B
R760 RCPB-B102J-21C RESISTOR-CHIP C/FILM	1Kohm 1/10W 5% B
R761 RCPB-B102J-21C RESISTOR-CHIP C/FILM	1Kohm 1/10W 5% B
R764 RCPB-B102J-21C RESISTOR-CHIP C/FILM	1Kohm 1/10W 5% B
R765 RCPB-B102J-21C RESISTOR-CHIP C/FILM	1Kohm 1/10W 5% B
R767 RCPB-B102J-21C RESISTOR-CHIP C/FILM	1Kohm 1/10W 5% B
R772 RCPB-B102J-21C RESISTOR-CHIP C/FILM	1Kohm 1/10W 5% B
R773 RCPB-B102J-21C RESISTOR-CHIP C/FILM	1Kohm 1/10W 5% B
R780 RCPB-B102J-21C RESISTOR-CHIP C/FILM	1Kohm 1/10W 5% B
R845 RCPB-B102J-21C RESISTOR-CHIP C/FILM	1Kohm 1/10W 5% B
R849 RCPB-B102J-21C RESISTOR-CHIP C/FILM	1Kohm 1/10W 5% B
R850 RCPB-B102J-21C RESISTOR-CHIP C/FILM	1Kohm 1/10W 5% B
R856 RCPB-B102J-21C RESISTOR-CHIP C/FILM	1Kohm 1/10W 5% B
R857 RCPB-B102J-21C RESISTOR-CHIP C/FILM	1Kohm 1/10W 5% B
R627 RCPB-B103J-21C RESISTOR-CHIP C/FILM	10Kohm 1/10W 5% B





## ELECTRICAL PART LIST

R855	RCPB-B331J-21C	RESISTOR-CHIP C/FILM	330ohm	1/10W	5%	B
R762	RCPB-B332J-21C	RESISTOR-CHIP C/FILM	3.3Kohm	1/10W	5%	B
R763	RCPB-B332J-21C	RESISTOR-CHIP C/FILM	3.3Kohm	1/10W	5%	B
R826	RCPB-B332J-21C	RESISTOR-CHIP C/FILM	3.3Kohm	1/10W	5%	B
R649	RCPB-B392J-21C	RESISTOR-CHIP C/FILM	3.9Kohm	1/10W	5%	B
R648	RCPB-B470J-21C	RESISTOR-CHIP C/FILM	47ohm	1/10W	5%	B
R651	RCPB-B470J-21C	RESISTOR-CHIP C/FILM	47ohm	1/10W	5%	B
R601	RCPB-B471J-21C	RESISTOR-CHIP C/FILM	470ohm	1/10W	5%	B
R602	RCPB-B471J-21C	RESISTOR-CHIP C/FILM	470ohm	1/10W	5%	B
R605	RCPB-B471J-21C	RESISTOR-CHIP C/FILM	470ohm	1/10W	5%	B
R606	RCPB-B471J-21C	RESISTOR-CHIP C/FILM	470ohm	1/10W	5%	B
R607	RCPB-B471J-21C	RESISTOR-CHIP C/FILM	470ohm	1/10W	5%	B
R608	RCPB-B471J-21C	RESISTOR-CHIP C/FILM	470ohm	1/10W	5%	B
R609	RCPB-B471J-21C	RESISTOR-CHIP C/FILM	470ohm	1/10W	5%	B
R610	RCPB-B471J-21C	RESISTOR-CHIP C/FILM	470ohm	1/10W	5%	B
R611	RCPB-B471J-21C	RESISTOR-CHIP C/FILM	470ohm	1/10W	5%	B
R612	RCPB-B471J-21C	RESISTOR-CHIP C/FILM	470ohm	1/10W	5%	B
R613	RCPB-B471J-21C	RESISTOR-CHIP C/FILM	470ohm	1/10W	5%	B
R614	RCPB-B471J-21C	RESISTOR-CHIP C/FILM	470ohm	1/10W	5%	B
R621	RCPB-B471J-21C	RESISTOR-CHIP C/FILM	470ohm	1/10W	5%	B
R622	RCPB-B471J-21C	RESISTOR-CHIP C/FILM	470ohm	1/10W	5%	B
R647	RCPB-B471J-21C	RESISTOR-CHIP C/FILM	470ohm	1/10W	5%	B
R713	RCPB-B471J-21C	RESISTOR-CHIP C/FILM	470ohm	1/10W	5%	B
R714	RCPB-B471J-21C	RESISTOR-CHIP C/FILM	470ohm	1/10W	5%	B
R722	RCPB-B471J-21C	RESISTOR-CHIP C/FILM	470ohm	1/10W	5%	B
R723	RCPB-B471J-21C	RESISTOR-CHIP C/FILM	470ohm	1/10W	5%	B
R728	RCPB-B471J-21C	RESISTOR-CHIP C/FILM	470ohm	1/10W	5%	B
R729	RCPB-B471J-21C	RESISTOR-CHIP C/FILM	470ohm	1/10W	5%	B
R735	RCPB-B471J-21C	RESISTOR-CHIP C/FILM	470ohm	1/10W	5%	B
R737	RCPB-B471J-21C	RESISTOR-CHIP C/FILM	470ohm	1/10W	5%	B
R742	RCPB-B471J-21C	RESISTOR-CHIP C/FILM	470ohm	1/10W	5%	B
R743	RCPB-B471J-21C	RESISTOR-CHIP C/FILM	470ohm	1/10W	5%	B
R747	RCPB-B471J-21C	RESISTOR-CHIP C/FILM	470ohm	1/10W	5%	B
R787	RCPB-B471J-21C	RESISTOR-CHIP C/FILM	470ohm	1/10W	5%	B
R792	RCPB-B471J-21C	RESISTOR-CHIP C/FILM	470ohm	1/10W	5%	B
R813	RCPB-B471J-21C	RESISTOR-CHIP C/FILM	470ohm	1/10W	5%	B
R854	RCPB-B471J-21C	RESISTOR-CHIP C/FILM	470ohm	1/10W	5%	B
R871	RCPB-B471J-21C	RESISTOR-CHIP C/FILM	470ohm	1/10W	5%	B
R874	RCPB-B471J-21C	RESISTOR-CHIP C/FILM	470ohm	1/10W	5%	B
R881	RCPB-B471J-21C	RESISTOR-CHIP C/FILM	470ohm	1/10W	5%	B
R885	RCPB-B471J-21C	RESISTOR-CHIP C/FILM	470ohm	1/10W	5%	B
R819	RCPB-B472J-21C	RESISTOR-CHIP C/FILM	4.7Kohm	1/10W	5%	B
R846	RCPB-B472J-21C	RESISTOR-CHIP C/FILM	4.7Kohm	1/10W	5%	B
R650	RCPB-B473J-21C	RESISTOR-CHIP C/FILM	47Kohm	1/10W	5%	B
R653	RCPB-B473J-21C	RESISTOR-CHIP C/FILM	47Kohm	1/10W	5%	B
R831	RCPB-B473J-21C	RESISTOR-CHIP C/FILM	47Kohm	1/10W	5%	B
R832	RCPB-B473J-21C	RESISTOR-CHIP C/FILM	47Kohm	1/10W	5%	B
R833	RCPB-B473J-21C	RESISTOR-CHIP C/FILM	47Kohm	1/10W	5%	B
R834	RCPB-B473J-21C	RESISTOR-CHIP C/FILM	47Kohm	1/10W	5%	B
R835	RCPB-B473J-21C	RESISTOR-CHIP C/FILM	47Kohm	1/10W	5%	B
R836	RCPB-B473J-21C	RESISTOR-CHIP C/FILM	47Kohm	1/10W	5%	B
R837	RCPB-B473J-21C	RESISTOR-CHIP C/FILM	47Kohm	1/10W	5%	B
R838	RCPB-B473J-21C	RESISTOR-CHIP C/FILM	47Kohm	1/10W	5%	B
R839	RCPB-B473J-21C	RESISTOR-CHIP C/FILM	47Kohm	1/10W	5%	B
R840	RCPB-B473J-21C	RESISTOR-CHIP C/FILM	47Kohm	1/10W	5%	B
R841	RCPB-B473J-21C	RESISTOR-CHIP C/FILM	47Kohm	1/10W	5%	B
R842	RCPB-B473J-21C	RESISTOR-CHIP C/FILM	47Kohm	1/10W	5%	B
R816	RCPB-B561J-21C	RESISTOR-CHIP C/FILM	560ohm	1/10W	5%	B
R766	RCPB-B6R8J-21C	RESISTOR-CHIP C/FILM	6.8ohm	1/10W	5%	B
R768	RCPB-B6R8J-21C	RESISTOR-CHIP C/FILM	6.8ohm	1/10W	5%	B
R655	RCPB-B821J-21C	RESISTOR-CHIP C/FILM	820ohm	1/10W	5%	B
R666	RCPB-B821J-21C	RESISTOR-CHIP C/FILM	820ohm	1/10W	5%	B
R890	RCPB-B823J-21C	RESISTOR-CHIP C/FILM	82Kohm	1/10W	5%	B
JK609	SKPH-00400-360	SOCKET-PHONE	LGY6502-0600			
JK606	SKPH-00520-360	MINIATURE JACK	HSJ1002-01-1020			
JK614	SKRC-00840-02P	SOCKET-RCA	JK020130CG			
JK611	SKRC-01281-06P	PIN JACK BOARD	JS060132JG			
JK612	SKRC-01281-06P	PIN JACK BOARD	JS060132JG			
JK613	SKRC-01281-06P	PIN JACK BOARD	JS060132JG			
Q638	TRTA-0008G-SD0	TRANSISTOR P-H FREQ	KTA1266-GR			TO92
Q626	TRTA-0012Y-SD0	TRANSISTOR P-H FREQ	KTA1273-Y			TO92L
Q603	TRTA-00940-SD0	TRANSISTOR P-H FREQ	KRA107M			W/RESIST TO92M
Q606	TRTA-00940-SD0	TRANSISTOR P-H FREQ	KRA107M			W/RESIST TO92M
Q607	TRTA-00940-SD0	TRANSISTOR P-H FREQ	KRA107M			W/RESIST TO92M

ELECTRICAL PART LIST

Q608	TRTA-00940-SD0	TRANSISTOR P-H FREQ	KRA107M	W/RESIST TO92M
Q615	TRTA-00940-SD0	TRANSISTOR P-H FREQ	KRA107M	W/RESIST TO92M
Q621	TRTA-00940-SD0	TRANSISTOR P-H FREQ	KRA107M	W/RESIST TO92M
Q623	TRTA-00940-SD0	TRANSISTOR P-H FREQ	KRA107M	W/RESIST TO92M
Q627	TRTA-00940-SD0	TRANSISTOR P-H FREQ	KRA107M	W/RESIST TO92M
Q630	TRTA-00940-SD0	TRANSISTOR P-H FREQ	KRA107M	W/RESIST TO92M
Q635	TRTA-00940-SD0	TRANSISTOR P-H FREQ	KRA107M	W/RESIST TO92M
Q636	TRTA-00940-SD0	TRANSISTOR P-H FREQ	KRA107M	W/RESIST TO92M
Q642	TRTA-00940-SD0	TRANSISTOR P-H FREQ	KRA107M	W/RESIST TO92M
Q644	TRTA-00940-SD0	TRANSISTOR P-H FREQ	KRA107M	W/RESIST TO92M
Q646	TRTA-00940-SD0	TRANSISTOR P-H FREQ	KRA107M	W/RESIST TO92M
Q648	TRTA-00940-SD0	TRANSISTOR P-H FREQ	KRA107M	W/RESIST TO92M
Q609	TRTC-0016G-SD0	TRANSISTOR N-H FREQ	KTC3198-GR	TO92
Q604	TRTC-01700-SD0	TRANSISTOR N-H FREQ	KRC107M	W/RESIST TO92M
Q605	TRTC-01700-SD0	TRANSISTOR N-H FREQ	KRC107M	W/RESIST TO92M
Q612	TRTC-01700-SD0	TRANSISTOR N-H FREQ	KRC107M	W/RESIST TO92M
Q624	TRTC-01700-SD0	TRANSISTOR N-H FREQ	KRC107M	W/RESIST TO92M
Q631	TRTC-01700-SD0	TRANSISTOR N-H FREQ	KRC107M	W/RESIST TO92M
Q632	TRTC-01700-SD0	TRANSISTOR N-H FREQ	KRC107M	W/RESIST TO92M
Q633	TRTC-01700-SD0	TRANSISTOR N-H FREQ	KRC107M	W/RESIST TO92M
Q634	TRTC-01700-SD0	TRANSISTOR N-H FREQ	KRC107M	W/RESIST TO92M
Q637	TRTC-01700-SD0	TRANSISTOR N-H FREQ	KRC107M	W/RESIST TO92M
Q641	TRTC-01700-SD0	TRANSISTOR N-H FREQ	KRC107M	W/RESIST TO92M
Q643	TRTC-01700-SD0	TRANSISTOR N-H FREQ	KRC107M	W/RESIST TO92M
Q645	TRTC-01700-SD0	TRANSISTOR N-H FREQ	KRC107M	W/RESIST TO92M
Q647	TRTC-01700-SD0	TRANSISTOR N-H FREQ	KRC107M	W/RESIST TO92M
Q625	TRTC-02050-SD0	TRANSISTOR N-H FREQ	KRC120M	W/RESIST TO92M
Q601	TRTD-00200-SD0	TRANSISTOR N-L FREQ	KTD-1302	TO92
Q602	TRTD-00200-SD0	TRANSISTOR N-L FREQ	KTD-1302	TO92
Q610	TRTD-00200-SD0	TRANSISTOR N-L FREQ	KTD-1302	TO92
Q611	TRTD-00200-SD0	TRANSISTOR N-L FREQ	KTD-1302	TO92
Q613	TRTD-00200-SD0	TRANSISTOR N-L FREQ	KTD-1302	TO92
Q614	TRTD-00200-SD0	TRANSISTOR N-L FREQ	KTD-1302	TO92
Q616	TRTD-00200-SD0	TRANSISTOR N-L FREQ	KTD-1302	TO92
Q617	TRTD-00200-SD0	TRANSISTOR N-L FREQ	KTD-1302	TO92
Q618	TRTD-00200-SD0	TRANSISTOR N-L FREQ	KTD-1302	TO92
Q619	TRTD-00200-SD0	TRANSISTOR N-L FREQ	KTD-1302	TO92
Q620	TRTD-00200-SD0	TRANSISTOR N-L FREQ	KTD-1302	TO92
Q622	TRTD-00200-SD0	TRANSISTOR N-L FREQ	KTD-1302	TO92
Q628	TRTD-00200-SD0	TRANSISTOR N-L FREQ	KTD-1302	TO92
Q629	TRTD-00200-SD0	TRANSISTOR N-L FREQ	KTD-1302	TO92
Q639	TRTD-00200-SD0	TRANSISTOR N-L FREQ	KTD-1302	TO92
Q640	TRTD-00200-SD0	TRANSISTOR N-L FREQ	KTD-1302	TO92
Q649	TRTD-00200-SD0	TRANSISTOR N-L FREQ	KTD-1302	TO92
Q650	TRTD-00200-SD0	TRANSISTOR N-L FREQ	KTD-1302	TO92
Q651	TRTD-00200-SD0	TRANSISTOR N-L FREQ	KTD-1302	TO92
Q652	TRTD-00200-SD0	TRANSISTOR N-L FREQ	KTD-1302	TO92
Q653	TRTD-00200-SD0	TRANSISTOR N-L FREQ	KTD-1302	TO92
CN616	UM08-D1073-000	WIRE-ASS'Y	1533/2547#28	GRY-250 13P
CN612	UM08-F1076-000	WIRE-ASS'Y	1533/2547#28	GRY-220 15P
CN618	UM08-F1077-000	WIRE-ASS'Y	1533/2547#28	GRY-280 15P
	UM08-61071-000	WIRE-ASS'Y	1007#26/1533#28	BRN-400 6P
CN619	U408-80845-Z50	WIER ASS'Y	4PH-4PH	1533#28 GY 450
CN617	U608-01745-T10	WIRE-ASS'Y	1007#26	BLK-45 6P
CN620	U708-6M534-Z00	WIER ASS'Y	7PH-7PH	1007#26 BL/BK 340
CN613	U810-7M516-200	WIRE-ASS'Y	1007#22	VIT-160 8P
CN607	U910-8M525-200	WIRE-ASS'Y	1007#22	GRY-250 9P

V I D E O

LOCNUM	SONITM	MATDES	MATSPC
C343	CCMB-J100D-0BZ	CAPACITOR CHIP/MULT	10PF D 50V Z B
C344	CCMB-J100D-0BZ	CAPACITOR CHIP/MULT	10PF D 50V Z B
C346	CCMB-J100D-0BZ	CAPACITOR CHIP/MULT	10PF D 50V Z B
C316	CCMB-J101J-0BZ	CAPACITOR CHIP/MULT	100PF J 50V Z B
C317	CCMB-J101J-0BZ	CAPACITOR CHIP/MULT	100PF J 50V Z B
C318	CCMB-J101J-0BZ	CAPACITOR CHIP/MULT	100PF J 50V Z B
C327	CCMB-J101J-0BZ	CAPACITOR CHIP/MULT	100PF J 50V Z B
C328	CCMB-J101J-0BZ	CAPACITOR CHIP/MULT	100PF J 50V Z B
C329	CCMB-J101J-0BZ	CAPACITOR CHIP/MULT	100PF J 50V Z B
C3304	CCMB-J101J-0BZ	CAPACITOR CHIP/MULT	100PF J 50V Z B
C3325	CCMB-J101J-0BZ	CAPACITOR CHIP/MULT	100PF J 50V Z B
C3326	CCMB-J101J-0BZ	CAPACITOR CHIP/MULT	100PF J 50V Z B
C3328	CCMB-J101J-0BZ	CAPACITOR CHIP/MULT	100PF J 50V Z B



## ELECTRICAL PART LIST

C3302	CCMB-J222J-0BZ	CAPACITOR CHIP/MULT	2200PF	J	50V	Z	B	
C3413	CCMB-J222J-0BZ	CAPACITOR CHIP/MULT	2200PF	J	50V	Z	B	
C388	CCMB-J330J-0BC	CAPACITOR CHIP/MULT	33PF	J	50V	C	B	
C393	CCMB-J472K-0BB	CAPACITOR CHIP/MULT	4700PF	K	50V	X7R	B	
C3412	CCMB-J560J-0BZ	CAPACITOR CHIP/MULT	56PF	J	50V	Z	B	
C339	CCMB-J561J-0BZ	CAPACITOR CHIP/MULT	560PF	J	50V	Z	B	
C3399	CCMB-J561J-0BZ	CAPACITOR CHIP/MULT	560PF	J	50V	Z	B	
C320	CCTT-J100D-0BC	CAPACITOR CERAMIC	10PF	D	50V	CH	T	
C3301	CEET-D101M-CI0	CAPACITOR E/ALUMINUM	100uF	M	10V	5x11		T
C361	CEET-D101M-CI0	CAPACITOR E/ALUMINUM	100uF	M	10V	5x11		T
C374	CEET-D101M-CI0	CAPACITOR E/ALUMINUM	100uF	M	10V	5x11		T
C382	CEET-D101M-CI0	CAPACITOR E/ALUMINUM	100uF	M	10V	5x11		T
C392	CEET-D101M-CI0	CAPACITOR E/ALUMINUM	100uF	M	10V	5x11		T
C396	CEET-D101M-CI0	CAPACITOR E/ALUMINUM	100uF	M	10V	5x11		T
C303	CEET-D221M-DI0	CAPACITOR E/ALUMINUM	220uF	M	10V	6.3x11		T
C305	CEET-D221M-DI0	CAPACITOR E/ALUMINUM	220uF	M	10V	6.3x11		T
C309	CEET-D221M-DI0	CAPACITOR E/ALUMINUM	220uF	M	10V	6.3x11		T
C310	CEET-D221M-DI0	CAPACITOR E/ALUMINUM	220uF	M	10V	6.3x11		T
C314	CEET-D221M-DI0	CAPACITOR E/ALUMINUM	220uF	M	10V	6.3x11		T
C315	CEET-D221M-DI0	CAPACITOR E/ALUMINUM	220uF	M	10V	6.3x11		T
C325	CEET-D221M-DI0	CAPACITOR E/ALUMINUM	220uF	M	10V	6.3x11		T
C326	CEET-D221M-DI0	CAPACITOR E/ALUMINUM	220uF	M	10V	6.3x11		T
C3305	CEET-D221M-DI0	CAPACITOR E/ALUMINUM	220uF	M	10V	6.3x11		T
C367	CEET-D221M-DI0	CAPACITOR E/ALUMINUM	220uF	M	10V	6.3x11		T
C368	CEET-D221M-DI0	CAPACITOR E/ALUMINUM	220uF	M	10V	6.3x11		T
C369	CEET-D221M-DI0	CAPACITOR E/ALUMINUM	220uF	M	10V	6.3x11		T
C340	CEET-D471M-FI1	CAPACITOR E/ALUMINUM	470uF	M	10V	8x11.5		U T
C341	CEET-D471M-FI1	CAPACITOR E/ALUMINUM	470uF	M	10V	8x11.5		U T
C342	CEET-D471M-FI1	CAPACITOR E/ALUMINUM	470uF	M	10V	8x11.5		U T
C358	CEET-D471M-FI1	CAPACITOR E/ALUMINUM	470uF	M	10V	8x11.5		U T
C302	CEET-E100M-AC0	CAPACITOR E/ALUMINUM	10uF	M	16V	3.5x5		T
C304	CEET-E100M-AC0	CAPACITOR E/ALUMINUM	10uF	M	16V	3.5x5		T
C307	CEET-E100M-AC0	CAPACITOR E/ALUMINUM	10uF	M	16V	3.5x5		T
C308	CEET-E100M-AC0	CAPACITOR E/ALUMINUM	10uF	M	16V	3.5x5		T
C312	CEET-E100M-AC0	CAPACITOR E/ALUMINUM	10uF	M	16V	3.5x5		T
C313	CEET-E100M-AC0	CAPACITOR E/ALUMINUM	10uF	M	16V	3.5x5		T
C323	CEET-E100M-AC0	CAPACITOR E/ALUMINUM	10uF	M	16V	3.5x5		T
C324	CEET-E100M-AC0	CAPACITOR E/ALUMINUM	10uF	M	16V	3.5x5		T
C3400	CEET-E100M-AC0	CAPACITOR E/ALUMINUM	10uF	M	16V	3.5x5		T
C355	CEET-E100M-AC0	CAPACITOR E/ALUMINUM	10uF	M	16V	3.5x5		T
C360	CEET-E100M-AC0	CAPACITOR E/ALUMINUM	10uF	M	16V	3.5x5		T
C363	CEET-E100M-AC0	CAPACITOR E/ALUMINUM	10uF	M	16V	3.5x5		T
C3418	CEET-F330M-CI0	CAPACITOR E/ALUMINUM	33uF	M	25V	5x11		T
C3419	CEET-F330M-CI0	CAPACITOR E/ALUMINUM	33uF	M	25V	5x11		T
C3307	CEET-F470M-CI0	CAPACITOR E/ALUMINUM	47uF	M	25V	5x11		T
C3309	CEET-F470M-CI0	CAPACITOR E/ALUMINUM	47uF	M	25V	5x11		T
C3311	CEET-F470M-CI0	CAPACITOR E/ALUMINUM	47uF	M	25V	5x11		T
C3313	CEET-F470M-CI0	CAPACITOR E/ALUMINUM	47uF	M	25V	5x11		T
C3315	CEET-F470M-CI0	CAPACITOR E/ALUMINUM	47uF	M	25V	5x11		T
C3317	CEET-F470M-CI0	CAPACITOR E/ALUMINUM	47uF	M	25V	5x11		T
C3318	CEET-F470M-CI0	CAPACITOR E/ALUMINUM	47uF	M	25V	5x11		T
C3402	CEET-F470M-CI0	CAPACITOR E/ALUMINUM	47uF	M	25V	5x11		T
C3403	CEET-F470M-CI0	CAPACITOR E/ALUMINUM	47uF	M	25V	5x11		T
C3414	CEET-F470M-CI0	CAPACITOR E/ALUMINUM	47uF	M	25V	5x11		T
C3416	CEET-F470M-CI0	CAPACITOR E/ALUMINUM	47uF	M	25V	5x11		T
C353	CEET-F470M-CI0	CAPACITOR E/ALUMINUM	47uF	M	25V	5x11		T
C356	CEET-F470M-CI0	CAPACITOR E/ALUMINUM	47uF	M	25V	5x11		T
C364	CEET-F470M-CI0	CAPACITOR E/ALUMINUM	47uF	M	25V	5x11		T
C366	CEET-F470M-CI0	CAPACITOR E/ALUMINUM	47uF	M	25V	5x11		T
C3320	CEET-F470M-CI0	CAPACITOR E/ALUMINUM	47uF	M	25V	5x11		T
C3322	CEET-F470M-CI0	CAPACITOR E/ALUMINUM	47uF	M	25V	5x11		T
C349	CEET-G100M-CI0	CAPACITOR E/ALUMINUM	10uF	M	35V	5x11		T
C351	CEET-G100M-CI0	CAPACITOR E/ALUMINUM	10uF	M	35V	5x11		T
C391	CEET-G100M-CI0	CAPACITOR E/ALUMINUM	10uF	M	35V	5x11		T
C390	CEET-JR33M-CI0	CAPACITOR E/ALUMINUM	0.33uF	M	50V	5x11		T
C3303	CEET-J1R0M-CI0	CAPACITOR E/ALUMINUM	1.0uF	M	50V	5x11		T
C375	CEET-J1R0M-CI0	CAPACITOR E/ALUMINUM	1.0uF	M	50V	5x11		T
C376	CEET-J1R0M-CI0	CAPACITOR E/ALUMINUM	1.0uF	M	50V	5x11		T



## ELECTRICAL PART LIST

C377	CEET-J1R0M-CI0	CAPACITOR E/ALUMINUM	1.0uF	M	50V	5x11	T
C378	CEET-J1R0M-CI0	CAPACITOR E/ALUMINUM	1.0uF	M	50V	5x11	T
C379	CEET-J1R0M-CI0	CAPACITOR E/ALUMINUM	1.0uF	M	50V	5x11	T
C380	CEET-J1R0M-CI0	CAPACITOR E/ALUMINUM	1.0uF	M	50V	5x11	T
C384	CEET-J1R0M-CI0	CAPACITOR E/ALUMINUM	1.0uF	M	50V	5x11	T
C399	CEET-J1R0M-CI0	CAPACITOR E/ALUMINUM	1.0uF	M	50V	5x11	T
C319	CEET-J100M-CI0	CAPACITOR E/ALUMINUM	10uF	M	50V	5x11	T
C330	CEET-J100M-CI0	CAPACITOR E/ALUMINUM	10uF	M	50V	5x11	T
C350	CEET-J2R2M-CI0	CAPACITOR E/ALUMINUM	2.2uF	M	50V	5x11	T
C3411	CEET-J4R7M-CI0	CAPACITOR E/ALUMINUM	4.7uF	M	50V	5x11	T
D302	DDTS-00070-S00	DIODE-SI	1SS133	(40V 0.11A)			DO-40 T
D303	DDTS-00070-S00	DIODE-SI	1SS133	(40V 0.11A)			DO-40 T
D304	DDTS-00070-S00	DIODE-SI	1SS133	(40V 0.11A)			DO-40 T
D305	DDTS-00070-S00	DIODE-SI	1SS133	(40V 0.11A)			DO-40 T
D306	DDTS-00070-S00	DIODE-SI	1SS133	(40V 0.11A)			DO-40 T
D307	DDTS-00070-S00	DIODE-SI	1SS133	(40V 0.11A)			DO-40 T
D308	DDTS-00070-S00	DIODE-SI	1SS133	(40V 0.11A)			DO-40 T
D309	DDTS-00070-S00	DIODE-SI	1SS133	(40V 0.11A)			DO-40 T
D310	DDTS-00070-S00	DIODE-SI	1SS133	(40V 0.11A)			DO-40 T
D311	DDTS-00070-S00	DIODE-SI	1SS133	(40V 0.11A)			DO-40 T
D312	DDTS-00070-S00	DIODE-SI	1SS133	(40V 0.11A)			DO-40 T
IC301	ICAP-00410-SG0	IC 5-INPUT VIDEO SW	NJM2296M				DMP16
IC302	ICAP-00410-SG0	IC 5-INPUT VIDEO SW	NJM2296M				DMP16
IC303	ICAP-00410-SG0	IC 5-INPUT VIDEO SW	NJM2296M				DMP16
IC313	ICCM-01300-SD0	IC VOLUME CONTROL IC	KIC9459F				SOP24
IC309	ICCM-01850-S90	IC SCREEN CHAR DISPL	M35017-XXXSP/FP				
IC304	ICDG-02550-TC0	IC MULTIPLEXER	MC14053B				SOP16
IC308	ICDG-02550-TC0	IC MULTIPLEXER	MC14053B				SOP16
IC305	ICLN-04720-SB0	IC 8BIT SHIF/STORE	BU4094BC				SOP16
IC306	ICLN-04720-SB0	IC 8BIT SHIF/STORE	BU4094BC				SOP16
IC310	ICLN-04730-SB0	IC SYNC SEPARATOR	BA7046				SOP8
IC307	ICLN-04740-SB0	IC 3CHANNEL 75OHM	BA7660				SOP16
IC316	ICOP-00134-SG0	IC DUAL OP AMP	NJM4558M				SOP8
L301	KI0T-4220K-003	COIL-INDUCTOR	22uH	M	LA	50 T L	02
L302	KI0T-4220K-003	COIL-INDUCTOR	22uH	M	LA	50 T L	02
L303	KI0T-4220K-003	COIL-INDUCTOR	22uH	M	LA	50 T L	02
L304	KI0T-4220K-003	COIL-INDUCTOR	22uH	M	LA	50 T L	02
JH302	KNCW-00160-FS9	CONNECTOR-WAFER	53015-1510				2mm-WHT
JH301	KNCW-00240-DT9	CONNECTOR-WAFER	53014-13				2.0mm WHT
JW302	KNCW-00240-7T9	CONNECTOR-WAFER	53014-07				2.0mm WHT
JH303	KNCW-00760-IT0	CONNECTOR-WAFER	8370-181				1.25mm TOP 18P
L307	KORB-00090-000	CHIP FERRITE BEADS	HB-1T2012-221				
L305	KORB-00110-000	EMI BEAD FILTER	ATS3580I(MATERIAL:M3L)				
L306	KORB-00110-000	EMI BEAD FILTER	ATS3580I(MATERIAL:M3L)				
X320	KTOS-00200-358	OSCILLATOR	3.579545MHz				8PIN DIP
PCWR-02130-21L		PCB DOUBLE	A2R-213				247x197x1.6t
R3400	RCPB-B000J-21C	RESISTOR-CHIP C/FILM	0ohm		1/10W	5%	B
R3402	RCPB-B000J-21C	RESISTOR-CHIP C/FILM	0ohm		1/10W	5%	B
R301	RCPB-B100J-21C	RESISTOR-CHIP C/FILM	10ohm		1/10W	5%	B
R305	RCPB-B100J-21C	RESISTOR-CHIP C/FILM	10ohm		1/10W	5%	B
R309	RCPB-B100J-21C	RESISTOR-CHIP C/FILM	10ohm		1/10W	5%	B
R319	RCPB-B100J-21C	RESISTOR-CHIP C/FILM	10ohm		1/10W	5%	B
R3404	RCPB-B100J-21C	RESISTOR-CHIP C/FILM	10ohm		1/10W	5%	B
R3408	RCPB-B100J-21C	RESISTOR-CHIP C/FILM	10ohm		1/10W	5%	B
R360	RCPB-B100J-21C	RESISTOR-CHIP C/FILM	10ohm		1/10W	5%	B
R370	RCPB-B100J-21C	RESISTOR-CHIP C/FILM	10ohm		1/10W	5%	B
R372	RCPB-B100J-21C	RESISTOR-CHIP C/FILM	10ohm		1/10W	5%	B
R374	RCPB-B100J-21C	RESISTOR-CHIP C/FILM	10ohm		1/10W	5%	B
R3370	RCPB-B101J-21C	RESISTOR-CHIP C/FILM	100ohm		1/10W	5%	B
R3301	RCPB-B102J-21C	RESISTOR-CHIP C/FILM	1Kohm		1/10W	5%	B
R3302	RCPB-B102J-21C	RESISTOR-CHIP C/FILM	1Kohm		1/10W	5%	B
R3309	RCPB-B102J-21C	RESISTOR-CHIP C/FILM	1Kohm		1/10W	5%	B
R3374	RCPB-B102J-21C	RESISTOR-CHIP C/FILM	1Kohm		1/10W	5%	B
R3383	RCPB-B102J-21C	RESISTOR-CHIP C/FILM	1Kohm		1/10W	5%	B
R3411	RCPB-B102J-21C	RESISTOR-CHIP C/FILM	1Kohm		1/10W	5%	B



## ELECTRICAL PART LIST

R3320	RCPB-B222J-21C	RESISTOR-CHIP C/FILM	2.2Kohm	1/10W	5%	B
R3325	RCPB-B222J-21C	RESISTOR-CHIP C/FILM	2.2Kohm	1/10W	5%	B
R3326	RCPB-B222J-21C	RESISTOR-CHIP C/FILM	2.2Kohm	1/10W	5%	B
R3415	RCPB-B222J-21C	RESISTOR-CHIP C/FILM	2.2Kohm	1/10W	5%	B
R350	RCPB-B222J-21C	RESISTOR-CHIP C/FILM	2.2Kohm	1/10W	5%	B
R3500	RCPB-B222J-21C	RESISTOR-CHIP C/FILM	2.2Kohm	1/10W	5%	B
R3600	RCPB-B222J-21C	RESISTOR-CHIP C/FILM	2.2Kohm	1/10W	5%	B
R366	RCPB-B222J-21C	RESISTOR-CHIP C/FILM	2.2Kohm	1/10W	5%	B
R3372	RCPB-B3R3J-21C	RESISTOR-CHIP C/FILM	3.3ohm	1/10W	5%	B
R3406	RCPB-B330J-21C	RESISTOR-CHIP C/FILM	33ohm	1/10W	5%	B
R3407	RCPB-B330J-21C	RESISTOR-CHIP C/FILM	33ohm	1/10W	5%	B
R3417	RCPB-B330J-21C	RESISTOR-CHIP C/FILM	33ohm	1/10W	5%	B
R3418	RCPB-B330J-21C	RESISTOR-CHIP C/FILM	33ohm	1/10W	5%	B
R3376	RCPB-B331J-21C	RESISTOR-CHIP C/FILM	330ohm	1/10W	5%	B
R341	RCPB-B332J-21C	RESISTOR-CHIP C/FILM	3.3Kohm	1/10W	5%	B
R342	RCPB-B332J-21C	RESISTOR-CHIP C/FILM	3.3Kohm	1/10W	5%	B
R343	RCPB-B332J-21C	RESISTOR-CHIP C/FILM	3.3Kohm	1/10W	5%	B
R349	RCPB-B333J-21C	RESISTOR-CHIP C/FILM	33Kohm	1/10W	5%	B
R3375	RCPB-B391J-21C	RESISTOR-CHIP C/FILM	390ohm	1/10W	5%	B
R3336	RCPB-B471J-21C	RESISTOR-CHIP C/FILM	470ohm	1/10W	5%	B
R3337	RCPB-B471J-21C	RESISTOR-CHIP C/FILM	470ohm	1/10W	5%	B
R3338	RCPB-B471J-21C	RESISTOR-CHIP C/FILM	470ohm	1/10W	5%	B
R3339	RCPB-B471J-21C	RESISTOR-CHIP C/FILM	470ohm	1/10W	5%	B
R3340	RCPB-B471J-21C	RESISTOR-CHIP C/FILM	470ohm	1/10W	5%	B
R3341	RCPB-B471J-21C	RESISTOR-CHIP C/FILM	470ohm	1/10W	5%	B
R3342	RCPB-B471J-21C	RESISTOR-CHIP C/FILM	470ohm	1/10W	5%	B
R3343	RCPB-B471J-21C	RESISTOR-CHIP C/FILM	470ohm	1/10W	5%	B
R3349	RCPB-B473J-21C	RESISTOR-CHIP C/FILM	47Kohm	1/10W	5%	B
R3350	RCPB-B473J-21C	RESISTOR-CHIP C/FILM	47Kohm	1/10W	5%	B
R3354	RCPB-B473J-21C	RESISTOR-CHIP C/FILM	47Kohm	1/10W	5%	B
R356	RCPB-B473J-21C	RESISTOR-CHIP C/FILM	47Kohm	1/10W	5%	B
R3378	RCPB-B474J-21C	RESISTOR-CHIP C/FILM	470Kohm	1/10W	5%	B
R3380	RCPB-B474J-21C	RESISTOR-CHIP C/FILM	470Kohm	1/10W	5%	B
R3347	RCPB-B560J-21C	RESISTOR-CHIP C/FILM	56ohm	1/10W	5%	B
R3353	RCPB-B560J-21C	RESISTOR-CHIP C/FILM	56ohm	1/10W	5%	B
R3357	RCPB-B560J-21C	RESISTOR-CHIP C/FILM	56ohm	1/10W	5%	B
R3348	RCPB-B563J-21C	RESISTOR-CHIP C/FILM	56Kohm	1/10W	5%	B
R3351	RCPB-B563J-21C	RESISTOR-CHIP C/FILM	56Kohm	1/10W	5%	B
R3356	RCPB-B563J-21C	RESISTOR-CHIP C/FILM	56Kohm	1/10W	5%	B
R336	RCPB-B563J-21C	RESISTOR-CHIP C/FILM	56Kohm	1/10W	5%	B
R338	RCPB-B563J-21C	RESISTOR-CHIP C/FILM	56Kohm	1/10W	5%	B
R340	RCPB-B563J-21C	RESISTOR-CHIP C/FILM	56Kohm	1/10W	5%	B
R330	RCPB-B620J-21C	REGISTER-CHIP C/FILM	62ohm	1/10W	5%	B
R332	RCPB-B620J-21C	REGISTER-CHIP C/FILM	62ohm	1/10W	5%	B
R339	RCPB-B680J-21C	RESISTOR-CHIP C/FILM	68ohm	1/10W	5%	B
R334	RCPB-B680J-21C	RESISTOR-CHIP C/FILM	68ohm	1/10W	5%	B
R335	RCPB-B680J-21C	RESISTOR-CHIP C/FILM	68ohm	1/10W	5%	B
R347	RCPB-B680J-21C	RESISTOR-CHIP C/FILM	68ohm	1/10W	5%	B
R337	RCPB-B680J-21C	RESISTOR-CHIP C/FILM	68ohm	1/10W	5%	B
R361	RCPB-B680J-21C	RESISTOR-CHIP C/FILM	68ohm	1/10W	5%	B
R364	RCPB-B683J-21C	RESISTOR-CHIP C/FILM	68Kohm	1/10W	5%	B
R381	RCPB-B750J-21C	RESISTOR-CHIP C/FILM	75ohm	1/10W	5%	B
R382	RCPB-B750J-21C	RESISTOR-CHIP C/FILM	75ohm	1/10W	5%	B
R383	RCPB-B750J-21C	RESISTOR-CHIP C/FILM	75ohm	1/10W	5%	B
R387	RCPB-B750J-21C	RESISTOR-CHIP C/FILM	75ohm	1/10W	5%	B
R388	RCPB-B750J-21C	RESISTOR-CHIP C/FILM	75ohm	1/10W	5%	B
R389	RCPB-B750J-21C	RESISTOR-CHIP C/FILM	75ohm	1/10W	5%	B
R390	RCPB-B750J-21C	RESISTOR-CHIP C/FILM	75ohm	1/10W	5%	B
R391	RCPB-B750J-21C	RESISTOR-CHIP C/FILM	75ohm	1/10W	5%	B
R392	RCPB-B750J-21C	RESISTOR-CHIP C/FILM	75ohm	1/10W	5%	B
R302	RCPB-B820J-21C	RESISTOR-CHIP C/FILM	82ohm	1/10W	5%	B
R303	RCPB-B820J-21C	RESISTOR-CHIP C/FILM	82ohm	1/10W	5%	B
R304	RCPB-B820J-21C	RESISTOR-CHIP C/FILM	82ohm	1/10W	5%	B
R306	RCPB-B820J-21C	RESISTOR-CHIP C/FILM	82ohm	1/10W	5%	B
R307	RCPB-B820J-21C	RESISTOR-CHIP C/FILM	82ohm	1/10W	5%	B

## ELECTRICAL PART LIST

R308	RCPB-B820J-21C	RESISTOR-CHIP C/FILM	82ohm	1/10W	5%	B
R310	RCPB-B820J-21C	RESISTOR-CHIP C/FILM	82ohm	1/10W	5%	B
R311	RCPB-B820J-21C	RESISTOR-CHIP C/FILM	82ohm	1/10W	5%	B
R312	RCPB-B820J-21C	RESISTOR-CHIP C/FILM	82ohm	1/10W	5%	B
R314	RCPB-B820J-21C	RESISTOR-CHIP C/FILM	82ohm	1/10W	5%	B
R317	RCPB-B820J-21C	RESISTOR-CHIP C/FILM	82ohm	1/10W	5%	B
R318	RCPB-B820J-21C	RESISTOR-CHIP C/FILM	82ohm	1/10W	5%	B
R320	RCPB-B820J-21C	RESISTOR-CHIP C/FILM	82ohm	1/10W	5%	B
R321	RCPB-B820J-21C	RESISTOR-CHIP C/FILM	82ohm	1/10W	5%	B
R322	RCPB-B820J-21C	RESISTOR-CHIP C/FILM	82ohm	1/10W	5%	B
R324	RCPB-B820J-21C	RESISTOR-CHIP C/FILM	82ohm	1/10W	5%	B
R327	RCPB-B820J-21C	RESISTOR-CHIP C/FILM	82ohm	1/10W	5%	B
R328	RCPB-B820J-21C	RESISTOR-CHIP C/FILM	82ohm	1/10W	5%	B
R3303	RCPB-B821J-21C	RESISTOR-CHIP C/FILM	820ohm	1/10W	5%	B
R3311	RCPB-B821J-21C	RESISTOR-CHIP C/FILM	820ohm	1/10W	5%	B
R3316	RCPB-B821J-21C	RESISTOR-CHIP C/FILM	820ohm	1/10W	5%	B
R3317	RCPB-B821J-21C	RESISTOR-CHIP C/FILM	820ohm	1/10W	5%	B
R3322	RCPB-B821J-21C	RESISTOR-CHIP C/FILM	820ohm	1/10W	5%	B
R3323	RCPB-B821J-21C	RESISTOR-CHIP C/FILM	820ohm	1/10W	5%	B
R3328	RCPB-B821J-21C	RESISTOR-CHIP C/FILM	820ohm	1/10W	5%	B
R3355	RCPB-B821J-21C	RESISTOR-CHIP C/FILM	820ohm	1/10W	5%	B
R363	RCPB-B822J-21C	RESISTOR-CHIP C/FILM	8.2Kohm	1/10W	5%	B
R365	RCPB-B822J-21C	RESISTOR-CHIP C/FILM	8.2Kohm	1/10W	5%	B
R378	RCPB-B824J-21C	RESISTOR-CHIP C/FILM	820Kohm	1/10W	5%	B
R379	RCPB-B824J-21C	RESISTOR-CHIP C/FILM	820Kohm	1/10W	5%	B
R380	RCPB-B824J-21C	RESISTOR-CHIP C/FILM	820Kohm	1/10W	5%	B
JW320	RJWT-00000-AA0	RESISTOR-JUMPER WIRE	60mm-TX123	F		
JW321	RJWT-00000-AA0	RESISTOR-JUMPER WIRE	60mm-TX123	F		
JW331	RJWT-00000-AA0	RESISTOR-JUMPER WIRE	60mm-TX123	F		
JW332	RJWT-00000-AA0	RESISTOR-JUMPER WIRE	60mm-TX123	F		
JW347	RJWT-00000-AA0	RESISTOR-JUMPER WIRE	60mm-TX123	F		
JW348	RJWT-00000-AA0	RESISTOR-JUMPER WIRE	60mm-TX123	F		
JK310	SKRC-00612-03P	PIN JACK BOARD	JE030039EG			
JK312	SKRC-00612-03P	PIN JACK BOARD	JE030039EG			
JK313	SKRC-00612-03P	PIN JACK BOARD	JE030039EG			
JK301	SKRC-00881-000	PIN JACK BOARD	C5016031JG			
JK302	SKRC-00881-000	PIN JACK BOARD	C5016031JG			
JK303	SKRC-00881-000	PIN JACK BOARD	C5016031JG			
JK304	SKRC-00881-000	PIN JACK BOARD	C5016031JG			
JK305	SKRC-00881-000	PIN JACK BOARD	C5016031JG			
JK306	SKRC-00881-000	PIN JACK BOARD	C5016031JG			
JK308	SKRC-00881-000	PIN JACK BOARD	C5016031JG			
JK315	SKRC-01274-02P	PIN JACK BOARD	JS020056KG			
JK316	SKRC-01275-02P	PIN JACK BOARD	JS020056LG			
JK317	SKRC-01276-02P	PIN JACK BOARD	JS020056QG			
JK318	SKRC-01277-02P	PIN JACK BOARD	JS020056MG			
JK321	SKRC-01292-04P	PIN JACK BOARD	JE040171MG			
JK320	SKRC-01293-04P	PIN JACK BOARD	JE040171LG			
Q334	TRBC-01770-SD0	TRANSISTOR N-H FREQ	KTC3875	SOT-23		
Q335	TRBC-01770-SD0	TRANSISTOR N-H FREQ	KTC3875	SOT-23		
Q336	TRBC-01770-SD0	TRANSISTOR N-H FREQ	KTC3875	SOT-23		
Q325	TRSA-01360-SD0	TRANSISTOR P-H FREQ	KRA107S	SOT-23		
Q314	TRTA-0008G-SD0	TRANSISTOR P-H FREQ	KTA1266-GR		TO92	
Q317	TRTA-0008G-SD0	TRANSISTOR P-H FREQ	KTA1266-GR		TO92	
Q318	TRTA-0008G-SD0	TRANSISTOR P-H FREQ	KTA1266-GR		TO92	
Q319	TRTA-0008G-SD0	TRANSISTOR P-H FREQ	KTA1266-GR		TO92	
Q322	TRTA-0008G-SD0	TRANSISTOR P-H FREQ	KTA1266-GR		TO92	
Q301	TRTA-00820-SB0	TRANSISTOR P-H FREQ	2SA933AS	SPT		
Q302	TRTA-00940-SD0	TRANSISTOR P-H FREQ	KRA107M	W/RESIST	TO92M	
Q311	TRTA-00940-SD0	TRANSISTOR P-H FREQ	KRA107M	W/RESIST	TO92M	
Q304	TRTC-0002B-SD0	TRANSISTOR TO92	KTC2874	(TO92)		
Q305	TRTC-0002B-SD0	TRANSISTOR TO92	KTC2874	(TO92)		
Q306	TRTC-0002B-SD0	TRANSISTOR TO92	KTC2874	(TO92)		
Q307	TRTC-0002B-SD0	TRANSISTOR TO92	KTC2874	(TO92)		
Q313	TRTC-0002B-SD0	TRANSISTOR TO92	KTC2874	(TO92)		

## ELECTRICAL PART LIST

Q315	TRTC-0016G-SD0	TRANSISTOR N-H FREQ	KTC3198-GR	TO92
Q316	TRTC-0016G-SD0	TRANSISTOR N-H FREQ	KTC3198-GR	TO92
Q324	TRTC-01090-SB0	TRANSISTOR N-H FREQ	DTC114YSA	W/RESIST SPT
Q303	TRTC-01700-SD0	TRANSISTOR N-H FREQ	KRC107M	W/RESIST TO92M
Q308	TRTC-01700-SD0	TRANSISTOR N-H FREQ	KRC107M	W/RESIST TO92M
Q309	TRTC-01700-SD0	TRANSISTOR N-H FREQ	KRC107M	W/RESIST TO92M
Q310	TRTC-01700-SD0	TRANSISTOR N-H FREQ	KRC107M	W/RESIST TO92M
Q320	TRTC-01700-SD0	TRANSISTOR N-H FREQ	KRC107M	W/RESIST TO92M
Q321	TRTC-01700-SD0	TRANSISTOR N-H FREQ	KRC107M	W/RESIST TO92M
Q323	TRTC-01700-SD0	TRANSISTOR N-H FREQ	KRC107M	W/RESIST TO92M
Q312	TRTD-00200-SD0	TRANSISTOR N-L FREQ	KTD-1302	TO92
Q326	TRTD-00200-SD0	TRANSISTOR N-L FREQ	KTD-1302	TO92
Q327	TRTD-00200-SD0	TRANSISTOR N-L FREQ	KTD-1302	TO92
Q328	TRTD-00200-SD0	TRANSISTOR N-L FREQ	KTD-1302	TO92
Q329	TRTD-00200-SD0	TRANSISTOR N-L FREQ	KTD-1302	TO92
Q330	TRTD-00200-SD0	TRANSISTOR N-L FREQ	KTD-1302	TO92
Q331	TRTD-00200-SD0	TRANSISTOR N-L FREQ	KTD-1302	TO92
Q332	TRTD-00200-SD0	TRANSISTOR N-L FREQ	KTD-1302	TO92
Q333	TRTD-00200-SD0	TRANSISTOR N-L FREQ	KTD-1302	TO92
JW301	UM08-F1075-000	WIRE-ASS'Y	1533/2547#28	GRY-160 15P
	U1T1-0G514-Z10	WIRE-ASS'Y	HIGH WRAP#22	BLK-140 1P
JW303	U808-80819-250	WIRE-ASS'Y	1533#28	GRY-190 8P

**PWM/DSP**

LOCNUM	SONITM	MATDES	MATSPC
C1233	CACS-S472M-180	CAPACITOR AC	DE7150 F472MVA1 250V BS415
C1238	CCAT-J104Z-AAF	CAPACITOR CERAMIC	0.1uF Z 50V F T
C1203	CCMB-F102K-0AB	CAPACITOR CHIP/MULT	1000PF K 25V B B
C1204	CCMB-F102K-0AB	CAPACITOR CHIP/MULT	1000PF K 25V B B
C1205	CCMB-F102K-0AB	CAPACITOR CHIP/MULT	1000PF K 25V B B
C1206	CCMB-F102K-0AB	CAPACITOR CHIP/MULT	1000PF K 25V B B
C1207	CCMB-F102K-0AB	CAPACITOR CHIP/MULT	1000PF K 25V B B
C1208	CCMB-F102K-0AB	CAPACITOR CHIP/MULT	1000PF K 25V B B
C1209	CCMB-F102K-0AB	CAPACITOR CHIP/MULT	1000PF K 25V B B
C1210	CCMB-F102K-0AB	CAPACITOR CHIP/MULT	1000PF K 25V B B
C1080	CCMB-F103K-0AB	CAPACITOR CHIP/MULT	0.01uF K 25V B B
C1082	CCMB-F103K-0AB	CAPACITOR CHIP/MULT	0.01uF K 25V B B
C1113	CCMB-F103K-0AB	CAPACITOR CHIP/MULT	0.01uF K 25V B B
C1226	CCMB-F103K-0AB	CAPACITOR CHIP/MULT	0.01uF K 25V B B
C1072	CCMB-F104Z-0AF	CAPACITOR CHIP/MULT	0.1uF Z 25V F B
C1074	CCMB-F104Z-0AF	CAPACITOR CHIP/MULT	0.1uF Z 25V F B
C1076	CCMB-F104Z-0AF	CAPACITOR CHIP/MULT	0.1uF Z 25V F B
C1077	CCMB-F104Z-0AF	CAPACITOR CHIP/MULT	0.1uF Z 25V F B
C1078	CCMB-F104Z-0AF	CAPACITOR CHIP/MULT	0.1uF Z 25V F B
C1081	CCMB-F104Z-0AF	CAPACITOR CHIP/MULT	0.1uF Z 25V F B
C1085	CCMB-F104Z-0AF	CAPACITOR CHIP/MULT	0.1uF Z 25V F B
C1087	CCMB-F104Z-0AF	CAPACITOR CHIP/MULT	0.1uF Z 25V F B
C1089	CCMB-F104Z-0AF	CAPACITOR CHIP/MULT	0.1uF Z 25V F B
C1095	CCMB-F104Z-0AF	CAPACITOR CHIP/MULT	0.1uF Z 25V F B
C1096	CCMB-F104Z-0AF	CAPACITOR CHIP/MULT	0.1uF Z 25V F B
C1097	CCMB-F104Z-0AF	CAPACITOR CHIP/MULT	0.1uF Z 25V F B
C1098	CCMB-F104Z-0AF	CAPACITOR CHIP/MULT	0.1uF Z 25V F B
C1099	CCMB-F104Z-0AF	CAPACITOR CHIP/MULT	0.1uF Z 25V F B
C1100	CCMB-F104Z-0AF	CAPACITOR CHIP/MULT	0.1uF Z 25V F B
C1102	CCMB-F104Z-0AF	CAPACITOR CHIP/MULT	0.1uF Z 25V F B
C1103	CCMB-F104Z-0AF	CAPACITOR CHIP/MULT	0.1uF Z 25V F B
C1106	CCMB-F104Z-0AF	CAPACITOR CHIP/MULT	0.1uF Z 25V F B
C1108	CCMB-F104Z-0AF	CAPACITOR CHIP/MULT	0.1uF Z 25V F B
C1109	CCMB-F104Z-0AF	CAPACITOR CHIP/MULT	0.1uF Z 25V F B
C1112	CCMB-F104Z-0AF	CAPACITOR CHIP/MULT	0.1uF Z 25V F B
C1116	CCMB-F104Z-0AF	CAPACITOR CHIP/MULT	0.1uF Z 25V F B
C1117	CCMB-F104Z-0AF	CAPACITOR CHIP/MULT	0.1uF Z 25V F B
C1119	CCMB-F104Z-0AF	CAPACITOR CHIP/MULT	0.1uF Z 25V F B
C1121	CCMB-F104Z-0AF	CAPACITOR CHIP/MULT	0.1uF Z 25V F B
C1123	CCMB-F104Z-0AF	CAPACITOR CHIP/MULT	0.1uF Z 25V F B
C1125	CCMB-F104Z-0AF	CAPACITOR CHIP/MULT	0.1uF Z 25V F B





## ELECTRICAL PART LIST

C989	CCMB-J104K-0BB	CAPACITOR CHIP/MULT	0.1uF	K 50V	X7R B
C990	CCMB-J104K-0BB	CAPACITOR CHIP/MULT	0.1uF	K 50V	X7R B
C991	CCMB-J104K-0BB	CAPACITOR CHIP/MULT	0.1uF	K 50V	X7R B
C992	CCMB-J104K-0BB	CAPACITOR CHIP/MULT	0.1uF	K 50V	X7R B
C993	CCMB-J104K-0BB	CAPACITOR CHIP/MULT	0.1uF	K 50V	X7R B
C994	CCMB-J104K-0BB	CAPACITOR CHIP/MULT	0.1uF	K 50V	X7R B
C995	CCMB-J104K-0BB	CAPACITOR CHIP/MULT	0.1uF	K 50V	X7R B
C996	CCMB-J104K-0BB	CAPACITOR CHIP/MULT	0.1uF	K 50V	X7R B
C997	CCMB-J104K-0BB	CAPACITOR CHIP/MULT	0.1uF	K 50V	X7R B
C998	CCMB-J104K-0BB	CAPACITOR CHIP/MULT	0.1uF	K 50V	X7R B
C999	CCMB-J104K-0BB	CAPACITOR CHIP/MULT	0.1uF	K 50V	X7R B
C1199	CCMB-J152K-0AG	CAPACITOR CHIP/MULT	GRM39X7R152K50PT/1.5N		
C1200	CCMB-J152K-0AG	CAPACITOR CHIP/MULT	GRM39X7R152K50PT/1.5N		
C1201	CCMB-J152K-0AG	CAPACITOR CHIP/MULT	GRM39X7R152K50PT/1.5N		
C1202	CCMB-J152K-0AG	CAPACITOR CHIP/MULT	GRM39X7R152K50PT/1.5N		
C1264	CCMB-J180J-0AC	CAPACITOR CHIP/MULT	18PF	J 50V	CH B
C1265	CCMB-J180J-0AC	CAPACITOR CHIP/MULT	18PF	J 50V	CH B
C913	CCMB-J180J-0AC	CAPACITOR CHIP/MULT	18PF	J 50V	CH B
C914	CCMB-J180J-0AC	CAPACITOR CHIP/MULT	18PF	J 50V	CH B
C925	CCMB-J180J-0AC	CAPACITOR CHIP/MULT	18PF	J 50V	CH B
C926	CCMB-J180J-0AC	CAPACITOR CHIP/MULT	18PF	J 50V	CH B
C1227	CCMB-J220J-0AC	CAPACITOR CHIP/MULT	22PF	J 50V	CH B
C1012	CCMB-J223K-0BB	CAPACITOR CHIP/MULT	0.022uF	K 50V	X7R B
C1013	CCMB-J223K-0BB	CAPACITOR CHIP/MULT	0.022uF	K 50V	X7R B
C1014	CCMB-J223K-0BB	CAPACITOR CHIP/MULT	0.022uF	K 50V	X7R B
C1015	CCMB-J223K-0BB	CAPACITOR CHIP/MULT	0.022uF	K 50V	X7R B
C1016	CCMB-J223K-0BB	CAPACITOR CHIP/MULT	0.022uF	K 50V	X7R B
C1017	CCMB-J223K-0BB	CAPACITOR CHIP/MULT	0.022uF	K 50V	X7R B
C1018	CCMB-J223K-0BB	CAPACITOR CHIP/MULT	0.022uF	K 50V	X7R B
C1019	CCMB-J223K-0BB	CAPACITOR CHIP/MULT	0.022uF	K 50V	X7R B
C1020	CCMB-J223K-0BB	CAPACITOR CHIP/MULT	0.022uF	K 50V	X7R B
C1021	CCMB-J223K-0BB	CAPACITOR CHIP/MULT	0.022uF	K 50V	X7R B
C1022	CCMB-J223K-0BB	CAPACITOR CHIP/MULT	0.022uF	K 50V	X7R B
C1023	CCMB-J223K-0BB	CAPACITOR CHIP/MULT	0.022uF	K 50V	X7R B
C1024	CCMB-J223K-0BB	CAPACITOR CHIP/MULT	0.022uF	K 50V	X7R B
C1025	CCMB-J223K-0BB	CAPACITOR CHIP/MULT	0.022uF	K 50V	X7R B
C1219	CCMB-J331K-0BB	CAPACITOR CHIP/MULT	330PF	K 50V	X7R B
C1220	CCMB-J331K-0BB	CAPACITOR CHIP/MULT	330PF	K 50V	X7R B
C1221	CCMB-J331K-0BB	CAPACITOR CHIP/MULT	330PF	K 50V	X7R B
C1222	CCMB-J331K-0BB	CAPACITOR CHIP/MULT	330PF	K 50V	X7R B
C1223	CCMB-J331K-0BB	CAPACITOR CHIP/MULT	330PF	K 50V	X7R B
C1224	CCMB-J331K-0BB	CAPACITOR CHIP/MULT	330PF	K 50V	X7R B
C1225	CCMB-J331K-0BB	CAPACITOR CHIP/MULT	330PF	K 50V	X7R B
C1042	CCMB-J332K-0AG	CAPACITOR CHIP/MULT	GRM39X7R332K50PT/3.3N		
C1043	CCMB-J332K-0AG	CAPACITOR CHIP/MULT	GRM39X7R332K50PT/3.3N		
C1050	CCMB-J332K-0AG	CAPACITOR CHIP/MULT	GRM39X7R332K50PT/3.3N		
C1051	CCMB-J332K-0AG	CAPACITOR CHIP/MULT	GRM39X7R332K50PT/3.3N		
C1059	CCMB-J332K-0AG	CAPACITOR CHIP/MULT	GRM39X7R332K50PT/3.3N		
C1069	CCMB-J332K-0AG	CAPACITOR CHIP/MULT	GRM39X7R332K50PT/3.3N		
C1070	CCMB-J332K-0AG	CAPACITOR CHIP/MULT	GRM39X7R332K50PT/3.3N		
C1215	CCMB-J332K-0AG	CAPACITOR CHIP/MULT	GRM39X7R332K50PT/3.3N		
C1216	CCMB-J332K-0AG	CAPACITOR CHIP/MULT	GRM39X7R332K50PT/3.3N		
C1217	CCMB-J332K-0AG	CAPACITOR CHIP/MULT	GRM39X7R332K50PT/3.3N		
C1218	CCMB-J332K-0AG	CAPACITOR CHIP/MULT	GRM39X7R332K50PT/3.3N		
C1150	CCMB-J470J-0AC	CAPACITOR CHIP/MULT	47PF	J 50V	CH B
C1151	CCMB-J470J-0AC	CAPACITOR CHIP/MULT	47PF	J 50V	CH B
C1152	CCMB-J470J-0AC	CAPACITOR CHIP/MULT	47PF	J 50V	CH B
C1153	CCMB-J470J-0AC	CAPACITOR CHIP/MULT	47PF	J 50V	CH B
C1158	CCMB-J470J-0AC	CAPACITOR CHIP/MULT	47PF	J 50V	CH B
C1159	CCMB-J470J-0AC	CAPACITOR CHIP/MULT	47PF	J 50V	CH B
C1160	CCMB-J470J-0AC	CAPACITOR CHIP/MULT	47PF	J 50V	CH B
C1161	CCMB-J470J-0AC	CAPACITOR CHIP/MULT	47PF	J 50V	CH B
C1166	CCMB-J470J-0AC	CAPACITOR CHIP/MULT	47PF	J 50V	CH B
C1167	CCMB-J470J-0AC	CAPACITOR CHIP/MULT	47PF	J 50V	CH B
C1168	CCMB-J470J-0AC	CAPACITOR CHIP/MULT	47PF	J 50V	CH B



## ELECTRICAL PART LIST

C1169	CCMB-J470J-0AC	CAPACITOR CHIP/MULT	47PF	J 50V	CH	B	
C1174	CCMB-J470J-0AC	CAPACITOR CHIP/MULT	47PF	J 50V	CH	B	
C1175	CCMB-J470J-0AC	CAPACITOR CHIP/MULT	47PF	J 50V	CH	B	
C1176	CCMB-J470J-0AC	CAPACITOR CHIP/MULT	47PF	J 50V	CH	B	
C1177	CCMB-J470J-0AC	CAPACITOR CHIP/MULT	47PF	J 50V	CH	B	
C1243	CCMB-J470J-0AC	CAPACITOR CHIP/MULT	47PF	J 50V	CH	B	
C1244	CCMB-J470J-0AC	CAPACITOR CHIP/MULT	47PF	J 50V	CH	B	
C1245	CCMB-J470J-0AC	CAPACITOR CHIP/MULT	47PF	J 50V	CH	B	
C1246	CCMB-J470J-0AC	CAPACITOR CHIP/MULT	47PF	J 50V	CH	B	
C1115	CCMB-J471J-0AZ	CAPACITOR CHIP/MULT	470PF	J 50V	SL	B	
C1038	CCMB-J561J-0AZ	CAPACITOR CHIP/MULT	560PF	J 50V	SL	B	
C1039	CCMB-J561J-0AZ	CAPACITOR CHIP/MULT	560PF	J 50V	SL	B	
C1046	CCMB-J561J-0AZ	CAPACITOR CHIP/MULT	560PF	J 50V	SL	B	
C1047	CCMB-J561J-0AZ	CAPACITOR CHIP/MULT	560PF	J 50V	SL	B	
C1052	CCMB-J561J-0AZ	CAPACITOR CHIP/MULT	560PF	J 50V	SL	B	
C1054	CCMB-J561J-0AZ	CAPACITOR CHIP/MULT	560PF	J 50V	SL	B	
C1055	CCMB-J561J-0AZ	CAPACITOR CHIP/MULT	560PF	J 50V	SL	B	
C1065	CCMB-J561J-0AZ	CAPACITOR CHIP/MULT	560PF	J 50V	SL	B	
C1066	CCMB-J561J-0AZ	CAPACITOR CHIP/MULT	560PF	J 50V	SL	B	
C901	CEES-J102J-LP1	CAPACITOR E/ALUMINUM	1000uF/50V				
C951	CEES-J102J-LP1	CAPACITOR E/ALUMINUM	1000uF/50V				
C956	CEES-J102J-LP1	CAPACITOR E/ALUMINUM	1000uF/50V				
C961	CEES-J102J-LP1	CAPACITOR E/ALUMINUM	1000uF/50V				
C966	CEES-J102J-LP1	CAPACITOR E/ALUMINUM	1000uF/50V				
C1101	CEET-C102M-HJ1	CAPACITOR E/ALUMINUM	1000uF	6.3V	10x12.5	SMS	T
C1104	CEET-C102M-HJ1	CAPACITOR E/ALUMINUM	1000uF	6.3V	10x12.5	SMS	T
C903	CEET-C102M-HJ1	CAPACITOR E/ALUMINUM	1000uF	6.3V	10x12.5	SMS	T
C905	CEET-C102M-HJ1	CAPACITOR E/ALUMINUM	1000uF	6.3V	10x12.5	SMS	T
C1118	CEET-C331M-CI0	CAPACITOR E/ALUMINUM	330uF	M 6.3V	6.3x11		T
C1120	CEET-C331M-CI0	CAPACITOR E/ALUMINUM	330uF	M 6.3V	6.3x11		T
C1122	CEET-C331M-CI0	CAPACITOR E/ALUMINUM	330uF	M 6.3V	6.3x11		T
C1124	CEET-C331M-CI0	CAPACITOR E/ALUMINUM	330uF	M 6.3V	6.3x11		T
C1126	CEET-C331M-CI0	CAPACITOR E/ALUMINUM	330uF	M 6.3V	6.3x11		T
C1128	CEET-C331M-CI0	CAPACITOR E/ALUMINUM	330uF	M 6.3V	6.3x11		T
C1130	CEET-C331M-CI0	CAPACITOR E/ALUMINUM	330uF	M 6.3V	6.3x11		T
C1132	CEET-C331M-CI0	CAPACITOR E/ALUMINUM	330uF	M 6.3V	6.3x11		T
C1253	CEET-C331M-CI0	CAPACITOR E/ALUMINUM	330uF	M 6.3V	6.3x11		T
C1254	CEET-C331M-CI0	CAPACITOR E/ALUMINUM	330uF	M 6.3V	6.3x11		T
C1105	CEET-D101M-CI0	CAPACITOR E/ALUMINUM	100uF	M 10V	5x11		T
C1107	CEET-D101M-CI0	CAPACITOR E/ALUMINUM	100uF	M 10V	5x11		T
C1110	CEET-D101M-CI0	CAPACITOR E/ALUMINUM	100uF	M 10V	5x11		T
C1114	CEET-D101M-CI0	CAPACITOR E/ALUMINUM	100uF	M 10V	5x11		T
C1188	CEET-D101M-CI0	CAPACITOR E/ALUMINUM	100uF	M 10V	5x11		T
C1194	CEET-D101M-CI0	CAPACITOR E/ALUMINUM	100uF	M 10V	5x11		T
C1026	CEET-E100M-CI0	CAPACITOR E/ALUMINUM	10uF	M 16V	5x11		T
C1027	CEET-E100M-CI0	CAPACITOR E/ALUMINUM	10uF	M 16V	5x11		T
C1028	CEET-E100M-CI0	CAPACITOR E/ALUMINUM	10uF	M 16V	5x11		T
C1029	CEET-E100M-CI0	CAPACITOR E/ALUMINUM	10uF	M 16V	5x11		T
C1030	CEET-E100M-CI0	CAPACITOR E/ALUMINUM	10uF	M 16V	5x11		T
C1031	CEET-E100M-CI0	CAPACITOR E/ALUMINUM	10uF	M 16V	5x11		T
C1032	CEET-E100M-CI0	CAPACITOR E/ALUMINUM	10uF	M 16V	5x11		T
C1033	CEET-E100M-CI0	CAPACITOR E/ALUMINUM	10uF	M 16V	5x11		T
C1062	CEET-E100M-CI0	CAPACITOR E/ALUMINUM	10uF	M 16V	5x11		T
C1071	CEET-E100M-CI0	CAPACITOR E/ALUMINUM	10uF	M 16V	5x11		T
C1073	CEET-E100M-CI0	CAPACITOR E/ALUMINUM	10uF	M 16V	5x11		T
C1079	CEET-E100M-CI0	CAPACITOR E/ALUMINUM	10uF	M 16V	5x11		T
C1156	CEET-E100M-CI0	CAPACITOR E/ALUMINUM	10uF	M 16V	5x11		T
C1157	CEET-E100M-CI0	CAPACITOR E/ALUMINUM	10uF	M 16V	5x11		T
C1164	CEET-E100M-CI0	CAPACITOR E/ALUMINUM	10uF	M 16V	5x11		T
C1165	CEET-E100M-CI0	CAPACITOR E/ALUMINUM	10uF	M 16V	5x11		T
C1172	CEET-E100M-CI0	CAPACITOR E/ALUMINUM	10uF	M 16V	5x11		T
C1173	CEET-E100M-CI0	CAPACITOR E/ALUMINUM	10uF	M 16V	5x11		T
C1180	CEET-E100M-CI0	CAPACITOR E/ALUMINUM	10uF	M 16V	5x11		T
C1181	CEET-E100M-CI0	CAPACITOR E/ALUMINUM	10uF	M 16V	5x11		T
C1182	CEET-E100M-CI0	CAPACITOR E/ALUMINUM	10uF	M 16V	5x11		T
C1195	CEET-E100M-CI0	CAPACITOR E/ALUMINUM	10uF	M 16V	5x11		T
C1196	CEET-E100M-CI0	CAPACITOR E/ALUMINUM	10uF	M 16V	5x11		T

## ELECTRICAL PART LIST

C1197	CEET-E100M-CI0	CAPACITOR E/ALUMINUM	10uF	M	16V	5x11	T
C1198	CEET-E100M-CI0	CAPACITOR E/ALUMINUM	10uF	M	16V	5x11	T
C1211	CEET-E100M-CI0	CAPACITOR E/ALUMINUM	10uF	M	16V	5x11	T
C1212	CEET-E100M-CI0	CAPACITOR E/ALUMINUM	10uF	M	16V	5x11	T
C1213	CEET-E100M-CI0	CAPACITOR E/ALUMINUM	10uF	M	16V	5x11	T
C1214	CEET-E100M-CI0	CAPACITOR E/ALUMINUM	10uF	M	16V	5x11	T
C1256	CEET-E100M-CI0	CAPACITOR E/ALUMINUM	10uF	M	16V	5x11	T
C1257	CEET-E100M-CI0	CAPACITOR E/ALUMINUM	10uF	M	16V	5x11	T
C1034	CEET-F470M-CI0	CAPACITOR E/ALUMINUM	47uF	M	25V	5x11	T
C1035	CEET-F470M-CI0	CAPACITOR E/ALUMINUM	47uF	M	25V	5x11	T
C1075	CEET-F470M-CI0	CAPACITOR E/ALUMINUM	47uF	M	25V	5x11	T
C1142	CEET-F470M-CI0	CAPACITOR E/ALUMINUM	47uF	M	25V	5x11	T
C1143	CEET-F470M-CI0	CAPACITOR E/ALUMINUM	47uF	M	25V	5x11	T
C1144	CEET-F470M-CI0	CAPACITOR E/ALUMINUM	47uF	M	25V	5x11	T
C1145	CEET-F470M-CI0	CAPACITOR E/ALUMINUM	47uF	M	25V	5x11	T
C1146	CEET-F470M-CI0	CAPACITOR E/ALUMINUM	47uF	M	25V	5x11	T
C1147	CEET-F470M-CI0	CAPACITOR E/ALUMINUM	47uF	M	25V	5x11	T
C1148	CEET-F470M-CI0	CAPACITOR E/ALUMINUM	47uF	M	25V	5x11	T
C1149	CEET-F470M-CI0	CAPACITOR E/ALUMINUM	47uF	M	25V	5x11	T
C1230	CEET-F470M-CI0	CAPACITOR E/ALUMINUM	47uF	M	25V	5x11	T
C1231	CEET-F470M-CI0	CAPACITOR E/ALUMINUM	47uF	M	25V	5x11	T
C1247	CEET-F470M-CI0	CAPACITOR E/ALUMINUM	47uF	M	25V	5x11	T
C1248	CEET-F470M-CI0	CAPACITOR E/ALUMINUM	47uF	M	25V	5x11	T
C1084	CEET-G100M-CI0	CAPACITOR E/ALUMINUM	10uF	M	35V	5x11	T
C1086	CEET-G100M-CI0	CAPACITOR E/ALUMINUM	10uF	M	35V	5x11	T
C1088	CEET-G100M-CI0	CAPACITOR E/ALUMINUM	10uF	M	35V	5x11	T
C1083	CEET-JR47M-CI0	CAPACITOR E/ALUMINUM	0.47uF	M	50V	5x11	T
C1184	CEET-J1R0M-CI0	CAPACITOR E/ALUMINUM	1.0uF	M	50V	5x11	T
C1186	CEET-J1R0M-CI0	CAPACITOR E/ALUMINUM	1.0uF	M	50V	5x11	T
C1190	CEET-J1R0M-CI0	CAPACITOR E/ALUMINUM	1.0uF	M	50V	5x11	T
C1192	CEET-J1R0M-CI0	CAPACITOR E/ALUMINUM	1.0uF	M	50V	5x11	T
C1111	CEET-J2R2M-CI0	CAPACITOR E/ALUMINUM	2.2uF	M	50V	5x11	T
C1260	CETB-C2R2M-0E0	CAPACITOR CHIPTANTAL	2.2uF	6.3V	20% A		
C909	CETB-C2R2M-0E0	CAPACITOR CHIPTANTAL	2.2uF	6.3V	20% A		
C920	CETB-C2R2M-0E0	CAPACITOR CHIPTANTAL	2.2uF	6.3V	20% A		
C1266	CETB-C220M-0E0	CAPACITOR CHIPTANTAL	22uF	6.3V	A TSM0J226ASSR		
C915	CETB-C220M-0E0	CAPACITOR CHIPTANTAL	22uF	6.3V	A TSM0J226ASSR		
C927	CETB-C220M-0E0	CAPACITOR CHIPTANTAL	22uF	6.3V	A TSM0J226ASSR		
C952	CETB-J1R0M-0H0	CAPACITOR CHIPTANTAL	1uF	50V	20% 6032		
C954	CETB-J1R0M-0H0	CAPACITOR CHIPTANTAL	1uF	50V	20% 6032		
C957	CETB-J1R0M-0H0	CAPACITOR CHIPTANTAL	1uF	50V	20% 6032		
C959	CETB-J1R0M-0H0	CAPACITOR CHIPTANTAL	1uF	50V	20% 6032		
C962	CETB-J1R0M-0H0	CAPACITOR CHIPTANTAL	1uF	50V	20% 6032		
C964	CETB-J1R0M-0H0	CAPACITOR CHIPTANTAL	1uF	50V	20% 6032		
C967	CETB-J1R0M-0H0	CAPACITOR CHIPTANTAL	1uF	50V	20% 6032		
C969	CETB-J1R0M-0H0	CAPACITOR CHIPTANTAL	1uF	50V	20% 6032		
C1005	CFMT-J474J-DF0	CAPACITOR F/POLYESTR	0.47uF	J	50V	6x8	TL
C1006	CFMT-J474J-DF0	CAPACITOR F/POLYESTR	0.47uF	J	50V	6x8	TL
C1007	CFMT-J474J-DF0	CAPACITOR F/POLYESTR	0.47uF	J	50V	6x8	TL
C1008	CFMT-J474J-DF0	CAPACITOR F/POLYESTR	0.47uF	J	50V	6x8	TL
C1009	CFMT-J474J-DF0	CAPACITOR F/POLYESTR	0.47uF	J	50V	6x8	TL
C1010	CFMT-J474J-DF0	CAPACITOR F/POLYESTR	0.47uF	J	50V	6x8	TL
C1011	CFMT-J474J-DF0	CAPACITOR F/POLYESTR	0.47uF	J	50V	6x8	TL
D902	DDTR-00040-T10	DIODE-RECTIFIER	1N4004S(400V	1A	0.6mm)		T
D903	DDTR-00040-T10	DIODE-RECTIFIER	1N4004S(400V	1A	0.6mm)		T
D901	DDTS-00070-S00	DIODE-SI	1SS133 (40V	0.11A)	DO-40		T
RL902	ESRY-00410-500	POWER RELAY	DQ5D1-0(M)DC5V				
RL901	ESRY-00451-100	RELAY	TSC-105L3H	5V	100mA		
IC904	ICAP-00500-000	IC AMP-POWER	DDX-2100				
IC905	ICAP-00500-000	IC AMP-POWER	DDX-2100				
IC906	ICAP-00500-000	IC AMP-POWER	DDX-2100				
IC907	ICAP-00500-000	IC AMP-POWER	DDX-2100				
IC910	ICCM-01641-V60	IC EEPROM	SST39VF040-90(70)-4C-NH				
IC916	ICCM-01960-S70	IC OCTAL BUFFER LINE	74HC244D(R)		SOP20		
IC911	ICCM-01970-S70	IC OCTAL D-TYPE F/F	74LVC574AD(R)		SOP20		
IC912	ICCM-01970-S70	IC OCTAL D-TYPE F/F	74LVC574AD(R)		SOP20		
IC936	ICDG-02310-US0	IC D/A CONVERTER	CS4340-KS				

## ELECTRICAL PART LIST

IC937	ICDG-02310-US0	IC D/A CONVERTER	CS4340-KS
IC918	ICDG-02320-US0	IC A/D CONVERTER	CS5360-KS
IC919	ICDG-02320-US0	IC A/D CONVERTER	CS5360-KS
IC920	ICDG-02320-US0	IC A/D CONVERTER	CS5360-KS
IC921	ICDG-02320-US0	IC A/D CONVERTER	CS5360-KS
IC942	ICDG-02320-US0	IC A/D CONVERTER	CS5360-KS
IC913	ICDG-02420-US0	DSP IC	CS49326
IC930	ICDG-02900-U40	IC DIGITAL AUDIO	AK4114VQ LQFP44P
IC908	ICDG-02940-US0	IC 114DB D/A CONVERT	CS4382-KQ LQFP48
IC915	ICDG-02960-WE0	IC PLD	M4A3-32/32-10VC44 TQFP44
IC901	ICDG-03130-000	IC DIGITAL AUDIO	DDX4100A
IC902	ICDG-03130-000	IC DIGITAL AUDIO	DDX4100A
IC944	ICDG-03130-000	IC DIGITAL AUDIO	DDX4100A
IC922	ICOP-00134-SG0	IC DUAL OP AMP	NJM4558M SOP8
IC923	ICOP-00134-SG0	IC DUAL OP AMP	NJM4558M SOP8
IC924	ICOP-00134-SG0	IC DUAL OP AMP	NJM4558M SOP8
IC925	ICOP-00134-SG0	IC DUAL OP AMP	NJM4558M SOP8
IC926	ICOP-00134-SG0	IC DUAL OP AMP	NJM4558M SOP8
IC927	ICOP-00134-SG0	IC DUAL OP AMP	NJM4558M SOP8
IC928	ICOP-00134-SG0	IC DUAL OP AMP	NJM4558M SOP8
IC929	ICOP-00134-SG0	IC DUAL OP AMP	NJM4558M SOP8
IC931	ICOP-00134-SG0	IC DUAL OP AMP	NJM4558M SOP8
IC932	ICOP-00134-SG0	IC DUAL OP AMP	NJM4558M SOP8
IC933	ICOP-00134-SG0	IC DUAL OP AMP	NJM4558M SOP8
IC934	ICOP-00134-SG0	IC DUAL OP AMP	NJM4558M SOP8
IC935	ICOP-00134-SG0	IC DUAL OP AMP	NJM4558M SOP8
IC938	ICOP-00134-SG0	IC DUAL OP AMP	NJM4558M SOP8
IC939	ICOP-00134-SG0	IC DUAL OP AMP	NJM4558M SOP8
IC940	ICOP-00134-SG0	IC DUAL OP AMP	NJM4558M SOP8
IC941	ICOP-00134-SG0	IC DUAL OP AMP	NJM4558M SOP8
IC903	ICRG-01240-SG0	IC LOW VOLTAGE REGU	NJM2391DL1-33 TO-252
IC917	ICRG-01240-SG0	IC LOW VOLTAGE REGU	NJM2391DL1-33 TO-252
IC909	ICTT-00400-S70	IC TTL	74HCU04D(R)
IC914	ICTT-00500-S70	IC TTL	74LVC541 SOP20
IC943	ICTT-00560-S70	IC	74LVC157A
L901	KICK-00060-000	COIL CHOCK	8080P-13-220K
L902	KICK-00060-000	COIL CHOCK	8080P-13-220K
L903	KICK-00060-000	COIL CHOCK	8080P-13-220K
L904	KICK-00060-000	COIL CHOCK	8080P-13-220K
L905	KICK-00060-000	COIL CHOCK	8080P-13-220K
L906	KICK-00060-000	COIL CHOCK	8080P-13-220K
L907	KICK-00060-000	COIL CHOCK	8080P-13-220K
L908	KICK-00060-000	COIL CHOCK	8080P-13-220K
L909	KICK-00060-000	COIL CHOCK	8080P-13-220K
L910	KICK-00060-000	COIL CHOCK	8080P-13-220K
L911	KICK-00060-000	COIL CHOCK	8080P-13-220K
L912	KICK-00060-000	COIL CHOCK	8080P-13-220K
L913	KICK-00060-000	COIL CHOCK	8080P-13-220K
L914	KICK-00060-000	COIL CHOCK	8080P-13-220K
L916	KIFR-00530-000	COIL-SPRING	SPC-534 4.7uH 9A
L915	KI0T-4330K-003	COIL-INDUCTOR	33uH K L5 2.3x3.4 LAL02
CW911	KNCW-00140-8TM	CONNECTOR-WAFER	5267-08A 2.5mm MILK
CW904	KNCW-00240-DT9	CONNECTOR-WAFER	53014-13 2.0mm WHT
CW906	KNCW-00240-FT9	CONNECTOR-WAFER	53014-15 2.0mm WHT
CW907	KNCW-00240-FT9	CONNECTOR-WAFER	53014-15 2.0mm WHT
CW909	KNCW-00240-2T9	CONNECTOR-WAFER	53014-02 2.0mm WHT
CW912	KNCW-00240-4T9	CONNECTOR-WAFER	53014-04 2.0mm WHT
CW905	KNCW-00240-5T9	CONNECTOR-WAFER	53014-05 2.0mm WHT
CW908	KNCW-00240-8T9	CONNECTOR-WAFER	53014-08 2.0mm WHT
CW902	KNCW-00760-IT0	CONNECTOR-WAFER	8370-181 1.25mm TOP 18P
CW903	KNCW-00760-UT0	CONNECTOR-WAFER	8370-301 1.25mm TOP 30P
CW901	KNCW-00970-4T9	CONNECTOR-WAFER	JE202-1T-4P
CW910	KNCW-00990-2T9	CONNECTOR-WAFER	JE202A-1T-02
HB901	KORB-00090-000	CHIP FERRITE BEADS	HB-1T2012-221
HB902	KORB-00090-000	CHIP FERRITE BEADS	HB-1T2012-221
HB903	KORB-00090-000	CHIP FERRITE BEADS	HB-1T2012-221
HB904	KORB-00090-000	CHIP FERRITE BEADS	HB-1T2012-221
HB904	KORB-00100-000	CHIP FERRITE BEADS	HB-1T2012-601

## ELECTRICAL PART LIST

HB905	KORB-00100-000	CHIP FERRITE BEADS	HB-1T2012-601
HB906	KORB-00100-000	CHIP FERRITE BEADS	HB-1T2012-601
HB907	KORB-00100-000	CHIP FERRITE BEADS	HB-1T2012-601
HB908	KORB-00100-000	CHIP FERRITE BEADS	HB-1T2012-601
HB909	KORB-00100-000	CHIP FERRITE BEADS	HB-1T2012-601
HB910	KORB-00100-000	CHIP FERRITE BEADS	HB-1T2012-601
HB911	KORB-00100-000	CHIP FERRITE BEADS	HB-1T2012-601
XT901	KTAL-01370-000	CRYSTAL	24.576MHz
XT902	KTAL-01370-000	CRYSTAL	24.576MHz
XT904	KTAL-01370-000	CRYSTAL	24.576MHz
XT903	KTOS-00190-228	OSCILLATOR	D25B12.2880NTS
	MPAC-17700-004	EMI SPRING	
PCB1	PCWR-06060-1KL	PCB DOUBLE	A1R-606 280x215x1.6t
R1011	RCPB-C000J-23C	RESISTOR-CHIP C/FILM	0ohm 1/16W
R1009	RCPB-C100J-23C	RESISTOR-CHIP C/FILM	10ohm 1/16W 5% B
R1010	RCPB-C100J-23C	RESISTOR-CHIP C/FILM	10ohm 1/16W 5% B
R1087	RCPB-C100J-23C	RESISTOR-CHIP C/FILM	10ohm 1/16W 5% B
R1088	RCPB-C100J-23C	RESISTOR-CHIP C/FILM	10ohm 1/16W 5% B
R1089	RCPB-C100J-23C	RESISTOR-CHIP C/FILM	10ohm 1/16W 5% B
R1090	RCPB-C100J-23C	RESISTOR-CHIP C/FILM	10ohm 1/16W 5% B
R1091	RCPB-C100J-23C	RESISTOR-CHIP C/FILM	10ohm 1/16W 5% B
R1092	RCPB-C100J-23C	RESISTOR-CHIP C/FILM	10ohm 1/16W 5% B
R1093	RCPB-C100J-23C	RESISTOR-CHIP C/FILM	10ohm 1/16W 5% B
R1094	RCPB-C100J-23C	RESISTOR-CHIP C/FILM	10ohm 1/16W 5% B
R1233	RCPB-C100J-23C	RESISTOR-CHIP C/FILM	10ohm 1/16W 5% B
R1234	RCPB-C100J-23C	RESISTOR-CHIP C/FILM	10ohm 1/16W 5% B
R1014	RCPB-C101J-23C	RESISTOR-CHIP C/FILM	100ohm 1/16W 5% B
R1015	RCPB-C101J-23C	RESISTOR-CHIP C/FILM	100ohm 1/16W 5% B
R1016	RCPB-C101J-23C	RESISTOR-CHIP C/FILM	100ohm 1/16W 5% B
R1017	RCPB-C101J-23C	RESISTOR-CHIP C/FILM	100ohm 1/16W 5% B
R1018	RCPB-C101J-23C	RESISTOR-CHIP C/FILM	100ohm 1/16W 5% B
R1028	RCPB-C101J-23C	RESISTOR-CHIP C/FILM	100ohm 1/16W 5% B
R1038	RCPB-C101J-23C	RESISTOR-CHIP C/FILM	100ohm 1/16W 5% B
R1039	RCPB-C101J-23C	RESISTOR-CHIP C/FILM	100ohm 1/16W 5% B
R1040	RCPB-C101J-23C	RESISTOR-CHIP C/FILM	100ohm 1/16W 5% B
R1041	RCPB-C101J-23C	RESISTOR-CHIP C/FILM	100ohm 1/16W 5% B
R1042	RCPB-C101J-23C	RESISTOR-CHIP C/FILM	100ohm 1/16W 5% B
R1043	RCPB-C101J-23C	RESISTOR-CHIP C/FILM	100ohm 1/16W 5% B
R1044	RCPB-C101J-23C	RESISTOR-CHIP C/FILM	100ohm 1/16W 5% B
R1045	RCPB-C101J-23C	RESISTOR-CHIP C/FILM	100ohm 1/16W 5% B
R1046	RCPB-C101J-23C	RESISTOR-CHIP C/FILM	100ohm 1/16W 5% B
R1047	RCPB-C101J-23C	RESISTOR-CHIP C/FILM	100ohm 1/16W 5% B
R1048	RCPB-C101J-23C	RESISTOR-CHIP C/FILM	100ohm 1/16W 5% B
R1052	RCPB-C101J-23C	RESISTOR-CHIP C/FILM	100ohm 1/16W 5% B
R1054	RCPB-C101J-23C	RESISTOR-CHIP C/FILM	100ohm 1/16W 5% B
R1066	RCPB-C101J-23C	RESISTOR-CHIP C/FILM	100ohm 1/16W 5% B
R1067	RCPB-C101J-23C	RESISTOR-CHIP C/FILM	100ohm 1/16W 5% B
R1068	RCPB-C101J-23C	RESISTOR-CHIP C/FILM	100ohm 1/16W 5% B
R1069	RCPB-C101J-23C	RESISTOR-CHIP C/FILM	100ohm 1/16W 5% B
R1070	RCPB-C101J-23C	RESISTOR-CHIP C/FILM	100ohm 1/16W 5% B
R1071	RCPB-C101J-23C	RESISTOR-CHIP C/FILM	100ohm 1/16W 5% B
R1072	RCPB-C101J-23C	RESISTOR-CHIP C/FILM	100ohm 1/16W 5% B
R1076	RCPB-C101J-23C	RESISTOR-CHIP C/FILM	100ohm 1/16W 5% B
R1077	RCPB-C101J-23C	RESISTOR-CHIP C/FILM	100ohm 1/16W 5% B
R1175	RCPB-C101J-23C	RESISTOR-CHIP C/FILM	100ohm 1/16W 5% B
R1176	RCPB-C101J-23C	RESISTOR-CHIP C/FILM	100ohm 1/16W 5% B
R1177	RCPB-C101J-23C	RESISTOR-CHIP C/FILM	100ohm 1/16W 5% B
R1178	RCPB-C101J-23C	RESISTOR-CHIP C/FILM	100ohm 1/16W 5% B
R1179	RCPB-C101J-23C	RESISTOR-CHIP C/FILM	100ohm 1/16W 5% B
R1212	RCPB-C101J-23C	RESISTOR-CHIP C/FILM	100ohm 1/16W 5% B
R1213	RCPB-C101J-23C	RESISTOR-CHIP C/FILM	100ohm 1/16W 5% B
R1236	RCPB-C101J-23C	RESISTOR-CHIP C/FILM	100ohm 1/16W 5% B
R1241	RCPB-C101J-23C	RESISTOR-CHIP C/FILM	100ohm 1/16W 5% B
R1242	RCPB-C101J-23C	RESISTOR-CHIP C/FILM	100ohm 1/16W 5% B
R1243	RCPB-C101J-23C	RESISTOR-CHIP C/FILM	100ohm 1/16W 5% B
R1244	RCPB-C101J-23C	RESISTOR-CHIP C/FILM	100ohm 1/16W 5% B











## ELECTRICAL PART LIST

R938	RCPB-F200J-001	RESISTOR-CHIP C/FILM	20ohm 5% 1/4W 1210
R939	RCPB-F6R2J-0C0	RESISTOR CHIP	6.2ohm 0.25W 1206 5%
R940	RCPB-F6R2J-0C0	RESISTOR CHIP	6.2ohm 0.25W 1206 5%
R941	RCPB-F6R2J-0C0	RESISTOR CHIP	6.2ohm 0.25W 1206 5%
R942	RCPB-F6R2J-0C0	RESISTOR CHIP	6.2ohm 0.25W 1206 5%
R943	RCPB-F6R2J-0C0	RESISTOR CHIP	6.2ohm 0.25W 1206 5%
R944	RCPB-F6R2J-0C0	RESISTOR CHIP	6.2ohm 0.25W 1206 5%
R945	RCPB-F6R2J-0C0	RESISTOR CHIP	6.2ohm 0.25W 1206 5%
R946	RCPB-F6R2J-0C0	RESISTOR CHIP	6.2ohm 0.25W 1206 5%
R947	RCPB-F6R2J-0C0	RESISTOR CHIP	6.2ohm 0.25W 1206 5%
R948	RCPB-F6R2J-0C0	RESISTOR CHIP	6.2ohm 0.25W 1206 5%
R949	RCPB-F6R2J-0C0	RESISTOR CHIP	6.2ohm 0.25W 1206 5%
R950	RCPB-F6R2J-0C0	RESISTOR CHIP	6.2ohm 0.25W 1206 5%
R951	RCPB-F6R2J-0C0	RESISTOR CHIP	6.2ohm 0.25W 1206 5%
R952	RCPB-F6R2J-0C0	RESISTOR CHIP	6.2ohm 0.25W 1206 5%
R953	RCPB-F6R2J-0C0	RESISTOR CHIP	6.2ohm 0.25W 1206 5%
R954	RCPB-F6R2J-0C0	RESISTOR CHIP	6.2ohm 0.25W 1206 5%
R955	RCPB-F6R2J-0C0	RESISTOR CHIP	6.2ohm 0.25W 1206 5%
R956	RCPB-F6R2J-0C0	RESISTOR CHIP	6.2ohm 0.25W 1206 5%
R957	RCPB-F6R2J-0C0	RESISTOR CHIP	6.2ohm 0.25W 1206 5%
R958	RCPB-F6R2J-0C0	RESISTOR CHIP	6.2ohm 0.25W 1206 5%
R959	RCPB-F6R2J-0C0	RESISTOR CHIP	6.2ohm 0.25W 1206 5%
AC901	SKAO-00290-000	AC OUTLET	A204D0043P
SP902	TESP-00531-04P	TERMINAL SPEAKER	SH0410375G
SP901	TESP-00541-08P	TERMINAL SPEAKER	SH0810367G
SP903	TESP-00551-02P	TERMINAL SPEAKER	SH0210384G
PT901	TFMA-00130-000	PLUS-TRANS	KP-250
Q901	TRBC-02130-SD0	TRANSISTOR	KRC107S
Q902	TRBC-02130-SD0	TRANSISTOR	KRC107S
Q903	TRBC-02130-SD0	TRANSISTOR	KRC107S
Q904	TRBC-02130-SD0	TRANSISTOR	KRC107S
Q905	TRTA-0008Y-SD0	TRANSISTOR P-H FREQ	KTA1266-Y T092
Q906	TRTC-01700-SD0	TRANSISTOR N-H FREQ	KRC107M W/RESIST T092M
	UM08-D1074-000	WIRE-ASS'Y	1533/2547#28 GRV-270 13P
	U1T1-01211-Z00	WIRE-ASS'Y	1007#16 BLK 110 3.20RING
	U208-11606-250	WIRE-ASS'Y	1007#24 BRN-60 2P

**DIGITAL INPUT**

LOCNUM	SONITM	MATDES	MATSPC
C403	CCAT-F103Z-AAF	CAPACITOR CERAMIC	0.01uF Z 25V F T
C404	CCAT-F103Z-AAF	CAPACITOR CERAMIC	0.01uF Z 25V F T
C409	CCAT-F103Z-AAF	CAPACITOR CERAMIC	0.01uF Z 25V F T
C405	CCAT-J104Z-AAF	CAPACITOR CERAMIC	0.1uF Z 50V F T
C406	CCAT-J104Z-AAF	CAPACITOR CERAMIC	0.1uF Z 50V F T
C407	CCAT-J104Z-AAF	CAPACITOR CERAMIC	0.1uF Z 50V F T
C408	CCAT-J104Z-AAF	CAPACITOR CERAMIC	0.1uF Z 50V F T
C401	CCAT-J220J-AAZ	CAPACITOR CERAMIC	22PF J 50V SL T
C402	CCAT-J220J-AAZ	CAPACITOR CERAMIC	22PF J 50V SL T
	ICTT-00400-S70	IC TTL	74HCU04D(R)
L401	KI0T-4330K-003	COIL-INDUCTOR	33uH K L5 2.3x3.4 LAL02
L402	KI0T-4330K-003	COIL-INDUCTOR	33uH K L5 2.3x3.4 LAL02
L403	KI0T-4330K-003	COIL-INDUCTOR	33uH K L5 2.3x3.4 LAL02
J7	KNCW-00240-DT9	CONNECTOR-WAFER	53014-13 2.0mm WHT
	PCSR-06120-11B	PCB-SINGLE	A1R-612 247x197x1.6t
R407	RCFT-E101J-000	RESISTOR-CARBON FILM	100ohm 1/5W 5% T
R402	RCFT-E104J-000	RESISTOR-CARBON FILM	100Kohm 1/5W 5% T
R405	RCFT-E104J-000	RESISTOR-CARBON FILM	100Kohm 1/5W 5% T
R409	RCFT-E105J-000	RESISTOR-CARBON FILM	1Mohm 1/5W 5% T
R410	RCFT-E105J-000	RESISTOR-CARBON FILM	1Mohm 1/5W 5% T
R411	RCFT-E182J-000	RESISTOR-CARBON FILM	1.8Kohm 1/5W 5% T
R413	RCFT-E222J-000	RESISTOR-CARBON FILM	2.2Kohm 1/5W 5% T
R414	RCFT-E222J-000	RESISTOR-CARBON FILM	2.2Kohm 1/5W 5% T
R408	RCFT-E301J-000	RESISTOR-CARBON FILM	300ohm 1/5W 5% T
C410	RCFT-E471J-000	RESISTOR-CARBON FILM	470ohm 1/5W 5% T
C411	RCFT-E471J-000	RESISTOR-CARBON FILM	470ohm 1/5W 5% T
R412	RCFT-E473J-000	RESISTOR-CARBON FILM	47Kohm 1/5W 5% T
R415	RCFT-E473J-000	RESISTOR-CARBON FILM	47Kohm 1/5W 5% T
R403	RCFT-E681J-000	RESISTOR-CARBON FILM	680ohm 1/5W 5% T

## ELECTRICAL PART LIST

R406	RCFT-E681J-000	RESISTOR-CARBON FILM	680ohm 1/5W 5% T
R401	RCFT-E750J-000	RESISTOR-CARBON FILM	75ohm 1/5W 5% T
R404	RCFT-E750J-000	RESISTOR-CARBON FILM	75ohm 1/5W 5% T
JW401	RJWT-00000-AA0	RESISTOR-JUMPER WIRE	60mm-TX123 F
JW402	RJWT-00000-AA0	RESISTOR-JUMPER WIRE	60mm-TX123 F
JW403	RJWT-00000-AA0	RESISTOR-JUMPER WIRE	60mm-TX123 F
JW404	RJWT-00000-AA0	RESISTOR-JUMPER WIRE	60mm-TX123 F
JW405	RJWT-00000-AA0	RESISTOR-JUMPER WIRE	60mm-TX123 F
JW406	RJWT-00000-AA0	RESISTOR-JUMPER WIRE	60mm-TX123 F
JW407	RJWT-00000-AA0	RESISTOR-JUMPER WIRE	60mm-TX123 F
JW408	RJWT-00000-AA0	RESISTOR-JUMPER WIRE	60mm-TX123 F
JW409	RJWT-00000-AA0	RESISTOR-JUMPER WIRE	60mm-TX123 F
IC403	SKMJ-00360-000	TRANSMITTING MODULE	VST5A/5B
IC401	SKMJ-00370-000	RECEIVING MODULE	VSR5A/5B
IC402	SKMJ-00370-000	RECEIVING MODULE	VSR5A/5B
JK402	SKRC-00672-01P	SOCKET-RCA	JC010126JG
JK401	SKRC-01262-02P	PIN JACK BOARD	JS020130ZG
PT401	TFMA-00130-000	PLUS-TRANS	KP-250

# μPD78F4216

## • 100-pin plastic QFP (14 × 20)

μPD78F4216AGF-3BA, μPD78F4218AGF-3BA, μPD78F4216AYGF-3BA, μPD78F4218AYGF-3BA

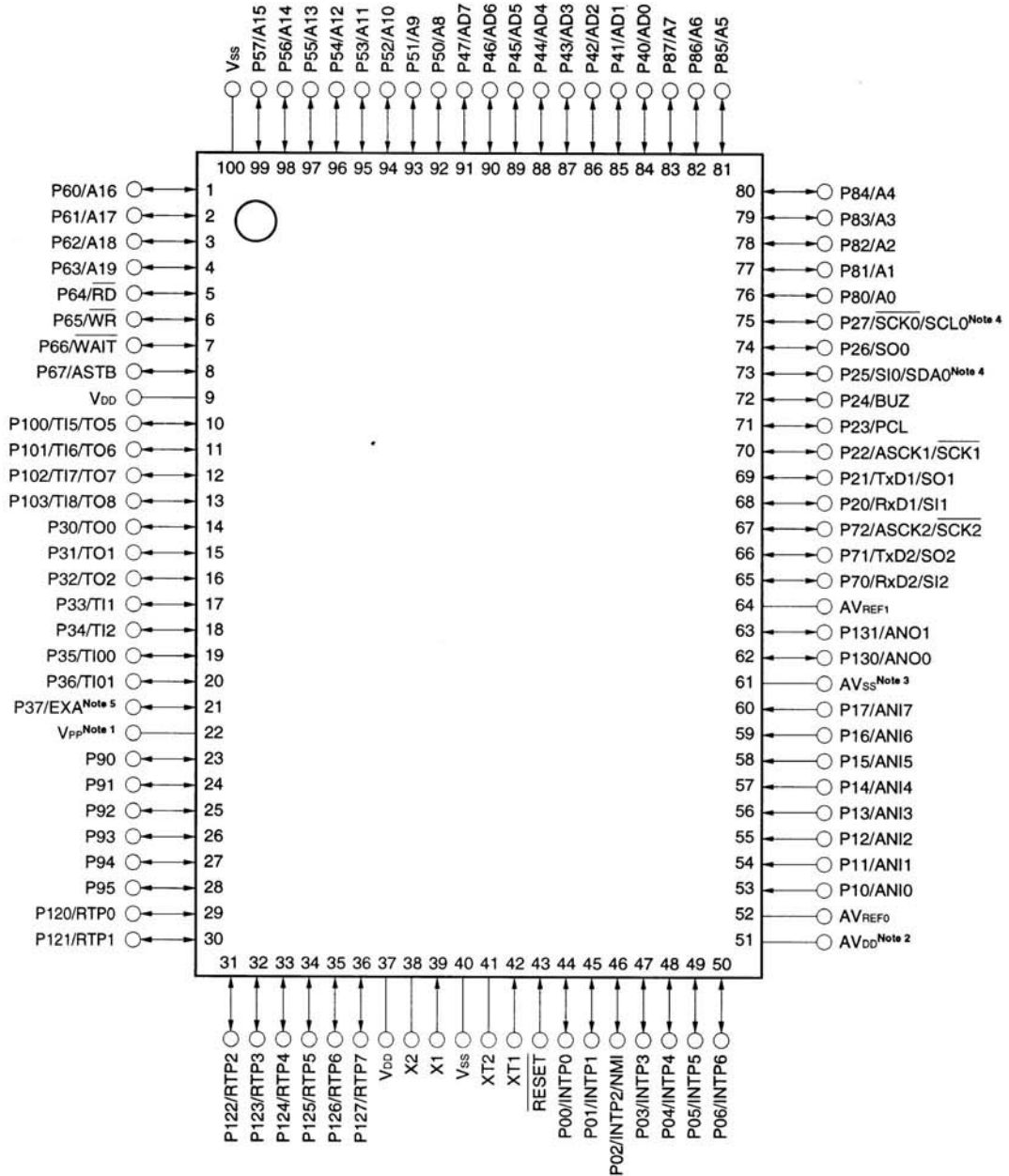

**Notes 1.** Connect the  $V_{PP}$  pin to  $V_{SS}$  directly or via a pull-down resistor in normal operation mode. Connect the  $V_{PP}$  pin to  $V_{SS}$  via a pull-down resistor in a system in which the on-chip flash memory is written while mounted on the target board. For the pull-down connection, it is recommended to use a resistor with a resistance ranging from  $470\ \Omega$  to  $10\ k\Omega$ .

**2.** Connect the  $AV_{DD}$  pin to  $V_{DD}$ .

**3.** Connect the  $AV_{SS}$  pin to  $V_{SS}$ .

**4.** The  $SCL0$  and  $SDA0$  pins are available in the  $\mu PD78F4216AY$ ,  $78F4218AY$  only.

**5.** The  $EXA$  pin is available in the  $\mu PD78F4218A$ ,  $78F4218AY$  only.

## DPR 1001/2002 MICOM PIN DESCRIPTION

Pin	Pin Name	I/O	Mark	Function
1	P60	out	pt_4382_rst	
2	P61	out	pt_4382_cs	
3	P62	out	pt_addr18	
4	P63	out	pt_addr17	
5	P64	out	pt_addr16	
6	P65	out	pt_addr15	
7	P66	out	pt_4114_sclk, pt_4382_sclk	
8	P67	out	pt_4114_sdin, pt_4382_sdin	
9	Vdd			connect Vdd
10	P100	out	pt_49326_cs	
11	P101	in	pt_49326_sdo	
12	P102	out	pt_49326_abt	
13	P103	out	pt_49326_rst	
14	P30	out	pt_pld_mode0	
15	P31	out	pt_pld_rst	
16	P32	out	pt_coax_io	
17	P33	out	pt_4114_rst	
18	P34	in	pt_4114_sdo	
19	P35	out	pt_4114_cs	
20	P36	out	pt_pld_mode1	
21	P37	out	pt_vid4_mute	
22	Vpp			
23	P90	out	pt_4100_dt	
24	P91	out	pt_4100_clk2	
25	P92	out	pt_4100_clk1	
26	P93	out	pt_4100_pd	
27	P94	out	pt_multi_sel	
28	P95	out	pt_4100_rst	
29	P120	out	pt_49326_sclk	
30	P121	out	pt_49326_sdin	
31	P122	out	pt_4382_f_mute	
32	P123	out	pt_4382_c_mute	
33	P124	out	pt_4382_s_mute	
34	P125	out	pt_2100_pd	
35	P126	out	pt_4382_w_mute	
36	P127	out	pt_4382_b_mute	
37	Vdd			
38	X2			
39	X1	in		
40	Vss			GND
41	XT2			
42	XT1	in		GND
43	RESET	in		system reset
44	P00/INTP0	in	pt_rmc	
45	P01/INTP1	in	pt_intreq	

46	P02/INTP2	in	pt_rdsclk	
47	P03/INTP3	in	pt_mlt	
48	P04/INTP4	in	pt_grid_in	
49	P05/INTP5	in	pt_pll_dout	
50	P06/INTP6	out	pt_pll_ce	
51	Avdd			connect Vdd
52	AVref0			connect Vdd
53	P10	in	pt_tu_opt	RDS/FM_O/1001
54	P11	in	pt_key_b	
55	P12	in	pt_key_a	
56	P13	in	pt_hp_out	
57	P14	in	pt_pwr_dn	
58	P15	in	pt_rds_data	
59	P16	in	pt_stereo	
60	P17	in	pt_tuned	
61	Avss			GND
62	P130	out	pt_24c_clk	
63	P131	out	pt_24c_data	
64	Avref1			
65	P70	in		SI2
66	P71	out		SO2
67	P72	out		SCK2
68	P20	out	pt_pll_clk, pt_v_4094_clk	
69	P21	out	pt_pll_dt, pt_v_4094_dt	
70	P22	out	pt_v_4094_ce	
71	P23	in	pt_v_sync	
72	P24	out		not used
73	P25	out	pt_hp_mute	
74	P26	out	pt_mlt_mute	
75	P27	out	pt_rec_mute	
76	P80	out	pt_35017_ce	
77	P81	out	pt_35017_clk	
78	P82	out	pt_9273_ce2	
79	P83	out	pt_9273_ce1	
80	P84	out	pt_9459_clk, pt_78213_clk, pt_9273_clk	
81	P85	out	pt_9459_dt, pt_78223_dt, pt_9273_dt	
82	P86	out	pt_9459_cs	
83	P87	out	pt_78213_ce	
84	P40	out	pt_tnr_mute	
85	P41	out	pt_pwr_rly	
86	P42	out	pt_75725_ce1	
87	P43	out	pt_75725_ce2	
88	P44	out	pt_75725_clk, pt_l_4094_clk	

89	P45	out	pt_75725_dt, pt_l_4094_dt	
90	P46	out	pt_blk_1	
91	P47	out	pt_blk_2	
92	P50	in	pt_enc_b	
93	P51	in	pt_enc_a	
94	P52	out	pt_l_4094_ce	
95	P53	out		not used
96	P54	out		not used
97	P55	out	pt_pwr_led	
98	P56	out	pt_front_5v	
99	P57	out	pt_35017_dt	
100	AVss			GND

# IC DATA SHEET

## CM2052G: Anode & Grid Assignment

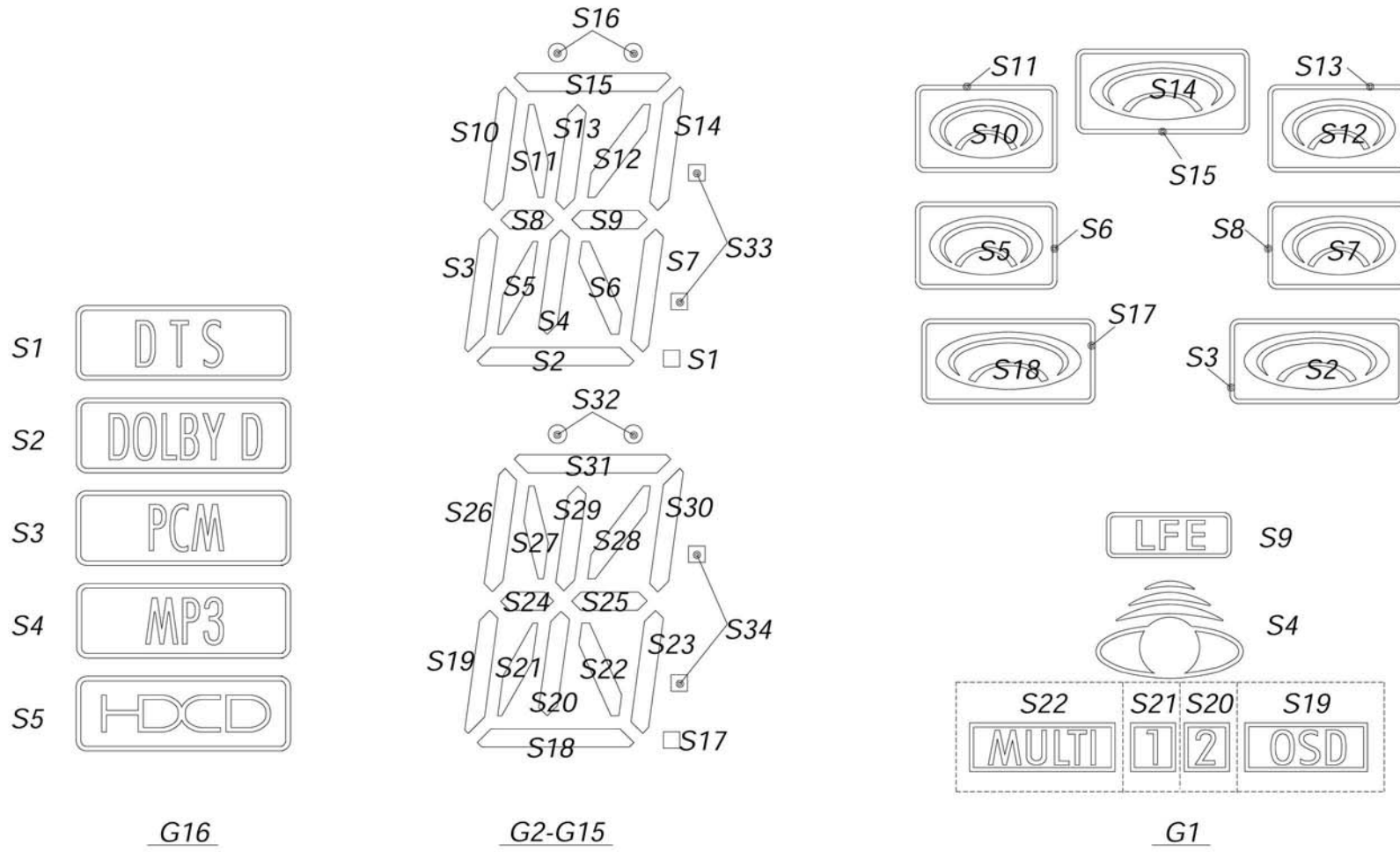
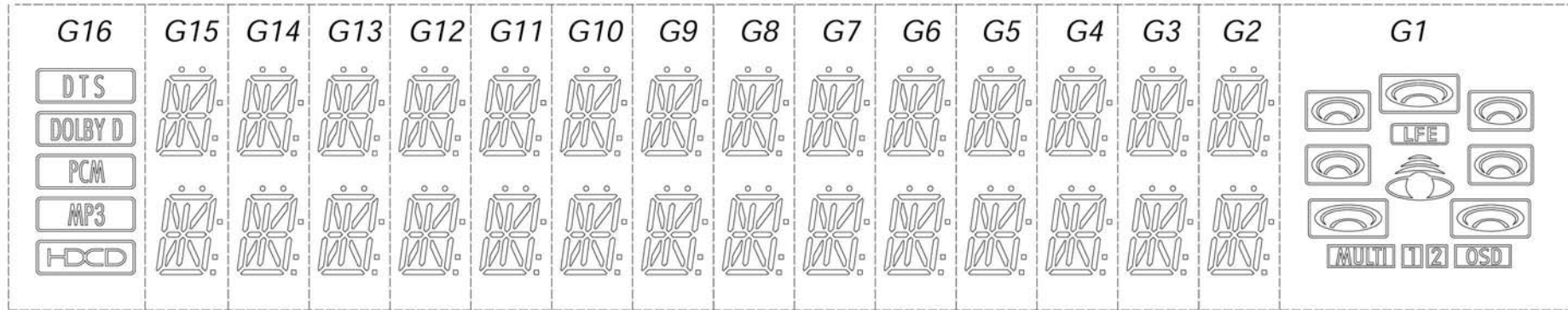

CM2052G:Anode & Grid Assignment

	G1	G2-G15	G16
S1	/	S1	S1
S2	S2	S2	S2
S3	S3	S3	S3
S4	S4	S4	S4
S5	S5	S5	S5
S6	S6	S6	/
S7	S7	S7	/
S8	S8	S8	/
S9	S9	S9	/
S10	S10	S10	/
S11	S11	S11	/
S12	S12	S12	/
S13	S13	S13	/

	G1	G2-G15	G16
S14	S14	S14	/
S15	S15	S15	/
S16	/	S16	/
S17	S17	S17	/
S18	S18	S18	/
S19	S19	S19	/
S20	S20	S20	/
S21	S21	S21	/
S22	S22	S22	/
S23	/	S23	/
S24	/	S24	/
S25	/	S25	/
S26	/	S26	/

	G1	G2-G15	G16
S27	/	S27	/
S28	/	S28	/
S29	/	S29	/
S30	/	S30	/
S31	/	S31	/
S32	/	S32	/
S33	/	S33	/
S34	/	S34	/

PIN ASSIGNMENT

Pin No.	1	2	3	4	5	6	7	8	9	10	11	12	13	14	15	16	17	18	19	20	21	22
Assignment	F1	NL (F1)	F1	NP	NL	S1	S2	S3	S4	S5	S6	S7	S8	S9	S10	S11	S12	S13	S14	S15	S16	G16

Pin No.	23	24	25	26	27	28	29	30	31	32	33	34	35	36	37	38	39	40	41	42	43	44
Assignment	G15	G14	G13	G12	G11	G10	G9	S17	S18	S19	S20	S21	S22	S23	S24	S25	S26	NL	NL	S27	S28	S29

Pin No.	45	46	47	48	49	50	51	52	53	54	55	56	57	58	59	60	61	62	63	64
Assignment	S30	S31	S32	S33	S34	NL	NL	G8	G7	G6	G5	G4	G3	G2	G1	NL	NP	F2	NL (F2)	F2

F1,F2:Filament G1-G16:Grid

S1-S34:Anode NP:No Pin NL:No Lead



## IC DATA SHEET

## LC75725E

## Overview

The LC75725E is a 1/4 to 1/11 duty dynamic drive VFD driver. It provides 43 segment outputs and 11 digit outputs. It facilitates the construction of display systems operating under the control of a controller.

## Features

- Dynamic drive display technique to display four to eleven digits on the VFD.
- Serial data input supports CCB\* format communication with the system controller.
- The dimmer level is controlled by serial data input. (The dimmer has a resolution of 10 bits.)
- High generality since display data is displayed without the intervention of a decoder.
- All segments can be turned off with the  $\overline{\text{BLK}}$  pin.
- CR oscillator circuit.

- CCB is a trademark of SANYO ELECTRIC CO., LTD.
- CCB is SANYO's original bus format and all the bus addresses are controlled by SANYO.

## Package Dimensions

unit: mm

3159-QFP64E

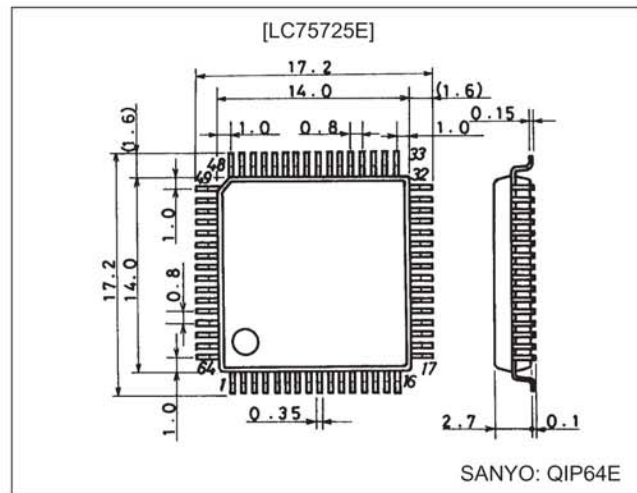

## Specifications

Absolute Maximum Ratings at  $T_a = 25^\circ\text{C}$ ,  $V_{SS} = 0\text{ V}$ 

Parameter	Symbol	Conditions	Ratings	Unit
Maximum supply voltage	$V_{DD\text{ max}}$	$V_{DD}$	-0.3 to +6.5	V
	$V_{FL\text{ max}}$	$V_{FL}$	$V_{DD} - 47$ to $V_{DD} + 0.3$	
Input voltage	$V_{IN1}$	DI, CL, CE, $\overline{\text{BLK}}$	-0.3 to +6.5	V
	$V_{IN2}$	OSCI	-0.3 to $V_{DD} + 0.3$	
Output voltage	$V_{OUT1}$	S1 to S43, G1 to G11	$V_{DD} - 47$ to $V_{DD} + 0.3$	V
	$V_{OUT2}$	OSCO	-0.3 to $V_{DD} + 0.3$	
Output current	$I_{OUT1}$	S1 to S43	10	mA
	$I_{OUT2}$	G1 to G11	30	
Allowable power dissipation	$P_{d\text{ max}}$	$T_a = 85^\circ\text{C}$	300	mW
Operating temperature	$T_{opr}$		-40 to +85	$^\circ\text{C}$
Storage temperature	$T_{stg}$		-50 to +150	$^\circ\text{C}$

## LC75725E

Allowable Operating Ranges at  $T_a = -40$  to  $+85^\circ\text{C}$ ,  $V_{DD} = 4.5$  to  $5.5$  V,  $V_{SS} = 0$  V

Parameter	Symbol	Conditions	Ratings			Unit
			min	typ	max	
Supply voltage	$V_{DD}$	$V_{DD}$	4.5	5.0	5.5	V
	$V_{FL}$	$V_{FL}$	$V_{DD} - 45$		$V_{DD}$	
Input high-level voltage	$V_{IH1}$	DI, CL, CE, $\overline{\text{BLK}}$	$0.8 V_{DD}$		5.5	V
	$V_{IH2}$	OSCI	$0.8 V_{DD}$		$V_{DD}$	
Input low-level voltage	$V_{IL}$	DI, CL, CE, $\overline{\text{BLK}}$ , OSCI	0		$0.2 V_{DD}$	V
Guaranteed oscillator range	$f_{OSC}$	OSCI, OSCO	1.8	3.7	4.9	MHz
Recommended external resistance	$R_{OSC}$	OSCI, OSCO	1.0	5.6	22	$k\Omega$
Recommended external capacitance	$C_{OSC}$	OSCI, OSCO	10	22	47	pF
Low level clock pulse width	$t_{\theta L}$	CL	Figure 1			$\mu\text{s}$
High level clock pulse width	$t_{\theta H}$	CL	Figure 1			$\mu\text{s}$
Data setup time	$t_{ds}$	DI, CL	Figure 1			$\mu\text{s}$
Data hold time	$t_{dh}$	DI, CL	Figure 1			$\mu\text{s}$
CE wait time	$t_{cp}$	CE, CL	Figure 1			$\mu\text{s}$
CE setup time	$t_{cs}$	CE, CL	Figure 1			$\mu\text{s}$
CE hold time	$t_{ch}$	CE, CL	Figure 1			$\mu\text{s}$
$\overline{\text{BLK}}$ switching time	$t_c$	$\overline{\text{BLK}}$ , CE	Figure 3	10		$\mu\text{s}$

## Electrical Characteristics in the Allowable Operating Ranges

Parameter	Symbol	Conditions	Ratings			Unit
			min	typ	max	
Input high-level current	$I_{IH1}$	DI, CL, CE, $\overline{\text{BLK}}$ : $V_I = 5.5$ V			5	$\mu\text{A}$
	$I_{IH2}$	OSCI: $V_I = V_{DD}$		5		
Input low-level current	$I_{IL}$	DI, CL, CE, $\overline{\text{BLK}}$ : $V_I = 0$ V	-5			$\mu\text{A}$
Output high-level voltage	$V_{OH1}$	S1 to S43: $I_O = 5$ mA	$V_{DD} - 2.0$			V
	$V_{OH2}$	G1 to G11: $I_O = 20$ mA	$V_{DD} - 2.0$			
	$V_{OH3}$	OSCO: $I_O = 0.5$ mA	$V_{DD} - 2.0$			
Output low-level voltage	$V_{OL}$	OSCO: $I_O = -0.5$ mA			2.0	V
Output off voltage	$V_{OFF}$	S1 to S43, G1 to G11: $V_{FL} = V_{DD} - 45$ V, Outputs off			$V_{DD} - 44$	V
Pull-down resistors	$R_{PD}$	S1 to S43, G1 to G11: $V_{FL} = V_{DD} - 45$ V, $V_O = V_{DD}$	50	100	200	$k\Omega$
Oscillator frequency	$f_{OSC}$	OSCI, OSCO: $R_{OSC} = 5.6$ $k\Omega$ , $C_{OSC} = 22$ pF		3.7		MHz
Hysteresis voltage	$V_H$	DI, CL, CE, $\overline{\text{BLK}}$		$0.1 V_{DD}$		V
Current drain	$I_{DD}$	$V_{DD}$ : Outputs open. Display off, $f_{OSC} = 3.7$ MHz, $V_{FL} = V_{DD} - 45$ V			5	mA

LC75725E

1. When CL is stopped at the low level

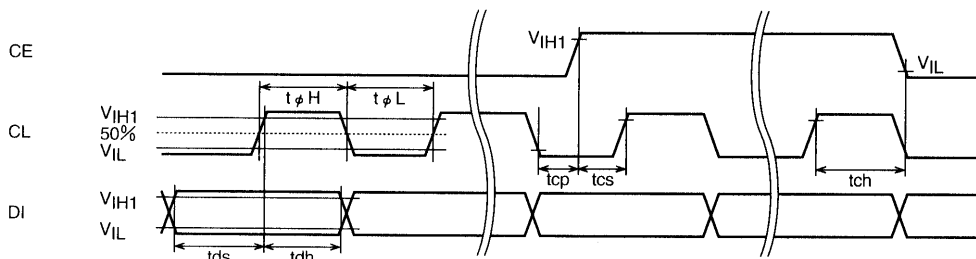

A06733

2. When CL is stopped at the high level

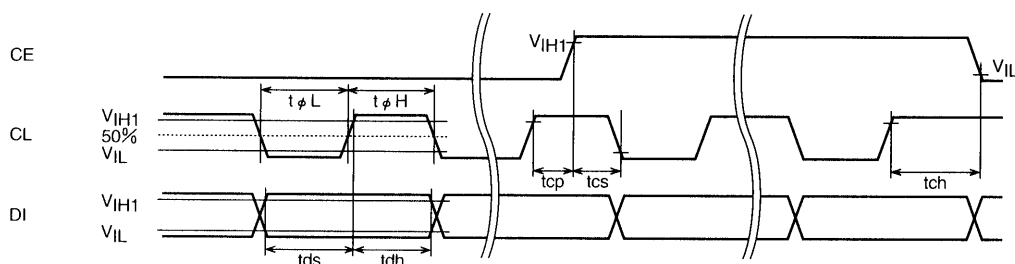

A06734

Figure 1

Pin Assignment

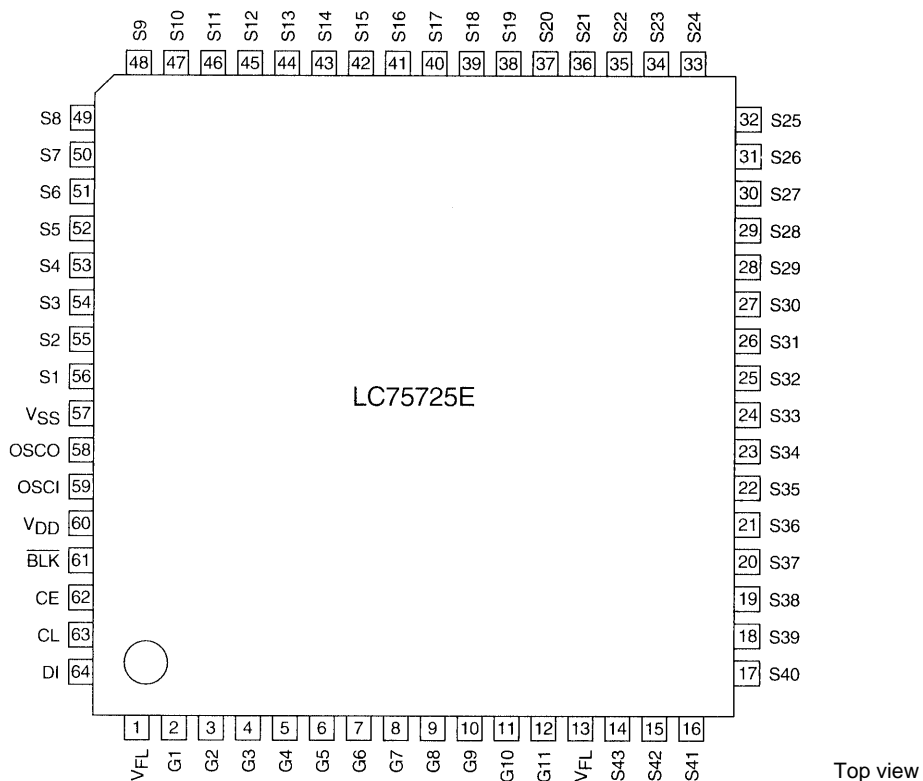

Top view

A06732

LC75725E

Block Diagram

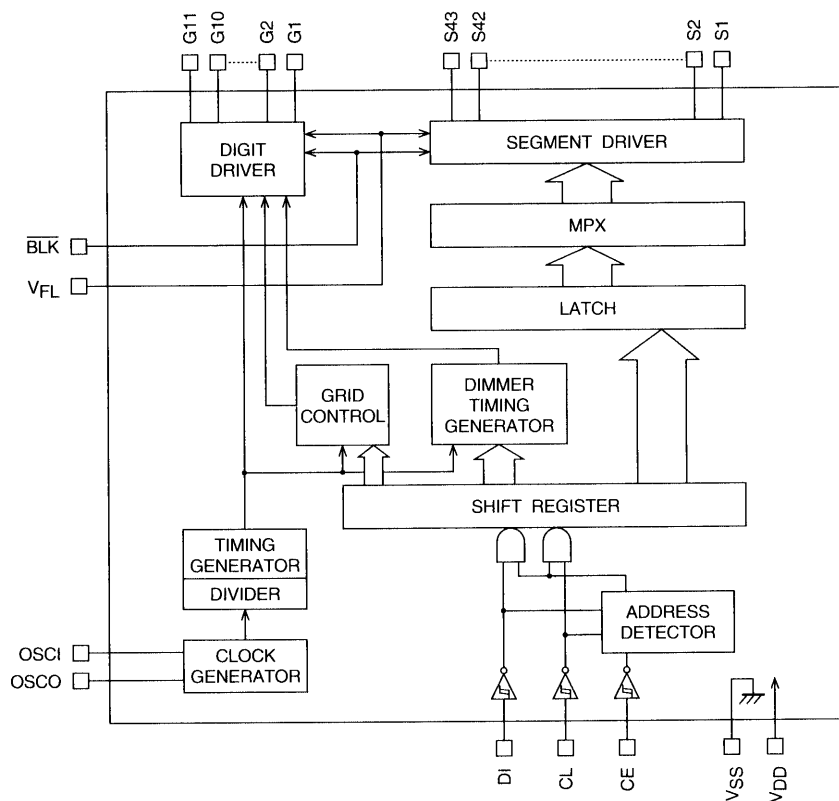

A06735

Pin Functions

Pin	Pin No.	Function	I/O	Handling when unused
V <sub>FL</sub>	1, 13	Driver block power supply connection. (Both pins must be connected.)	—	—
V <sub>DD</sub>	60	Logic block power supply connection. Provide a voltage between 4.5 and 5.5 V.	—	—
V <sub>SS</sub>	57	Power supply connection. Connect to the ground.	—	—
OSC1	59	Oscillator connection. An oscillator circuit is formed by connecting an external resistor and capacitor to these pins.	I	GND
OSCO	58		O	OPEN
$\overline{\text{BLK}}$	61	Display off control input. BLK = Low (V <sub>SS</sub> ) ... Display off. (S1 to S43 and G1 to G11 at V <sub>FL</sub> level.) BLK = High (V <sub>DD</sub> ) ... Display on. Note that serial data can be transferred while the display is turned off.	I	GND
CL	63	Serial data transfer inputs. These pins must be connected to the system microcontroller. CL: Synchronization clock DI: Transfer data CE: Chip enable	I	GND
DI	64			
CE	62			
G1 to G11	2 to 12	Digit outputs. These pins are P-channel open drain outputs with pull-down resistors.	O	OPEN
S1 to S43	56 to 14	Segment outputs for displaying the display data transferred by serial data input. These pins are P-channel open drain outputs with pull-down resistors.	O	OPEN

## CS49326

## Multi-Standard Audio Decoder Family

### Features

- CS4930X: DVD Audio Sub-family
  - PES layer decode for A/V sync
  - DVD Audio Pack Layer Support
  - Meridian Lossless Packing (MLP)<sup>™</sup>
  - Dolby Digital<sup>™</sup>
  - MPEG Multi-Channel
  - DTS Digital Surround<sup>™</sup>
- CS4931X: Broadcast Sub-family
  - PES layer decode for A/V sync
  - MPEG Advanced Audio Coding Algorithm (AAC)
  - MPEG Multi Channel
  - Dolby Digital
- CS4932X: AVR Sub-family
  - Dolby Digital with integrated code
  - DTS decoding with integrated DTS tables & code
  - Crystal Original Surround with integrated code
  - MPEG Advanced Audio Coding Algorithm (AAC)
  - MPEG Multi-Channel
- CS4933X: General Purpose Audio DSP
  - THX<sup>™</sup> and THX Surround EX
  - Car Audio
  - Mixer Applications
- Features are a super-set of the CS4923/4/5/6/7/8
  - 8 channel output, including dual zone output capability
  - Supports up to 192 kHz Fs @ 24 bit throughput
  - Increased memory/MIPs
  - SRAM Interface for increased delay and buffer capability
  - MPEG Layer 3 (MP3)

### Description

The CS493XX is a family of multichannel audio decoders intended to supersede the CS4923/4/5/6/7/8 family as the leader of audio decoding in both the DVD, broadcast and receiver markets. The family will be split into parts tailored for each of these distinct market segments.

For the DVD market, parts will be offered which support Meridian Lossless Packing (MLP), Dolby Digital, MPEG Multi-Channel, DTS and subsets thereof. For the receiver market, parts will be offered which support Dolby Digital, MPEG Multi-Channel, DTS, AAC and subsets thereof. For the broadcast market parts will be offered which support Dolby Digital, MPEG Advanced Audio Coding (AAC), and MPEG Multi-Channel.

Under the Crystal brand, Cirrus Logic is the only single supplier of high-performance 24-bit multi-standard audio DSP decoders, DSP firmware, and high-resolution data converters. This combination of DSPs, system firmware, and data converters simplify rapid creation of world-class high-fidelity products.

**Ordering Information:** See page 68

	APPLICATION	FEATURES
CS49300	DVD Audio	MLP, AC3, DTS and MPEG5.1
CS49310	Broadcast	AAC, AC3, MPEG5.1
CS49325	AVR	AC3(IBA), MPEG5.1
CS49326	AVR	AC3(IBA), DTS(IBA), MPEG5.1
CS49329	AVR	AC3(IBA), AAC, DTS, MPEG5.1, PCM Pass-through (IBA)
CS49330	Audio DSP	THX

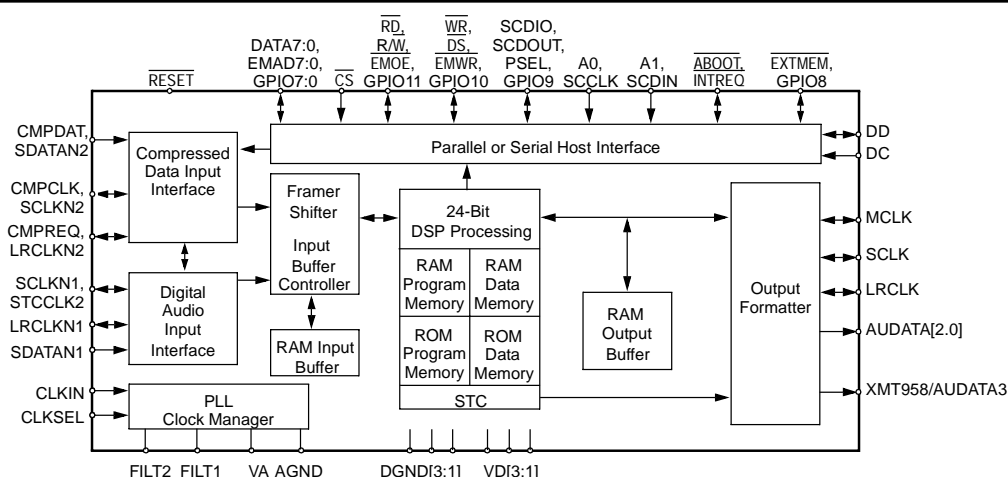

### Preliminary Product Information

This document contains information for a new product. Cirrus Logic reserves the right to modify this product without notice.

## 11. PIN DESCRIPTIONS

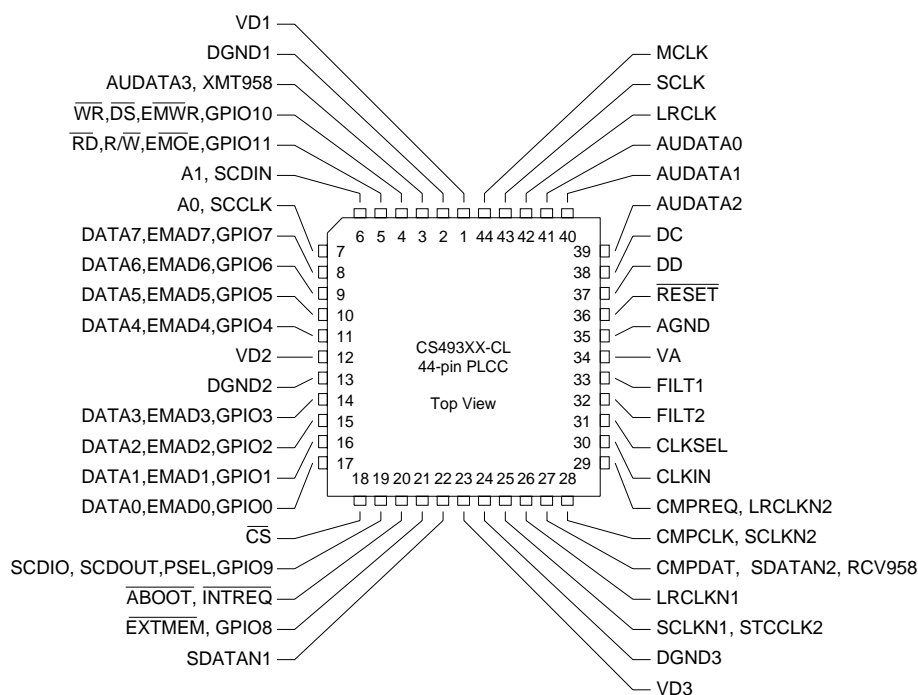

### VA—Analog Positive Supply: Pin 34

Analog positive supply for clock generator. Nominally +2.5 V.

### AGND—Analog Supply Ground: Pin 35

Analog ground for clock generator PLL.

### VD1, VD2, VD3—Digital Positive Supply: Pins 1, 12, 23

Digital positive supplies. Nominally +2.5 V.

### DGND1, DGND2, DGND3—Digital Supply Ground: Pins 2, 13, 24

Digital ground.

### FILT1—Phase-Locked Loop Filter: Pin 33

Connects to an external filter for the on-chip phase-locked loop.

### FILT2—Phase Locked Loop Filter: Pin 32

Connects to an external filter for the on-chip phase-locked loop.

### CLKIN—Master Clock Input: Pin 30

CS493XX clock input. When in internal clock mode ( $CLKSEL = DGND$ ), this input is connected to the internal PLL from which all internal clocks are derived. When in external clock mode ( $CLKSEL = VD$ ), this input is connected to the DSP clock. *INPUT*

**CLKSEL—DSP Clock Select: Pin 31**

This pin selects the clock mode of the CS493XX. When CLKSEL is low, CLKIN is connected to the internal PLL from which all internal clocks are derived. When CLKSEL is high CLKIN is connected to the DSP clock. *INPUT*

**DATA7, EMAD7, GPIO7—Pin 8****DATA6, EMAD6, GPIO6—Pin 9****DATA5, EMAD5, GPIO5—Pin 10****DATA4, EMAD4, GPIO4—Pin 11****DATA3, EMAD3, GPIO3—Pin 14****DATA2, EMAD2, GPIO2—Pin 15****DATA1, EMAD1, GPIO1—Pin 16****DATA0, EMAD0, GPIO0—Pin 17**

In parallel host mode, these pins provide a bidirectional data bus. If a serial host mode is selected, these pins can provide a multiplexed address and data bus for connecting an 8-bit external memory. Otherwise, in serial host mode, these pins can act as general-purpose input or output pins that can be individually configured and controlled by the DSP.

*BIDIRECTIONAL - Default: INPUT*

**A0, SCCLK—Host Parallel Address Bit Zero or Serial Control Port Clock: Pin 7**

In parallel host mode, this pin serves as one of two address input pins used to select one of four parallel registers. In serial host mode, this pin serves as the serial control clock signal, specifically as the SPI clock input or the I<sup>2</sup>C clock input. *INPUT*

**A1, SCDIN—Host Address Bit One or SPI Serial Control Data Input: Pin 6**

In parallel host mode, this pin serves as one of two address input pins used to select one of four parallel registers. In SPI serial host mode, this pin serves as the data input. *INPUT*

 **$\overline{\text{RD}}$ ,  $\overline{\text{R/W}}$ ,  $\overline{\text{EMOE}}$ , GPIO11—Host Parallel Output Enable or Host Parallel  $\overline{\text{R/W}}$  or External Memory Output Enable or General Purpose Input & Output Number 11: Pin 5**

In Intel parallel host mode, this pin serves as the active-low data bus enable input. In Motorola parallel host mode, this pin serves as the read-high/write-low control input signal. In serial host mode, this pin can serve as the external memory active-low data-enable output signal. Also in serial host mode, this pin can serve as a general purpose input or output bit.

*BIDIRECTIONAL - Default: INPUT*

 **$\overline{\text{WR}}$ ,  $\overline{\text{DS}}$ ,  $\overline{\text{EMWR}}$**

**CMPCLK, SCLKN2—PCM Audio Input Bit Clock: Pin 28**

Bidirectional digital-audio bit clock that is an output in master mode and an input in slave mode. In slave mode, SCLKN2 operates asynchronously from all other CS493XX clocks. In master mode, SCLKN2 is derived from the CS493XX internal clock generator. In either master or slave mode, the active edge of SCLKN2 can be programmed by the DSP. If the CDI is configured for bursty delivery, CMPCLK is an input used to sample CMPDAT. *BIDIRECTIONAL - Default: INPUT*

**CMPREQ, LRCLKN2—PCM Audio Input Sample Rate Clock: Pin 29**

When the CDI is configured as a digital audio input, this pin serves as a bidirectional digital-audio frame clock that is an output in master mode and an input in slave mode. LRCLKN2 typically is run at the sampling frequency. In slave mode, LRCLKN2 operates asynchronously from all other CS493XX clocks. In master mode, LRCLKN2 is derived from the CS493XX internal clock generator. In either master or slave mode, the polarity of LRCLKN2 for a particular subframe can be programmed by the DSP. When the CDI is configured for bursty delivery, or parallel audio data delivery is being used, CMPREQ is an output which serves as an internal FIFO monitor. CMPREQ is an active low signal that indicates when another block of data can be accepted. *BIDIRECTIONAL - Default: INPUT*

**CMPDAT, SDATAN2—PCM Audio Data Input Number Two: Pin 27**

Digital-audio data input that can accept from one to six channels of compressed or PCM data. SDATAN2 can be sampled with either edge of SCLKN2, depending on how SCLKN2 has been configured. Similarly CMPDAT is the compressed data input pin when the CDI is configured for bursty delivery. When in this mode, the CS493XX internal PLL is driven by the clock recovered from the incoming data stream. *INPUT*

**DC—Reserved: Pin 38**

This pin is reserved and should be pulled up with an external 4.7k resistor.

**DD—Reserved: Pin 37**

This pin is reserved and should be pulled up with an external 4.7k resistor.

**12. ORDERING INFORMATION**

CS493002-CL 44-Pin PLCC	Temp Range 0-70° C
CS493102-CL 44-Pin PLCC	Temp Range 0-70° C
CS493253-CL 44-Pin PLCC	Temp Range 0-70° C
CS493263-CL 44-Pin PLCC	Temp Range 0-70° C
CS493292-CL 44-Pin PLCC	Temp Range 0-70° C



**MCLK—Audio Master Clock: Pin 44**

Bidirectional master audio clock. MCLK can be an output from the CS493XX that provides an oversampled audio-output clock at either 128 Fs, 256 Fs, or 512 Fs. MCLK can be an input at 128 Fs, 256 Fs, 384 Fs, or 512 Fs. MCLK is used to derive SCLK and LRCLK when SCLK and LRCLK are driven by the CS493XX. *BIDIRECTIONAL - Default: INPUT*

**SCLK—Audio Output Bit Clock: Pin 43**

Bidirectional digital-audio output bit clock. SCLK can be an output that is derived from MCLK to provide 32 Fs, 64 Fs, 128 Fs, 256 Fs, or 512 Fs, depending on the MCLK rate and the digital-output configuration. SCLK can also be an input and must be at least 48Fs or greater. As an input, SCLK is independent of MCLK. *BIDIRECTIONAL - Default: INPUT*

**LRCLK—Audio Output Sample Rate Clock: Pin 42**

Bidirectional digital-audio output-sample-rate clock. LRCLK can be an output that is divided from MCLK to provide the output sample rate depending on the output configuration. LRCLK can also be an input. As an input LRCLK is independent of MCLK. *BIDIRECTIONAL - Default: INPUT*

**AUDATA3,XMT958—SPDIF Transmitter Output, Digital Audio Output 3: Pin 3**

CMOS level output that contains a biphase-encoded clock for synchronously providing two channels of PCM digital audio or a IEC61937 compressed-data interface or both. This output typically connects to the input of an RS-422 transmitter or to the input of an optical transmitter. Conversely this pin can be configured to be a third digital audio output. *OUTPUT*

**SCLKN1, STCCLK2—PCM Audio Input Bit Clock: Pin 25**

Bidirectional digital-audio bit clock that is an output in master mode and an input in slave mode. In slave mode, SCLKN1 operates asynchronously from all other CS493XX clocks. In master mode, SCLKN1 is derived from the CS493XX internal clock generator. In either master or slave mode, the active edge of SCLKN1 can be programmed by the DSP. For applications supporting PES layer synchronization this pin can be used as STCCLK2, which provides a path to the internal STC 33 bit counter. *BIDIRECTIONAL - Default: INPUT*

**LRCLKN1—PCM Audio Input Sample Rate Clock: Pin 26**

Bidirectional digital-audio frame clock that is an output in master mode and an input in slave mode. LRCLKN1 typically is run at the sampling frequency. In slave mode, LRCLKN1 operates asynchronously from all other CS493XX clocks. In master mode, LRCLKN1 is derived from the CS493XX internal clock generator. In either master or slave mode, the polarity of LRCLKN1 for a particular subframe can be programmed by the DSP. *BIDIRECTIONAL - Default: INPUT*

**SDATAN1—PCM Audio Data Input Number One: Pin 22**

Digital-audio data input that can accept from one to six channels of compressed or PCM data. SDATAN1 can be sampled with either edge of SCLKN1, depending on how SCLKN1 has been configured. *INPUT*

**CMPCLK, SCLKN2—PCM Audio Input Bit Clock: Pin 28**

Bidirectional digital-audio bit clock that is an output in master mode and an input in slave mode. In slave mode, SCLKN2 operates asynchronously from all other CS493XX clocks. In master mode, SCLKN2 is derived from the CS493XX internal clock generator. In either master or slave mode, the active edge of SCLKN2 can be programmed by the DSP. If the CDI is configured for bursty delivery, CMPCLK is an input used to sample CMPDAT. *BIDIRECTIONAL - Default: INPUT*

**CMPREQ, LRCLKN2—PCM Audio Input Sample Rate Clock: Pin 29**

When the CDI is configured as a digital audio input, this pin serves as a bidirectional digital-audio frame clock that is an output in master mode and an input in slave mode. LRCLKN2 typically is run at the sampling frequency. In slave mode, LRCLKN2 operates asynchronously from all other CS493XX clocks. In master mode, LRCLKN2 is derived from the CS493XX internal clock generator. In either master or slave mode, the polarity of LRCLKN2 for a particular subframe can be programmed by the DSP. When the CDI is configured for bursty delivery, or parallel audio data delivery is being used, CMPREQ is an output which serves as an internal FIFO monitor. CMPREQ is an active low signal that indicates when another block of data can be accepted. *BIDIRECTIONAL - Default: INPUT*

**CMPDAT, SDATAN2—PCM Audio Data Input Number Two: Pin 27**

Digital-audio data input that can accept from one to six channels of compressed or PCM data. SDATAN2 can be sampled with either edge of SCLKN2, depending on how SCLKN2 has been configured. Similarly CMPDAT is the compressed data input pin when the CDI is configured for bursty delivery. When in this mode, the CS493XX internal PLL is driven by the clock recovered from the incoming data stream. *INPUT*

**DC—Reserved: Pin 38**

This pin is reserved and should be pulled up with an external 4.7k resistor.

**DD—Reserved: Pin 37**

This pin is reserved and should be pulled up with an external 4.7k resistor.

**12. ORDERING INFORMATION**

CS493002-CL	44-Pin PLCC	Temp Range 0-70° C
CS493102-CL	44-Pin PLCC	Temp Range 0-70° C
CS493253-CL	44-Pin PLCC	Temp Range 0-70° C
CS493263-CL	44-Pin PLCC	Temp Range 0-70° C
CS493292-CL	44-Pin PLCC	Temp Range 0-70° C

# DDX-4100A

## DDX™ Multichannel Digital Audio Processor

### FEATURES

- SOURCE-TO-SPEAKER INTEGRATED DIGITAL AUDIO SOLUTION w/DDX-2060 Power IC's
- DIGITAL PREAMP FUNCTIONS:
  - Digital Volume Control
  - Bass and Treble
  - Parametric EQ on each Channel
  - Bass Management for LFE Channel
  - Soft Mute
  - Automatic mute for Zero Inputs
- 4+1 CHANNELS DDX PROCESSING
- STEREO S/PDIF INPUT INTERFACE
- 4 CHANNEL PROGRAMMABLE SERIAL INPUT INTERFACE
- 6 CHANNEL PROGRAMMABLE SERIAL OUTPUT INTERFACE
- Intel AC'97 LINK (rev.2.1) INPUT INTERFACE for AUDIO AND CONTROL
- AUTOMATIC INPUT SAMPLING FREQUENCY DETECTION AND SAMPLE RATE CONVERTER
- I<sup>2</sup>C CONTROL BUS
- LOW POWER 3.3V CMOS TECHNOLOGY
- EXTERNAL INPUT CLOCK OR BUILT-IN XTAL OSCILLATOR
- DIGITAL GAIN CONTROL; UP TO +24dB @ 0.75dB/STEP

### 1.0 GENERAL DESCRIPTION

The DDX-4100A Digital Audio Processor is a single chip device for implementing complete digital solutions for audio amplification. In conjunction with multiple DDX-2060 Power IC's, the solution provides a full digital, multi-channel, high quality, power processing chain without the need of Digital-to-Analog converters between the DSP and power amplifier.

The device supports two input configurations, AC'97 input mode or IIS/SPDIF input mode, with the selection made via a dedicated pin (*AC97\_MODE pin*).

The AC'97 input mode can be configured to work in either a 'Fully Compliant' mode or a 'Proprietary' mode. The selection of this compliance mode is made in a Vendor Reserved register. The 'Fully Compliant' mode conforms to rev 2.1 of AC'97 specification. The 'Proprietary' mode enables additional features not found in the 'Fully Compliant' mode. The link supports up to 6 input channels with discrete sampling frequencies of 44.1, 48, 88.2, or 96 kHz.

### DDX-4100A BLOCK DIAGRAM

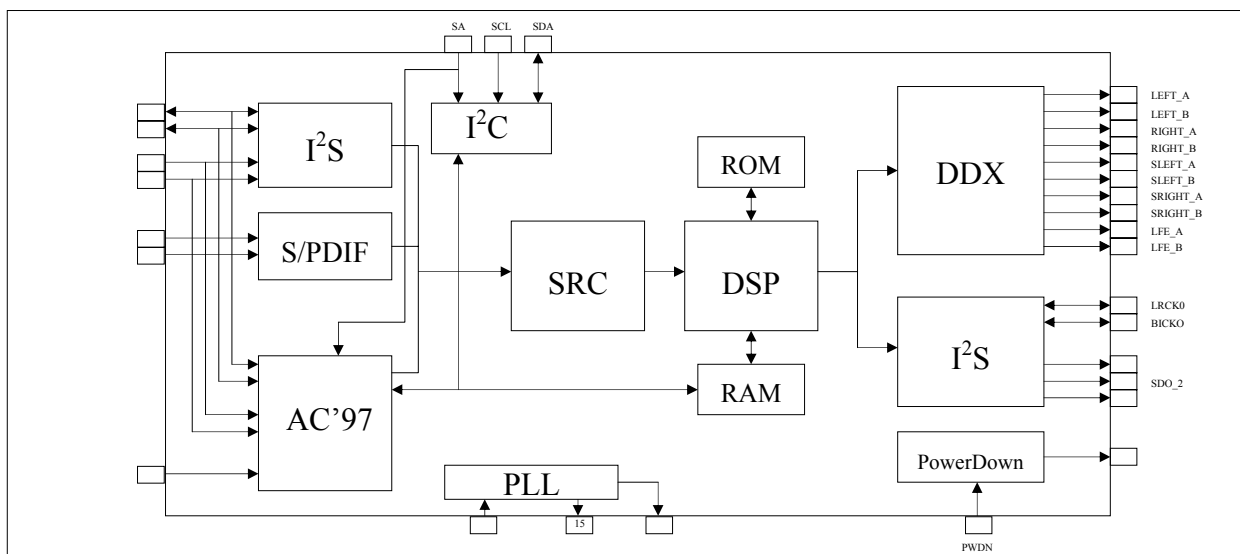

## 1.2 PIN FUNCTION

Table1

PIN	NAME	TYPE	DESCRIPTION	OUTPUT DRIVE
1	SDI_1/SDATA_OUT	I	Input I <sup>2</sup> S Serial Data 1/AC97 Output Data (I <sup>2</sup> S mode maps to L,R DDX)	
2	SDI_2/SDATA_IN	I/O	Input I <sup>2</sup> S Serial Data 2/AC97 Input Data (I <sup>2</sup> S mode maps to LS,RS DDX)	2mA
3	LRCKI/SYNC	I/O	Input I <sup>2</sup> S Left/Right Clock/AC97 Synch. Clock	2mA
4	BICKI/BIT_CLK	I/O	Input I <sup>2</sup> S Serial Clock/AC97 Bit Clock	4mA
5	VDD_1		Digital Supply Voltage	
6	GND_1		Digital Ground	
7	RESET	I	Global Reset (Active Low) This pin is sensed only after 2 clock cycles	CMOS Schmitt In Pull-Up
8	AC97_Mode	I	AC97 Enable/Disable (1=AC97; 0=I <sup>2</sup> S/SPDIF)	CMOS Schmitt In Pull-Down
9	SDA	I/O	I <sup>2</sup> C Serial Data	2mA
10	SCL	I	I <sup>2</sup> C Serial Clock	
11	SA	I	Select Address (I2C/AC97)	
12	N/C		Connect to ground or Leave open	CMOS In Pull-Down
13	VDD_2		Digital Supply Voltage	
14	XTI	I	Crystal Oscillator Input (Clock Input)	Analog IN
15	XTO	O	Crystal Oscillator Output Do Not Load	
16	GND_2		Digital Ground	
17	VCC		Analog Supply Voltage	
18	RXP	I	S/PDIF receiver positive (L,R DDX)	Analog In
19	RXN	I	S/PDIF receiver negative (L,R DDX)	Analog In
20	VSS		Analog Ground	
21	LFE_B	O	Pwm LFE (subwoofer) channel output (B)	3mA
22	LFE_A	O	Pwm LFE (subwoofer) channel output (A)	3mA
23	SRIGHT_B	O	Pwm Surround right channel output (B)	3mA
24	SRIGHT_A	O	Pwm Surround right channel output (A)	3mA
25	GND_3		Digital Ground	
26	VDD_3		Digital Supply Voltage	
27	RIGHT_B	O	Pwm Right channel output (B)	3mA
28	RIGHT_A	O	Pwm Right channel output (A)	3mA
29	LEFT_B	O	Pwm Left channel output (B)	3mA
30	LEFT_A	O	Pwm Left channel output (A)	3mA
31	GND_4		Digital Ground	
32	VDD_4		Digital Supply Voltage	
33	SLEFT_B	O	Pwm Surround Left channel output (B)	3mA
34	SLEFT_A	O	Pwm Surround Left channel output (A)	3mA
35	EAPD	O	External Amplifier Power down (Active Low)	3mA
36	LRCKO	I/O	I <sup>2</sup> S Left/Right Clock	2mA
37	SDO_1	O	I <sup>2</sup> S Serial Data 1 Output (L,R)	2mA
38	SDO_2	O	I <sup>2</sup> S Serial Data 2 Output (LS,RS)	2mA
39	SDO_3	O	I <sup>2</sup> S Serial Data 3 Output (C,SUB)	2mA
40	BICKO	I/O	I <sup>2</sup> S Serial Clock	4mA
41	GND_5		Digital Ground	
42	VDD_5		Digital Supply Voltage	
43	CKOUT	O	Clock Output (256fs or 512fs)	8mA
44	PWDN	I	Device Power down (Active Low)	CMOS In PullUp

## All-Digital High Efficiency Power Amplifier

### FEATURES

- HIGH OUTPUT CAPABILITY
- **2 x 50W** into 8Ω or **1 x 100W** into 4Ω
- SINGLE SUPPLY (+9V to +36V)
- SMALL PACKAGE
- HIGH EFFICIENCY, >88%
- THERMAL OVERLOAD AND SHORT CIRCUIT PROTECTION

### BENEFITS

- COMPLETE SURFACE MOUNT DESIGN
- POWER SUPPLY SAVINGS

### APPLICATIONS

- DIGITAL POWERED SPEAKERS
- PC SOUND CARDS
- CAR AUDIO
- SURROUND SOUND SYSTEMS
- DIGITAL AUDIO COMPONENTS

### GENERAL DESCRIPTION

The DDX-2100 power device is a monolithic dual channel H-Bridge that can provide up to 50 watts per channel of audio power at very high efficiency. The DDX-2100 power device contains a logic interface, integrated bridge drivers, high efficiency MOSFET output transistors and protection circuitry. The device may be used as a dual bridge or reconfigured as a single bridge with double the output current capability.

The benefits of the DDX amplification system are an all-digital design that eliminates the need for a digital to analog converter (DAC) and the high efficiency operation derived from the use of Apogee's patented damped ternary pulse width modulation (PWM). This approach provides an efficiency advantage over conventional Class-D designs and up to three times the efficiency of typical Class A/B amplifiers with music input signals.

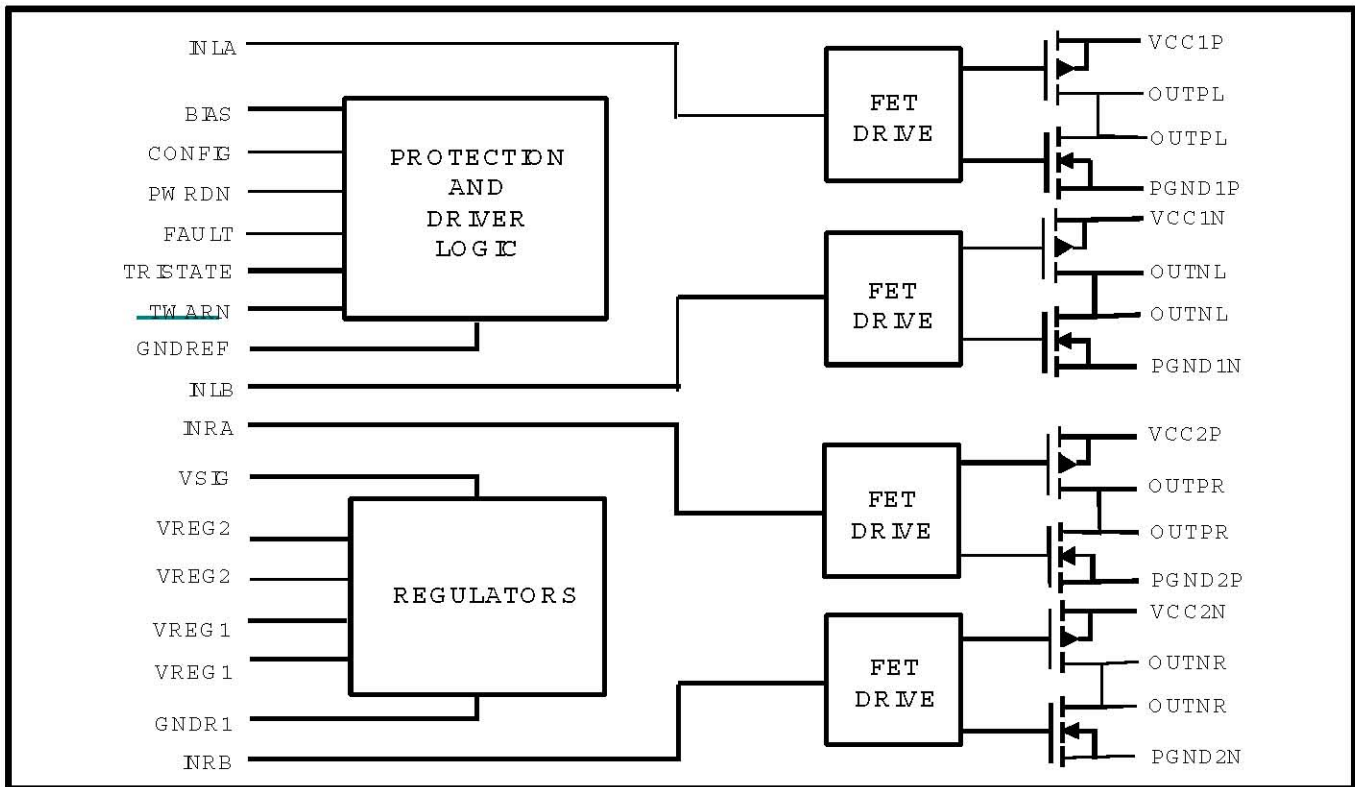

Figure 1 . B lock D iagram

## Electrical Characteristics (continued)

Note 1: Permanent device damage may occur if ABSOLUTE MAXIMUM RATINGS are exceeded. Exposure to absolute maximum rating conditions for extended periods may affect device reliability.

Note 2: Performance not guaranteed beyond recommended operating conditions.

Note 3: Characteristics are for the DDX-2100 power device driven by DDX-2000 processor.

### Logic Truth Table

TRISTATE	INxA	INxB	OUTPx	OUTNx	OUTPUT MODE
0	X	X	OFF	OFF	Hi-Z
1	0	0	GND	GND	DAMPED
1	0	1	GND	VCC	NEGATIVE
1	1	0	VCC	GND	POSITIVE
1	1	1	VCC	VCC	Not Used

## DDX-2100 Pin Function Description

### PWM Inputs

Pin Name	Pin No.	Description
INLA	29	Left A logic input signal
INLB	30	Left B logic input signal
INRA	31	Right A logic input signal
INRB	32	Right B logic input signal

### Control/Miscellaneous

Pin Name	Pin No.	Description
PWRDN	25	Power Down (0=Shutdown, 1= Normal).
TRI-STATE	26	Tri-State (0=All MOSFETS Hi-Z, 1=Normal).
FAULT [Note 4]	27	Fault output indicator; Overcurrent Overtemperature (0=Fault, 1=Normal).
TWARN [Note 4]	28	Thermal warning output (0=Warning $T_J \geq 130^\circ\text{C}$ , 1=Normal).
CONFIG [Note 5]	24	Configuration (0=Normal, 1=Parallel operation for mono).
NC	18	Do not connect.

### Power Outputs [Note 6]

Pin Name	Pin No.	Description
OUTPL	16, 17	Left output, positive reference
OUTNL	10, 11	Left output, negative reference
OUTPR	8, 9	Right output, positive reference
OUTNR	2, 3	Right output, negative reference

**Power Supplies**

<b>Pin Name</b>	<b>Pin No.</b>	<b>Description</b>
VCC [1P, 1N, 2P, 2N]	4, 7, 12, 15	Power
PGND [1P, 1N, 2P, 2N]	5, 6, 13, 14	Power grounds
VREG1	21, 22	Internal regulator voltage requires bypass capacitor.
VREG2	33, 34	Internal regulator voltage requires bypass capacitor.
VSIG	35, 36	Signal Positive supply.
VL	23	Logic reference voltage.
GNDREF	19	Logic reference ground.
GNDS	1	Substrate ground.
GNDR1	20	Internal regulator ground.

**PHYSICAL DIMENSIONS (Dimensions shown in mm)**

DIM.	mm			inch		
	MIN.	TYP.	MAX.	MIN.	TYP.	MAX.
A	3.25		3.5	0.128		0.138
A2		3.15			0.124	
A4	0.8		1	0.031		0.039
A5		0.2			0.008	
a1	0		0.1	0		0.004
b	0.22		0.38	0.008		0.015
c	0.23		0.32	0.009		0.012
D	15.8		16	0.622		0.630
D1	9.4		9.8	0.37		0.38
D2		1			0.039	
E	13.9		14.5	0.547		0.57
E1	10.9		11.1	0.429		0.437
E2			2.9			0.114
E3	5.8		6.2	0.228		0.244
E4	2.9		3.2	0.114		1.259
e		0.65			0.026	
e3		11.05			0.435	
G	0		0.1	0		0.004
H	15.5		15.9	0.61		0.625
h			1.1			0.043
L	0.8		1.1	0.031		0.043
N	10° (max)					
s	8° (max)					

**OUTLINE AND MECHANICAL DATA**

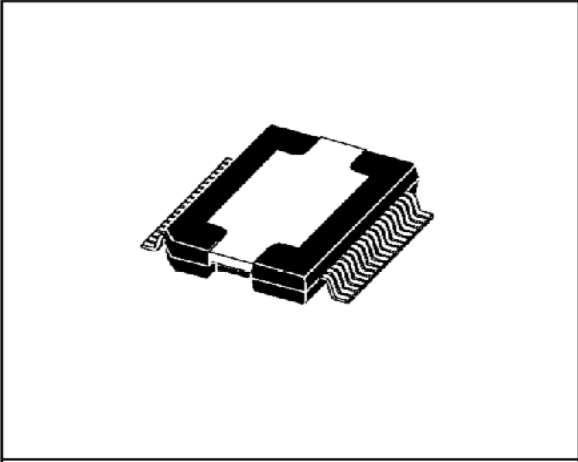

**PowerSO-36 (SLUG UP)**

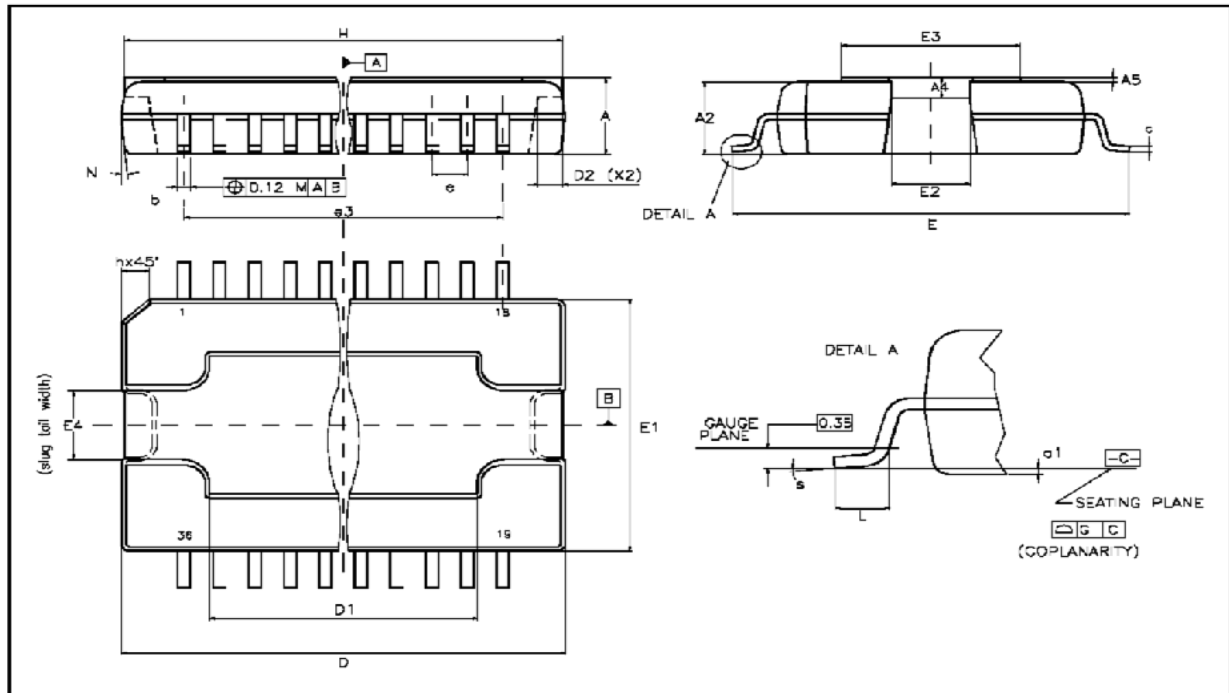



## IC DATA SHEET

AK4114VQ

= Target Spec =

## High Feature 192kHz 24bit Digital Audio Interface Transceiver

## GENERAL DESCRIPTION

The AK4114 is a digital audio transceiver supporting 192kHz, 24bits. The channel status decoder supports both consumer and professional modes. The AK4114 can automatically detect a Non-PCM bit stream. When combined with the AK4527 multichannel codec, the two chips provide a system solution for AC-3 applications. The dedicated pins or a serial  $\mu$ P I/F can control the mode setting. The small package, 48pin LQFP saves the system space.

\*AC-3 is a trademark of Dolby Laboratories.

## FEATURES

- AES3, IEC60958, S/PDIF, EIAJ CP1201 Compatible
- Low jitter Analog PLL
- PLL Lock Range : 32k~192kHz
- Clock Source: PLL or X'tal
- 8-channel Receiver input
- 2-channel Transmission output (Through output or DIT)
- Auxiliary digital input
- De-emphasis for 32kHz, 44.1kHz, 48kHz and 96kHz
- Detection Functions
  - Non-PCM Bit Stream Detection
  - DTS-CD Bit Stream Detection
  - Sampling Frequency Detection (32kHz, 44.1kHz, 48kHz, 88.2kHz, 96kHz, 176.4kHz, 192kHz)
  - Unlock & Parity Error Detection
  - Validity Flag Detection
- Up to 24bit Audio Data Format
- Audio I/F: Master or Slave Mode
- 40-bit Channel Status Buffer
- Burst Preamble bit Pc and Pd Buffer for Non-PCM bit stream
- Q-subcode Buffer for CD bit stream
- Serial  $\mu$ P I/F
- Two Master Clock Outputs: 64fs/128fs/256fs/512fs
- Operating Voltage: 2.7 to 3.6V with 5V tolerance
- Small Package: 48pin LQFP
- Ta: -10~70°C

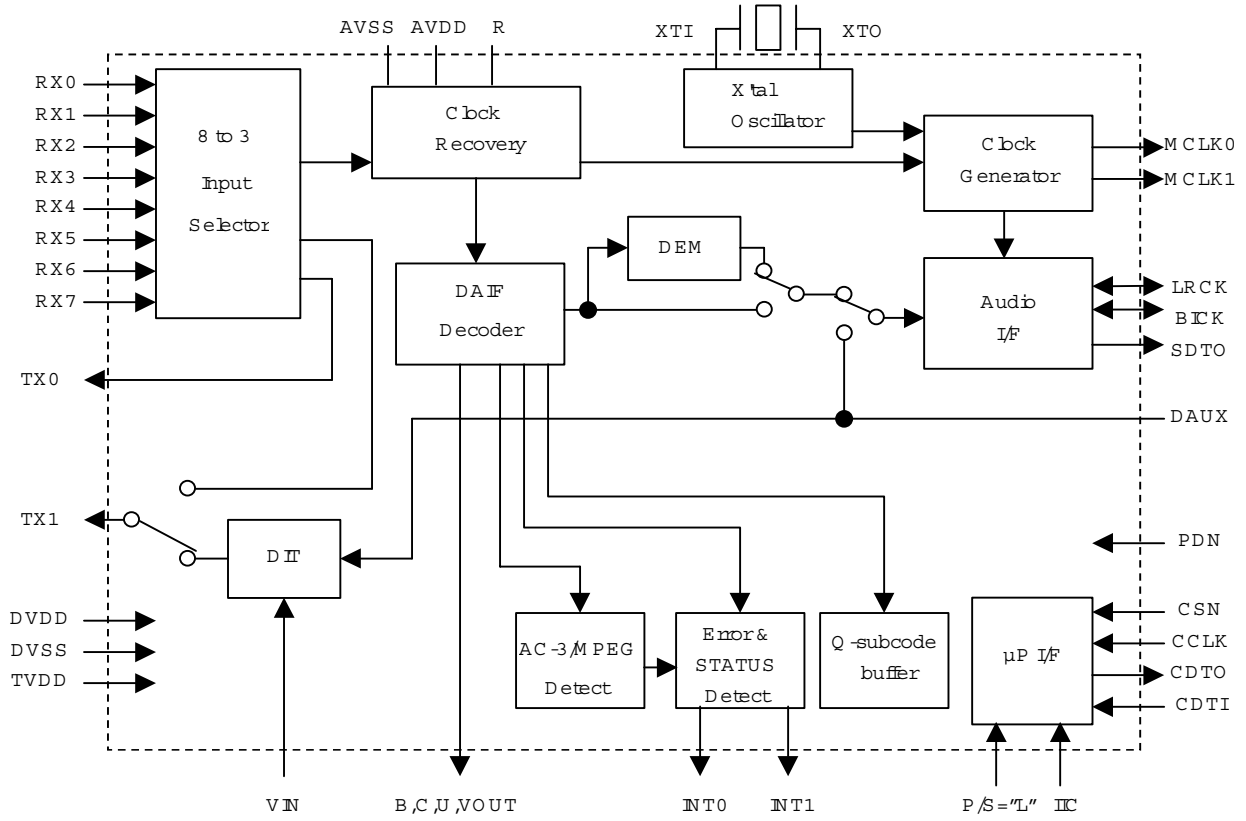

SerialControlM ode

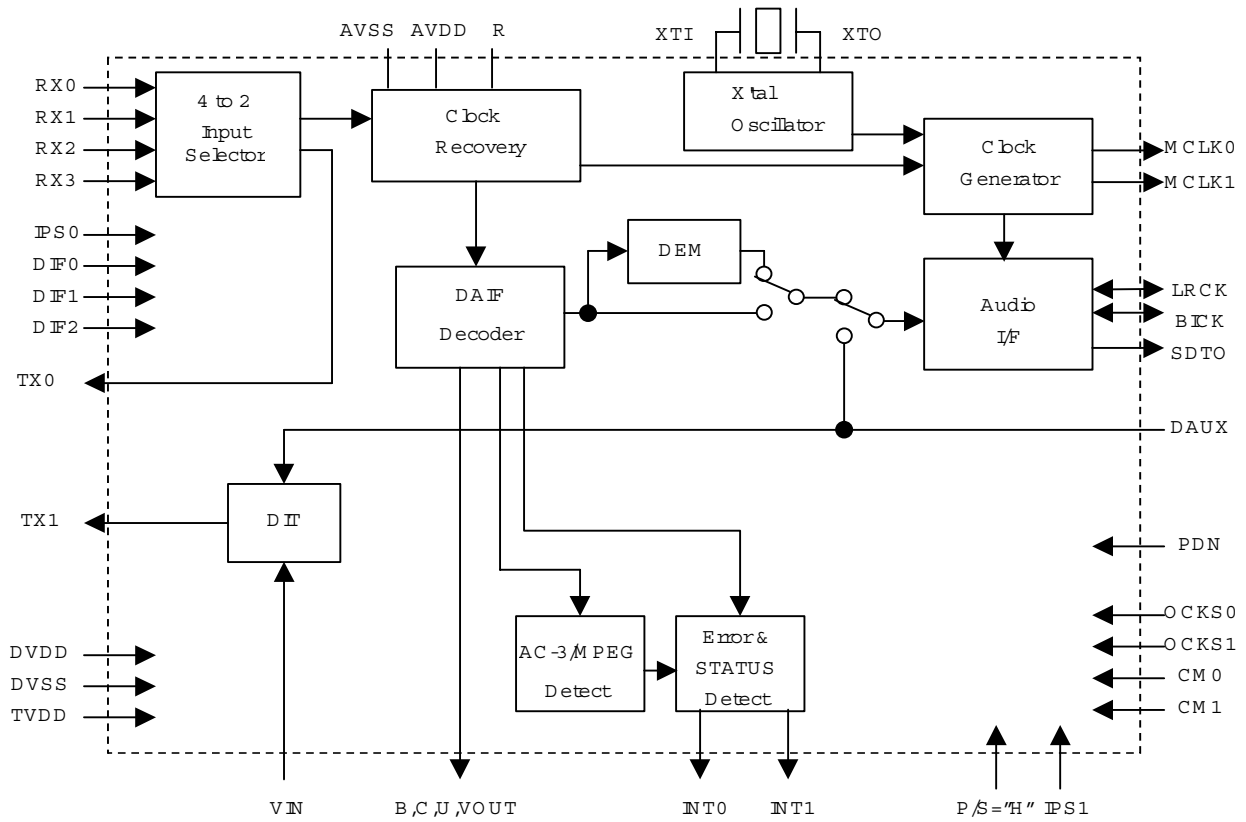

■ Ordering Guide

AK4114VQ

-10 ~ +70 °C

48pin LQFP (0.5mm pitch)

■ Pin Layout

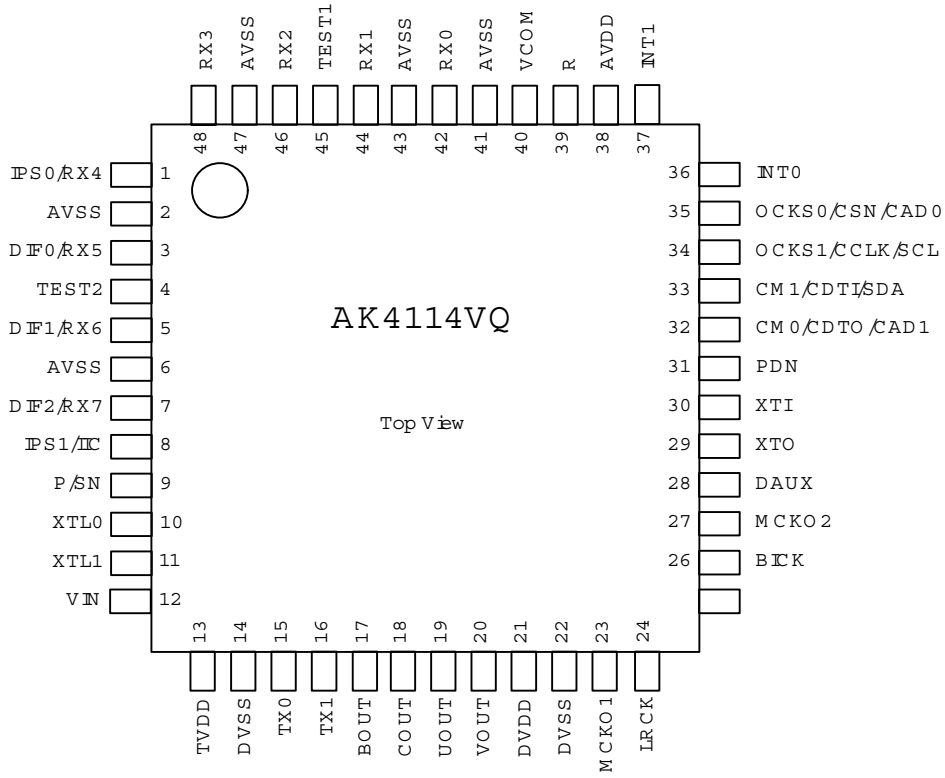

## M 4A 3 -32 /32

**FEATURES**

- ◆ **High-performance, E<sup>2</sup>CMOS 3.3-V & 5-V CPLD families**
- ◆ **Flexible architecture for rapid logic designs**
  - Excellent First-Time-Fit<sup>TM</sup> and refit feature
  - SpeedLocking<sup>TM</sup> performance for guaranteed fixed timing
  - Central, input and output switch matrices for 100% routability and 100% pin-out retention
- ◆ **High speed**
  - 5.0ns t<sub>PD</sub> Commercial and 7.5ns t<sub>PD</sub> Industrial
  - 182MHz f<sub>CNT</sub>
- ◆ **32 to 512 macrocells; 32 to 768 registers**
- ◆ **44 to 388 pins in PLCC, PQFP, TQFP, BGA, fpBGA and caBGA packages**
- ◆ **Flexible architecture for a wide range of design styles**
  - D/T registers and latches
  - Synchronous or asynchronous mode
  - Dedicated input registers
  - Programmable polarity
  - Reset/ preset swapping
- ◆ **Advanced capabilities for easy system integration**
  - 3.3-V & 5-V JEDEC-compliant operations
  - JTAG (IEEE 1149.1) compliant for boundary scan testing
  - 3.3-V & 5-V JTAG in-system programming
  - PCI compliant (-5/-55/-6/-65/-7/-10/-12 speed grades)
  - Safe for mixed supply voltage system designs
  - Programmable pull-up or Bus-Friendly<sup>TM</sup> inputs and I/Os
  - Hot-socketing
  - Programmable security bit
  - Individual output slew rate control
- ◆ **Advanced E<sup>2</sup>CMOS process provides high-performance, cost-effective solutions**
- ◆ **Supported by ispDesignEXPERT<sup>TM</sup> software for rapid logic development**
  - Supports HDL design methodologies with results optimized for ispMACH 4A
  - Flexibility to adapt to user requirements
  - Software partnerships that ensure customer success

## FUNCTIONAL DESCRIPTION

The fundamental architecture of ispMACH 4A devices (Figure 1) consists of multiple, optimized PAL<sup>®</sup> blocks interconnected by a central switch matrix. The central switch matrix allows communication between PAL blocks and routes inputs to the PAL blocks. Together, the PAL blocks and central switch matrix allow the logic designer to create large designs in a single device instead of having to use multiple devices.

The key to being able to make effective use of these devices lies in the interconnect schemes. In the ispMACH 4A architecture, the macrocells are flexibly coupled to the product terms through the logic allocator, and the I/O pins are flexibly coupled to the macrocells due to the output switch matrix. In addition, more input routing options are provided by the input switch matrix. These resources provide the flexibility needed to fit designs efficiently.

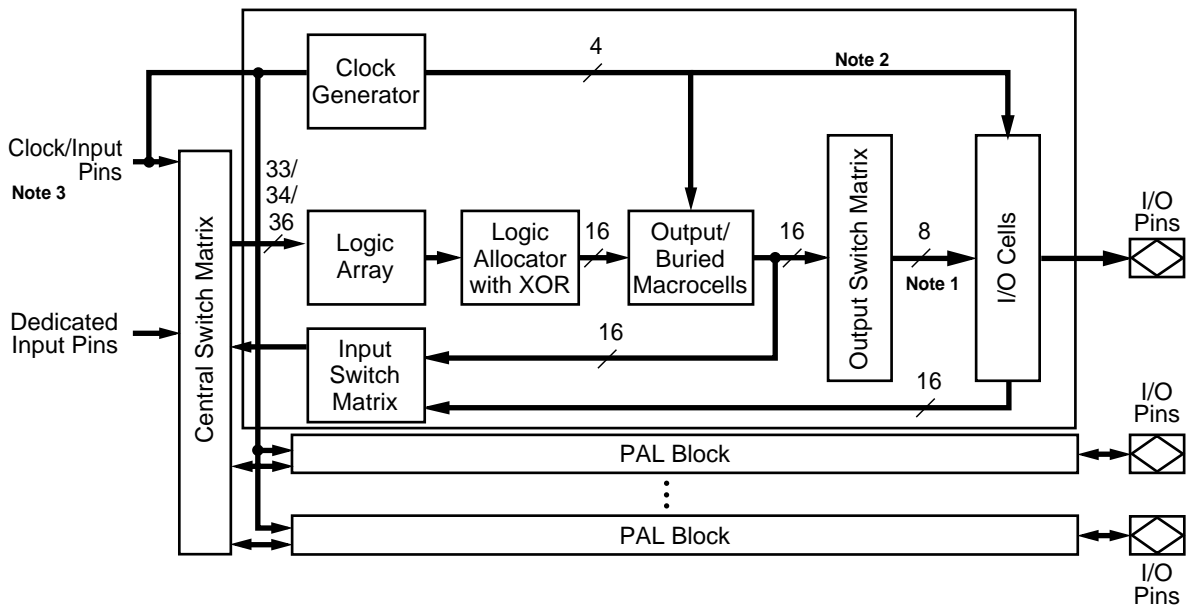

### Notes:

1. 16 for ispMACH 4A devices with 1:1 macrocell-I/O cell ratio (see next page).
2. Block clocks do not go to I/O cells in M4A(3,5)-32/32.
3. M4A(3,5)-192, M4A(3,5)-256, M4A3-384, and M4A3-512 have dedicated clock pins which cannot be used as inputs and do not connect to the central switch matrix.



### 44-PIN TQFP CONNECTION DIAGRAM (M4A(3,5)-32/32 AND M4A(3,5)-64/32)

#### Top View

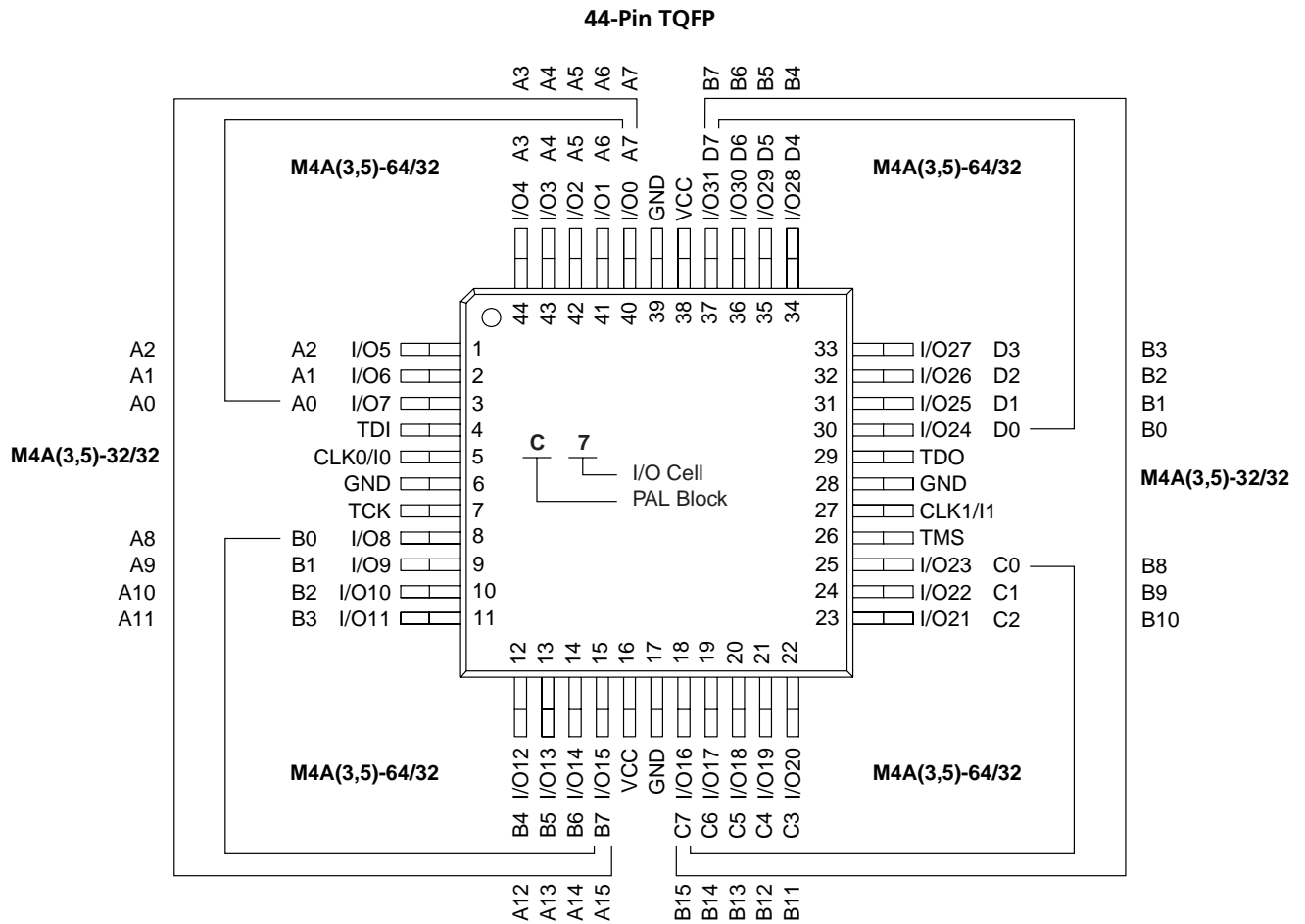

### PIN DESIGNATIONS

CLK/I = Clock or Input

GND = Ground

I/O = Input/Output

V<sub>CC</sub> = Supply Voltage

TDI = Test Data In

TCK = Test Clock

TMS = Test Mode Select

TDO = Test Data Out

## IRFP360

## HEXFET™ Power MOSFET

- Dynamic  $dv/dt$  Rating
- Repetitive Avalanche Rated
- Isolated Central Mounting Hole
- Fast Switching
- Ease of Paralleling
- Simple Drive Requirements

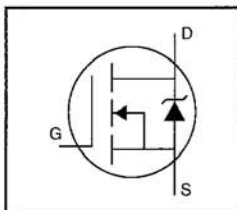

$$V_{DSS} = 400V$$

$$R_{DS(on)} = 0.20\Omega$$

$$I_D = 23A$$

**Description**

Third Generation HEXFETs from International Rectifier provide the designer with the best combination of fast switching, ruggedized device design, low on-resistance and cost-effectiveness.

The TO-247 package is preferred for commercial-industrial applications where higher power levels preclude the use of TO-220 devices. The TO-247 is similar but superior to the earlier TO-218 package because of its isolated mounting hole. It also provides greater creepage distance between pins to meet the requirements of most safety specifications.

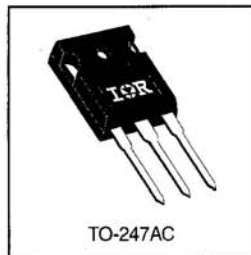

TO-247AC

**Absolute Maximum Ratings**

	Parameter	Max.	Units
$I_D @ T_C = 25^\circ C$	Continuous Drain Current, $V_{GS} @ 10 V$	23	A
$I_D @ T_C = 100^\circ C$	Continuous Drain Current, $V_{GS} @ 10 V$	14	
$I_{DM}$	Pulsed Drain Current ①	92	
$P_D @ T_C = 25^\circ C$	Power Dissipation	280	W
	Linear Derating Factor	2.2	W/°C
$V_{GS}$	Gate-to-Source Voltage	$\pm 20$	V
$E_{AS}$	Single Pulse Avalanche Energy ②	1200	mJ
$I_{AR}$	Avalanche Current ①	23	A
$E_{AR}$	Repetitive Avalanche Energy ①	28	mJ
$dv/dt$	Peak Diode Recovery $dv/dt$ ③	4.0	V/ns
$T_J$	Operating Junction and Storage Temperature Range	-55 to +150	°C
$T_{STG}$			
	Mounting Torque, 6-32 or M3 screw	10 lbf-in (1.1 N-m)	

**Thermal Resistance**

	Parameter	Min.	Typ.	Max.	Units
$R_{\theta JC}$	Junction-to-Case	—	—	0.45	°C/W
$R_{\theta CS}$	Case-to-Sink, Flat, Greased Surface	—	0.24	—	
$R_{\theta JA}$	Junction-to-Ambient	—	—	40	



# KA 3525A

## Features

- 5V ±1% Reference
- Oscillator Sync Terminal
- Internal Soft Start
- Deadtime Control
- Under Voltage Lockout

## Description

The KA 3525A is a monolithic integrated circuit that includes all of the control circuits necessary for a pulse width modulating regulator. There are a voltage reference, an error amplifier, a pulse width modulator, an oscillator, an under voltage lockout, a soft start circuit, and the output driver in the chip.

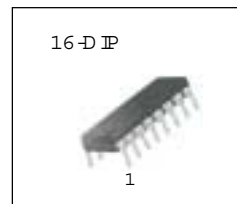

## Internal Block Diagram

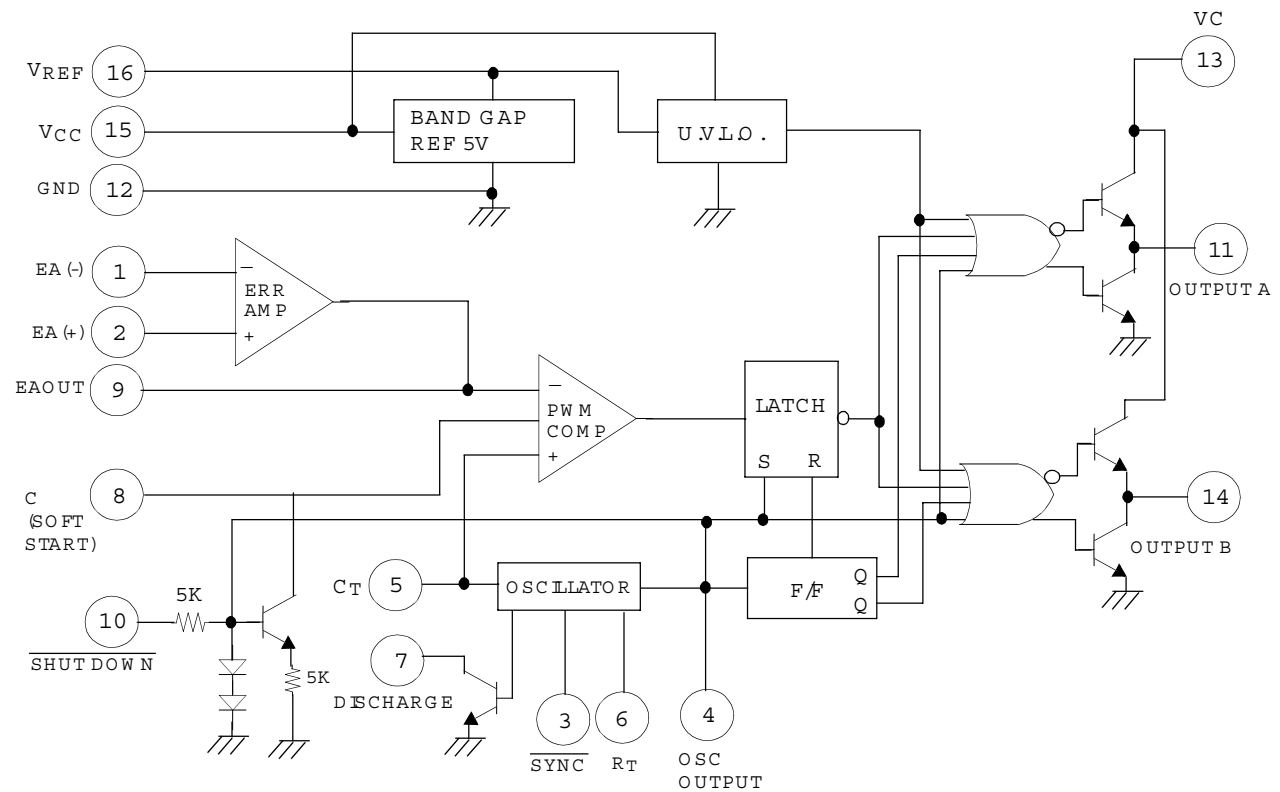

## Absolute Maximum Ratings

Parameter	Symbol	Value	Unit
Supply Voltage	V <sub>CC</sub>	40	V
Collector Supply Voltage	V <sub>C</sub>	40	V
Output Current, Sink or Source	I <sub>O</sub>	500	mA
Reference Output Current	I <sub>REF</sub>	50	mA
Oscillator Charging Current	I <sub>CHG (OSC)</sub>	5	mA
Power Dissipation (T <sub>A</sub> = 25°C)	P <sub>D</sub>	1000	mW
Operating Temperature	T <sub>OPR</sub>	0 ~ +70	°C
Storage Temperature	T <sub>STG</sub>	-65 ~ +150	°C
Lead Temperature (Soldering, 10sec)	T <sub>LEAD</sub>	+300	°C

## Electrical Characteristics

(V<sub>CC</sub> = 20V, T<sub>A</sub> = 0 to +70°C, unless otherwise specified)

Parameter	Symbol	Conditions	Min.	Typ.	Max.	Unit
REFERENCE SECTION						
Reference Output Voltage	V <sub>REF</sub>	T <sub>J</sub> = 25°C	5.0	5.1	5.2	V
Line Regulation	ΔV <sub>REF</sub>	V <sub>CC</sub> = 8 to 35V	-	9	20	mV
Load Regulation	ΔV <sub>REF</sub>	I <sub>REF</sub> = 0 to 20mA	-	20	50	mV
Short Circuit Output Current	I <sub>SC</sub>	V <sub>REF</sub> = 0, T <sub>J</sub> = 25°C	-	80	100	mA
Total Output Variation (Note1)	ΔV <sub>REF</sub>	Line, Load and Temperature	4.95	-	5.25	V
Temperature Stability (Note1)	ST <sub>T</sub>	-	-	20	50	mV
Long Term Stability (Note1)	ST	T <sub>J</sub> = 125°C, 1KHS	-	20	50	mV
OSCILLATOR SECTION						
Initial Accuracy (Note1, 2)	ACCUR	T <sub>J</sub> = 25°C	-	±3	±6	%
Frequency Change With Voltage	Δf/ΔV <sub>CC</sub>	V <sub>CC</sub> = 8 to 35V (Note1, 2)	-	±0.8	±2	%
Maximum Frequency	f <sub>(MAX)</sub>	R <sub>T</sub> = 2kΩ, C <sub>T</sub> = 470pF	400	430	-	kHz
Minimum Frequency	f <sub>(MIN)</sub>	R <sub>T</sub> = 200kΩ, C <sub>T</sub> = 0.1μF	-	60	120	Hz
Clbk Amplitude (Note1, 2)	V <sub>(CLK)</sub>	-	3	4	-	V
Clbk Width (Note1, 2)	t <sub>w</sub> (CLK)	T <sub>J</sub> = 25°C	0.3	0.6	1	μs
Sync Threshold	V <sub>TH (SYNC)</sub>	-	1.2	2	2.8	V
Sync Input Current	I <sub>(SYNC)</sub>	Sync = 3.5V	-	1.3	2.5	mA

# KA 7805

## Features

- Output Current up to 1A
- Output Voltages of 5, 6, 8, 9, 10, 12, 15, 18, 24V
- Thermal Overload Protection
- Short Circuit Protection
- Output Transistor Safe Operating Area Protection

## Description

The KA 78XX / KA 78XXA series of three-terminal positive regulators are available in the TO-220/D-PAK package and with several fixed output voltages, making them useful in a wide range of applications. Each type employs internal current limiting, thermal shut down and safe operating area protection, making it essentially indestructible. If adequate heat sinking is provided, they can deliver over 1A output current. Although designed primarily as fixed voltage regulators, these devices can be used with external components to obtain adjustable voltages and currents.

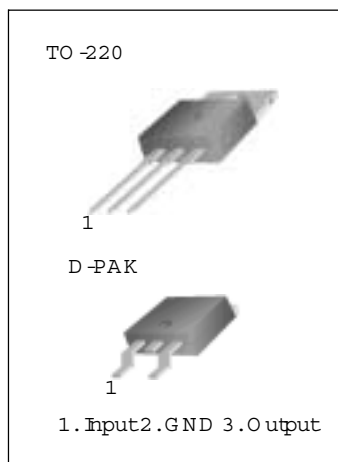

## Internal Block Diagram

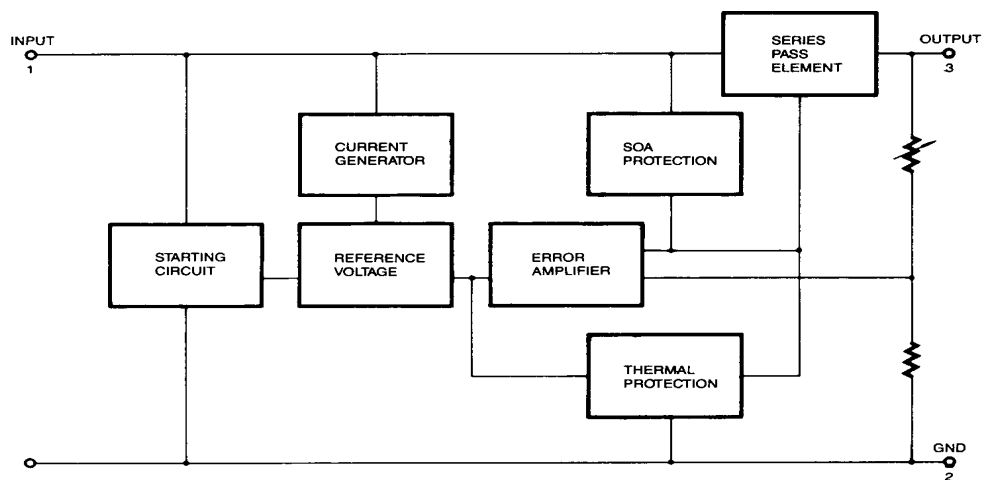

## Absolute Maximum Ratings

Parameter	Symbol	Value	Unit
Input Voltage (for $V_O = 5V$ to $18V$ ) (for $V_O = 24V$ )	$V_I$	35	V
	$V_I$	40	V
Thermal Resistance Junction-Cases (TO-220)	$R_{\theta JC}$	5	$^{\circ}C/W$
Thermal Resistance Junction-Air (TO-220)	$R_{\theta JA}$	65	$^{\circ}C/W$
Operating Temperature Range (KA78XXA/R)	$T_{OPR}$	0 ~ +125	$^{\circ}C$
Storage Temperature Range	$T_{STG}$	-65 ~ +150	$^{\circ}C$

## Electrical Characteristics (KA7805/KA7805R)

(Refer to test circuit,  $0^{\circ}C < T_J < 125^{\circ}C$ ,  $I_D = 500mA$ ,  $V_I = 10V$ ,  $C_F = 0.33\mu F$ ,  $C_O = 0.1\mu F$ , unless otherwise specified)

Parameter	Symbol	Conditions	KA7805			Unit	
			Min.	Typ.	Max.		
Output Voltage	$V_O$	$T_J = +25^{\circ}C$	4.8	5.0	5.2	V	
		$5.0mA \leq I_D \leq 1.0A$ , $P_O \leq 15W$ $V_I = 7V$ to $20V$	4.75	5.0	5.25		
Line Regulation (Note1)	Regline	$T_J = +25^{\circ}C$	$V_O = 7V$ to $25V$	-	4.0	100	mV
			$V_I = 8V$ to $12V$	-	1.6	50	
Load Regulation (Note1)	Regload	$T_J = +25^{\circ}C$	$I_D = 5.0mA$ to $1.5A$	-	9	100	mV
			$I_D = 250mA$ to $750mA$	-	4	50	
Quiescent Current	$I_Q$	$T_J = +25^{\circ}C$	-	5.0	8.0	mA	
Quiescent Current Change	$\Delta I_Q$	$I_D = 5mA$ to $1.0A$	-	0.03	0.5	mA	
		$V_I = 7V$ to $25V$	-	0.3	1.3		
Output Voltage Drift	$\Delta V_O / \Delta T$	$I_D = 5mA$	-	-0.8	-	mV/ $^{\circ}C$	
Output Noise Voltage	$V_N$	$f = 10Hz$ to $100kHz$ , $T_A = +25^{\circ}C$	-	42	-	$\mu V/V_O$	
Ripple Rejection	RR	$f = 120Hz$ $V_O = 8V$ to $18V$	62	73	-	dB	
Dropout Voltage	$V_{Dro}$	$I_D = 1A$ , $T_J = +25^{\circ}C$	-	2	-	V	
Output Resistance	$r_D$	$f = 1kHz$	-	15	-	m $\Omega$	
Short Circuit Current	$I_{SC}$	$V_I = 35V$ , $T_A = +25^{\circ}C$	-	230	-	mA	
Peak Current	$I_{PK}$	$T_J = +25^{\circ}C$	-	2.2	-	A	

Note:

1. Load and line regulation are specified at constant junction temperature. Changes in  $V_O$  due to heating effects must be taken into account separately. Pulse testing with low duty is used.

## KA7905

### Features

- Output Current in Excess of 1A
- Output Voltages of -5, -6, -8, -9, -10, -12, -15, -18, -24V
- Internal Thermal Overload Protection
- Short Circuit Protection
- Output Transistor Safe Operating Area Compensation

### Description

The KA79XX/KA79XXA series of three-terminal negative regulators are available in TO-220 package and with several fixed output voltages, making them useful in a wide range of applications. Each type employs internal current limiting, thermal shutdown and safe operating area protection, making it essentially indestructible.

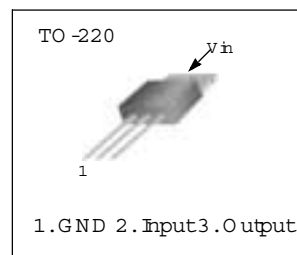

### Internal Block Diagram

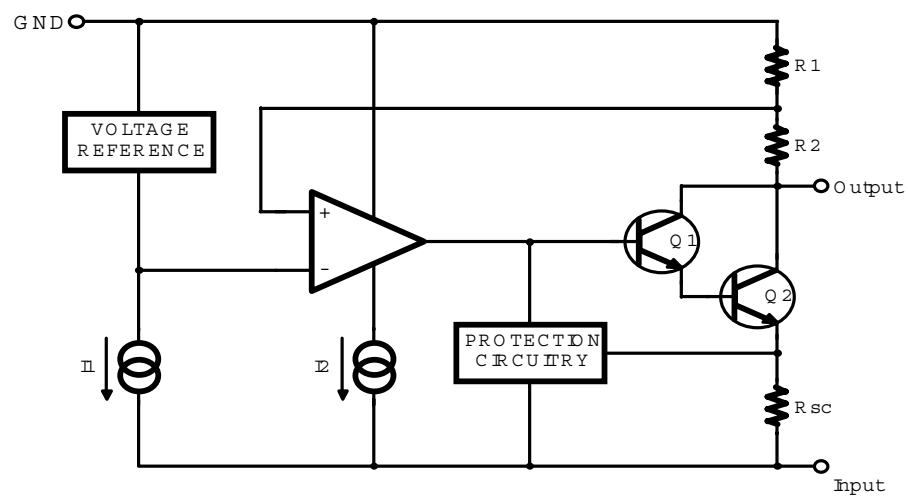

## Absolute Maximum Ratings

Parameter	Symbol	Value	Unit
Input Voltage	$V_I$	-35	V
Thermal Resistance Junction-Case (Note1)	$R_{\theta JC}$	5	$^{\circ}C/W$
Thermal Resistance Junction-Air (Note1, 2)	$R_{\theta JA}$	65	$^{\circ}C/W$
Operating Temperature Range	$T_{OPR}$	0 ~ +125	$^{\circ}C$
Storage Temperature Range	$T_{STG}$	-65 ~ +150	$^{\circ}C$

Note:

- Thermal resistance testboard  
Size: 76.2mm \* 114.3mm \* 1.6mm (LSOP)  
JEDEC standard: JESD51-3, JESD51-7
- Assume no ambient airflow

## Electrical Characteristics (KA7905)

( $V_I = -10V$ ,  $I_D = 500mA$ ,  $0^{\circ}C \leq T_J \leq +125^{\circ}C$ ,  $C_I = 2.2\mu F$ ,  $C_O = 1\mu F$ , unless otherwise specified.)

Parameter	Symbol	Conditions	Min.	Typ.	Max.	Unit	
Output Voltage	$V_O$	$T_J = +25^{\circ}C$	-4.8	-5.0	-5.2	V	
		$I_D = 5mA$ to 1A, $P_O \leq 15W$ $V_I = -7V$ to -20V	-4.75	-5.0	-5.25		
Line Regulation (Note3)	$\Delta V_O$	$T_J = +25^{\circ}C$	$V_I = -7V$ to -25V	-	35	100	mV
			$V_I = -8V$ to -12V	-	8	50	
Load Regulation (Note3)	$\Delta V_O$	$T_J = +25^{\circ}C$ , $I_D = 5mA$ to 1.5A	-	10	100	mV	
		$T_J = +25^{\circ}C$ , $I_D = 250mA$ to 750mA	-	3	50		
Quiescent Current	$I_Q$	$T_J = +25^{\circ}C$	-	3	6	mA	
Quiescent Current Change	$\Delta I_Q$	$I_D = 5mA$ to 1A	-	0.05	0.5	mA	
		$V_I = -8V$ to -25V	-	0.1	0.8		
Temperature Coefficient of $V_D$	$\Delta V_O/\Delta T$	$I_D = 5mA$	-	-0.4	-	mV/ $^{\circ}C$	
Output Noise Voltage	$V_N$	$f = 10Hz$ to 100kHz, $T_A = +25^{\circ}C$	-	40	-	$\mu V$	
Ripple Rejection	RR	$f = 120Hz$ , $\Delta V_I = 10V$	54	60	-	dB	
Dropout Voltage	$V_D$	$T_J = +25^{\circ}C$ , $I_D = 1A$	-	2	-	V	
Short Circuit Current	$I_{SC}$	$T_J = +25^{\circ}C$ , $V_I = -35V$	-	300	-	mA	
Peak Current	$I_{PK}$	$T_J = +25^{\circ}C$	-	2.2	-	A	

Note

- Load and line regulation are specified at constant junction temperature. Changes in  $V_O$  due to heating effects must be taken into account separately. Pulse testing with low duty is used.

SCHEMATICS

12 11 10 9 8 7 6 5 4 3 2 1

1. Front 1

DPR-1001 FRONT SCHEMATIC

3			2			1		
NO	DATE	POS.	CONTENTS	NO	DATE	POS.	CONTENTS	

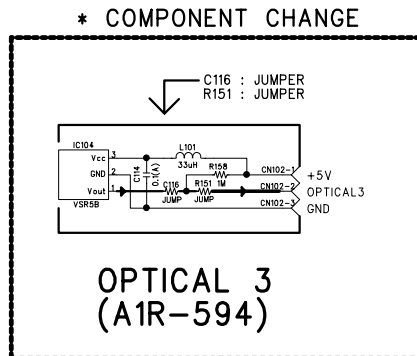
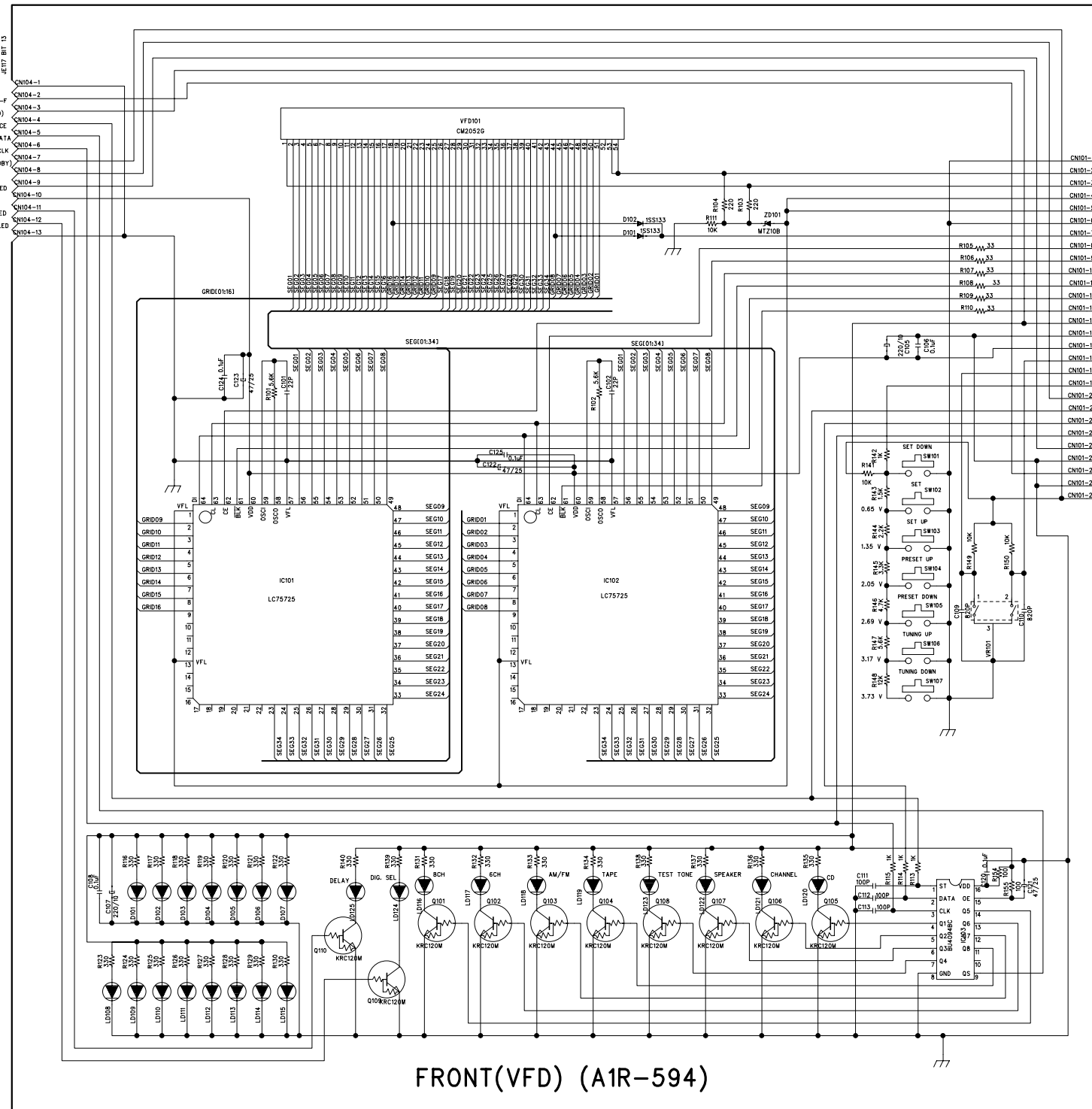

# DPR-1001 FRONT SCHEM

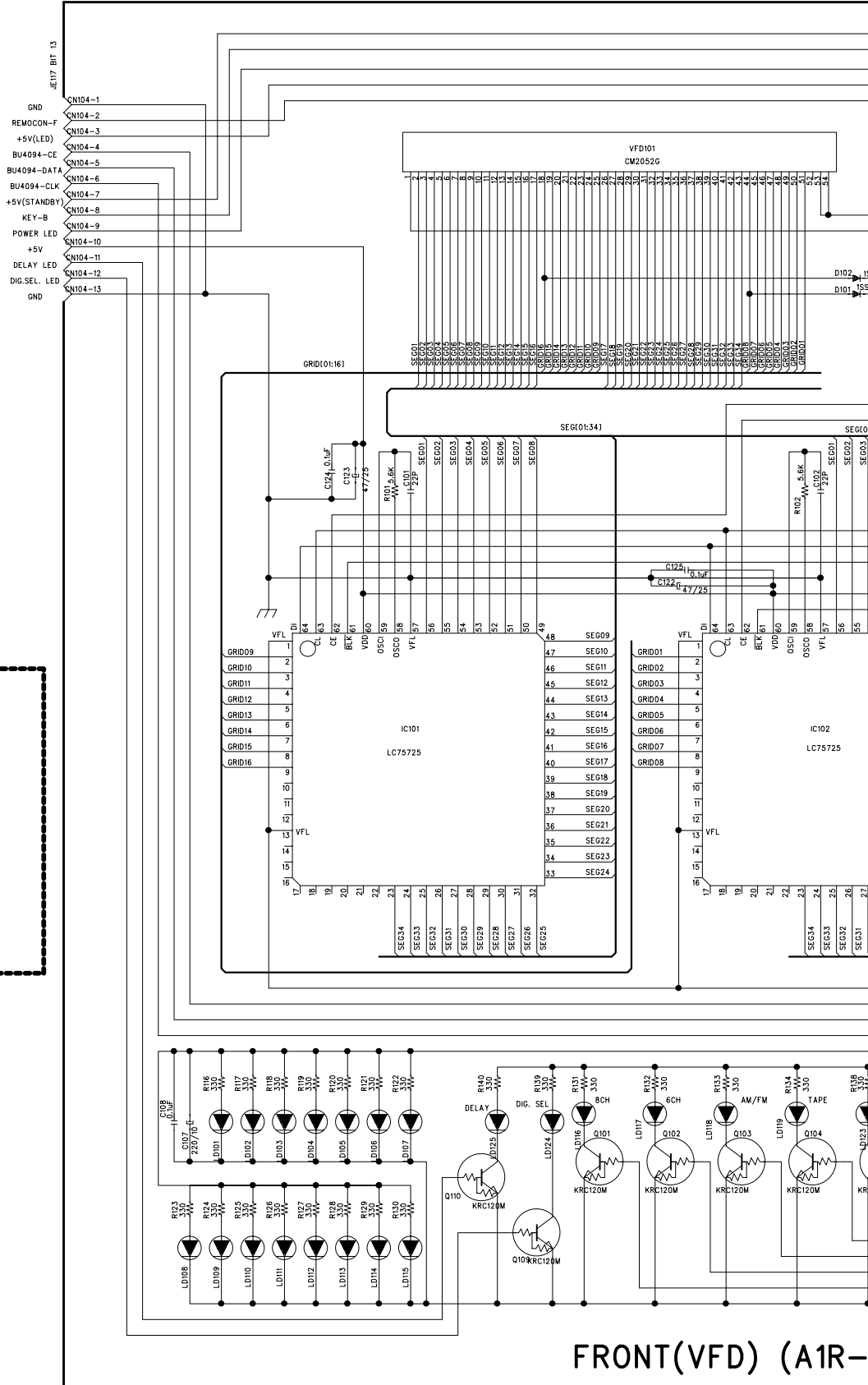

### \* COMPONENT CHANGE

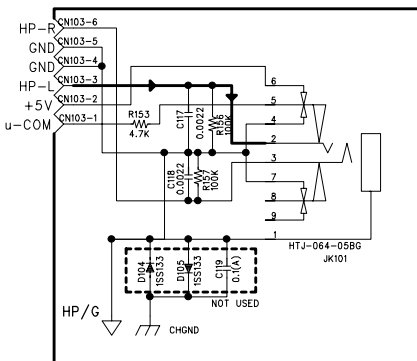
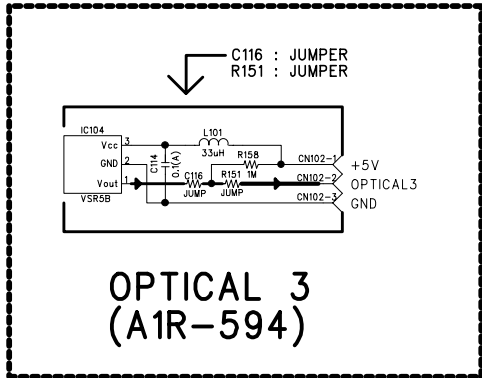

### FRONT(VFD) (A1R-594)



# OMATIC

## DPR1001

### harman/kardon

NO	DATE	POS.	CONTENTS	NO	DATE	POS.	CONTENTS

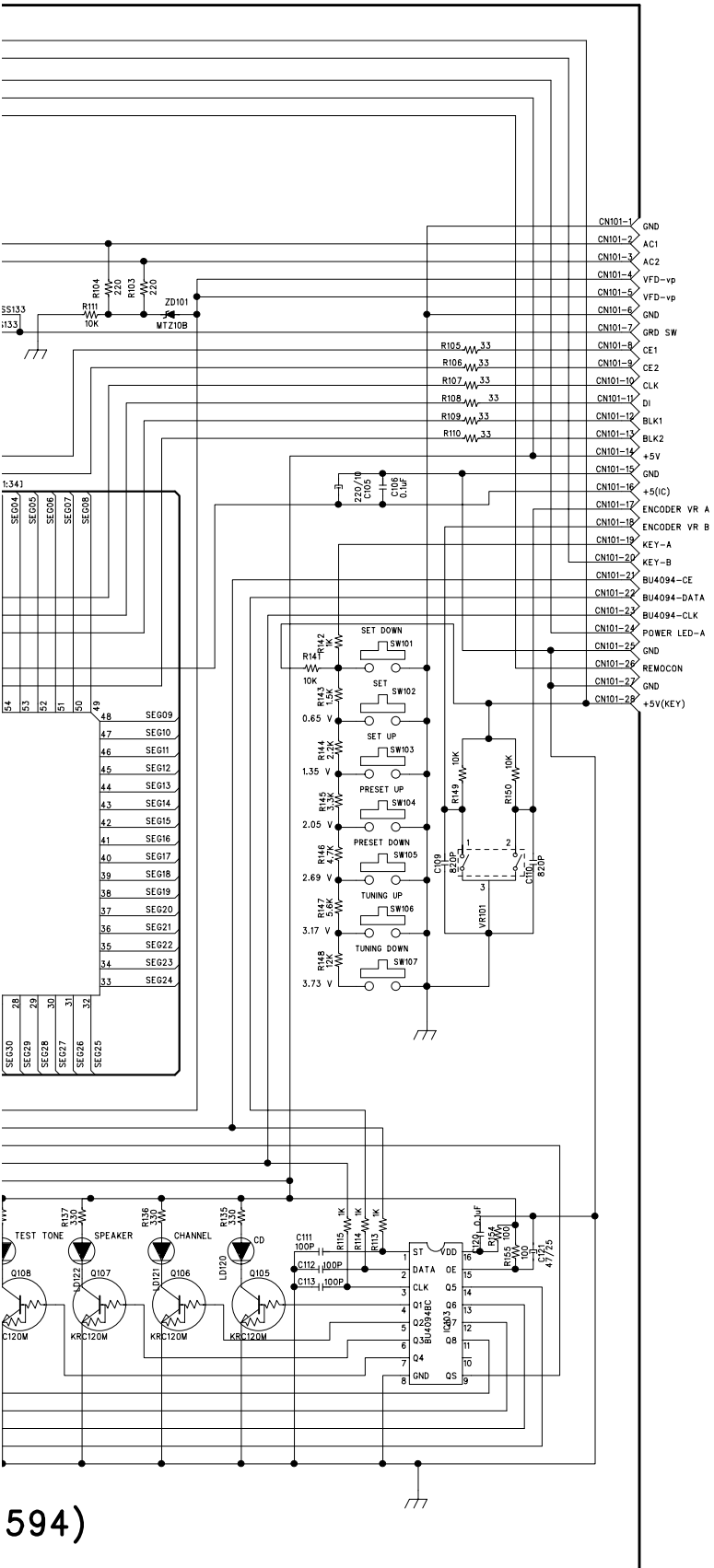

594)

CONFIDENTIAL/CONTROL COPY				
FILENAME	CODE NO.			SHEET /
MODEL	DESIGN	CHKD	CHKD	APPROVAL
DESIGN DATE				

**SCHEMATICS**

12	11	10	9	8	7	6	5	4	3	2	1
----	----	----	---	---	---	---	---	---	---	---	---

**2. Front 2**

DPR-1001 FRONT SCHEMATIC DIAGRAM

NO	DATE	POS.	CONTENTS	NO	DATE	POS.	CONTENTS

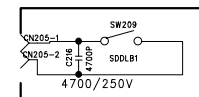
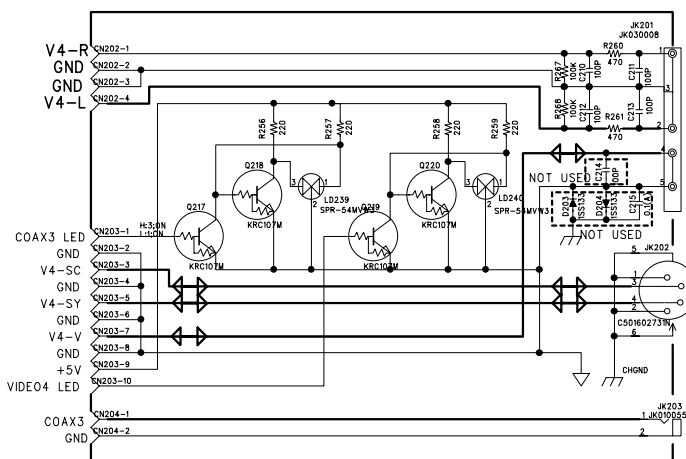
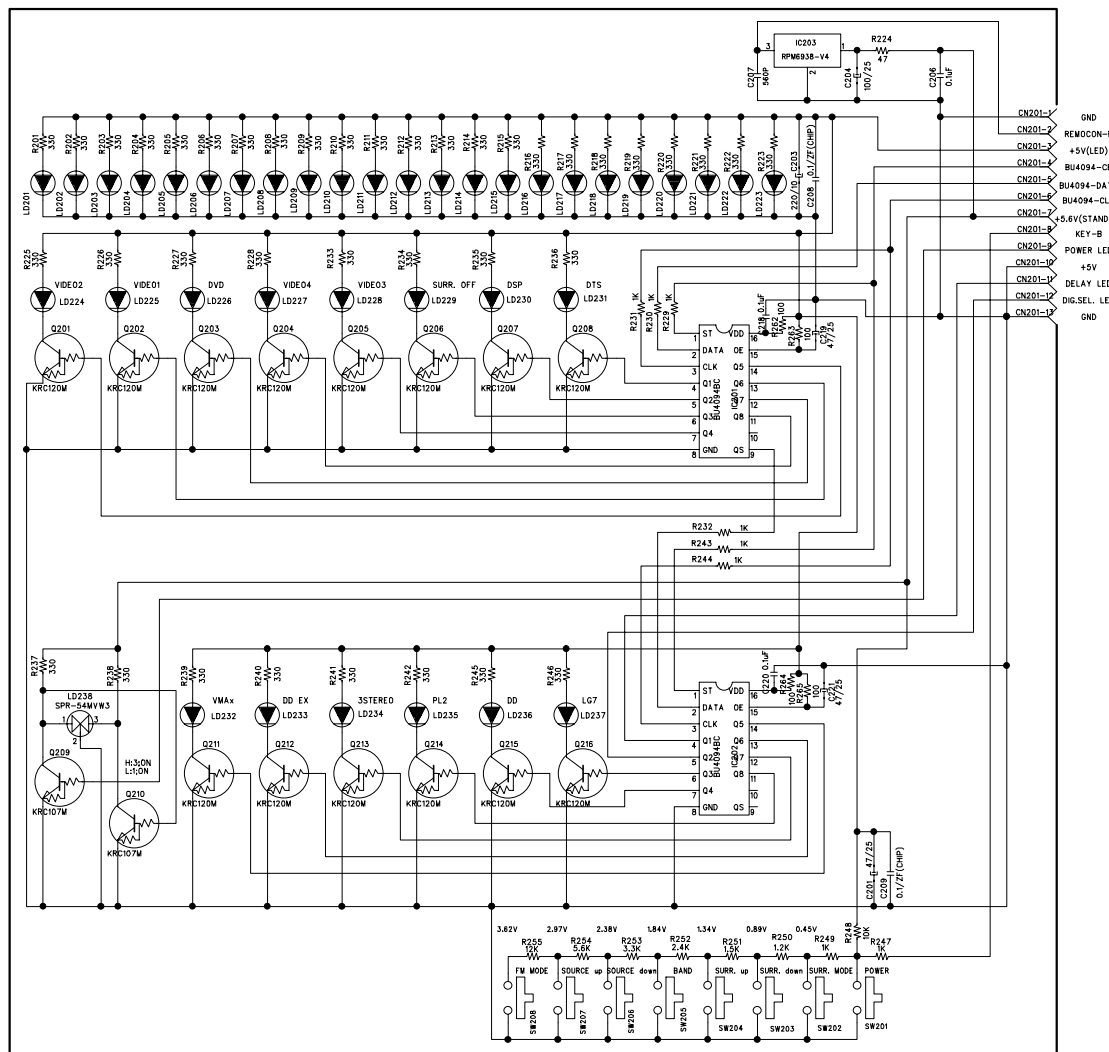

VIDEO4 B'D (A1R-603)

POWER KEY (A1R-603)

CONFIDENTIAL/CONTROL COPY				
FILENAME	CODE NO.	SHEET		
KEY_030205	A2AR-L2000-A3A			
MODEL	DESIGN	CHKD	CHKD	APPROVAL
DPR 1001				
DESIGN DATE	2003/02/07			



# DPR 1001/2001 MAIN SCHEMATIC

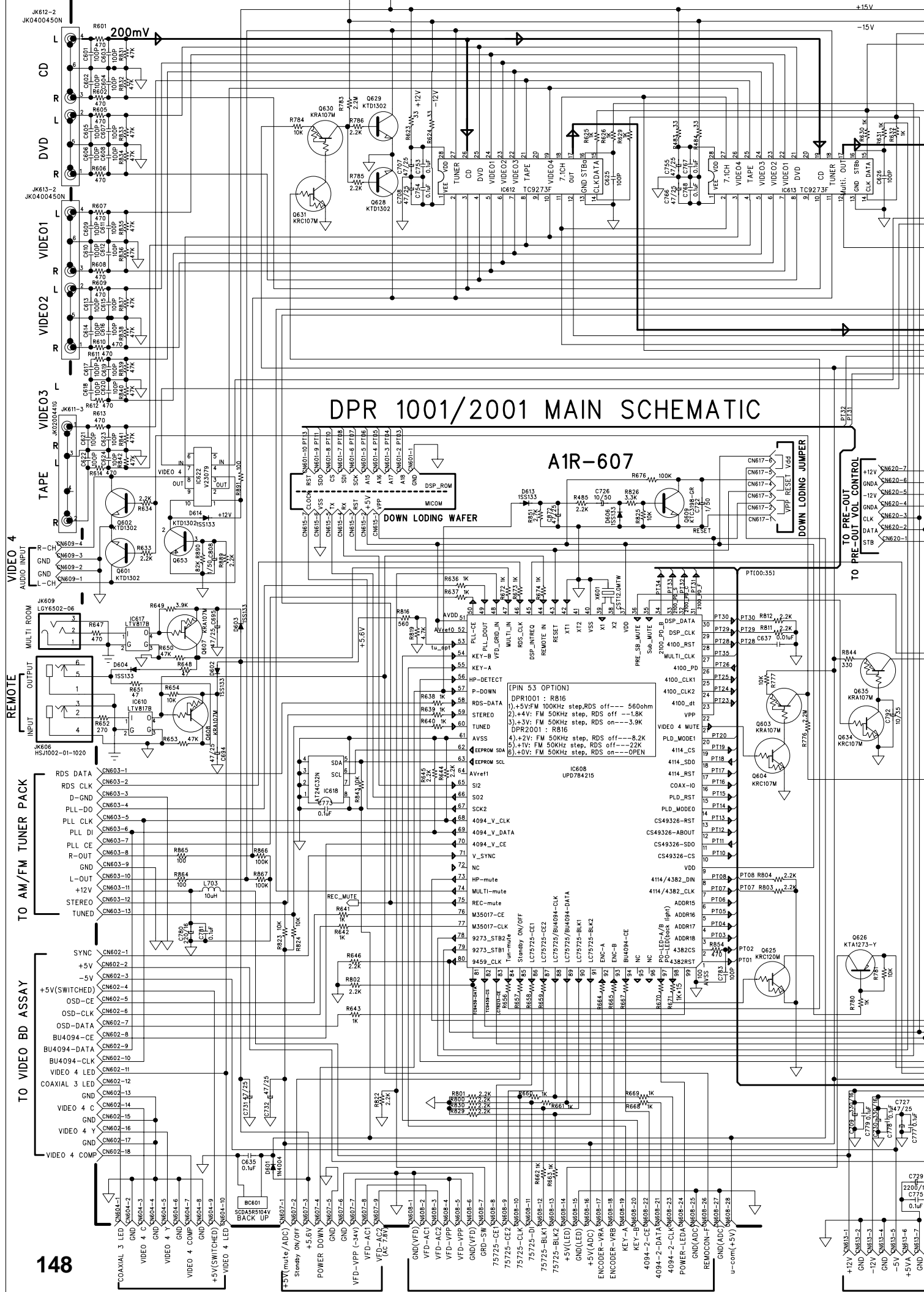

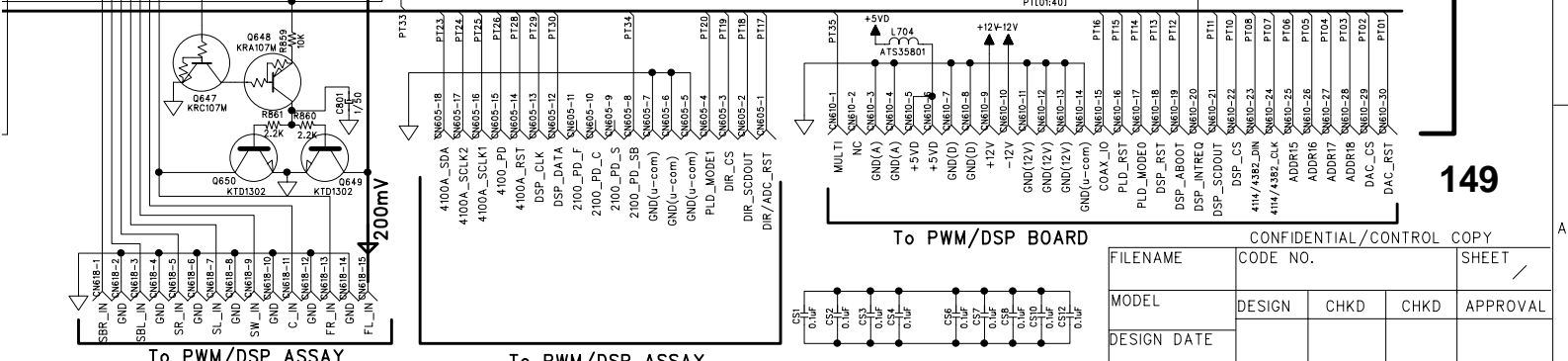
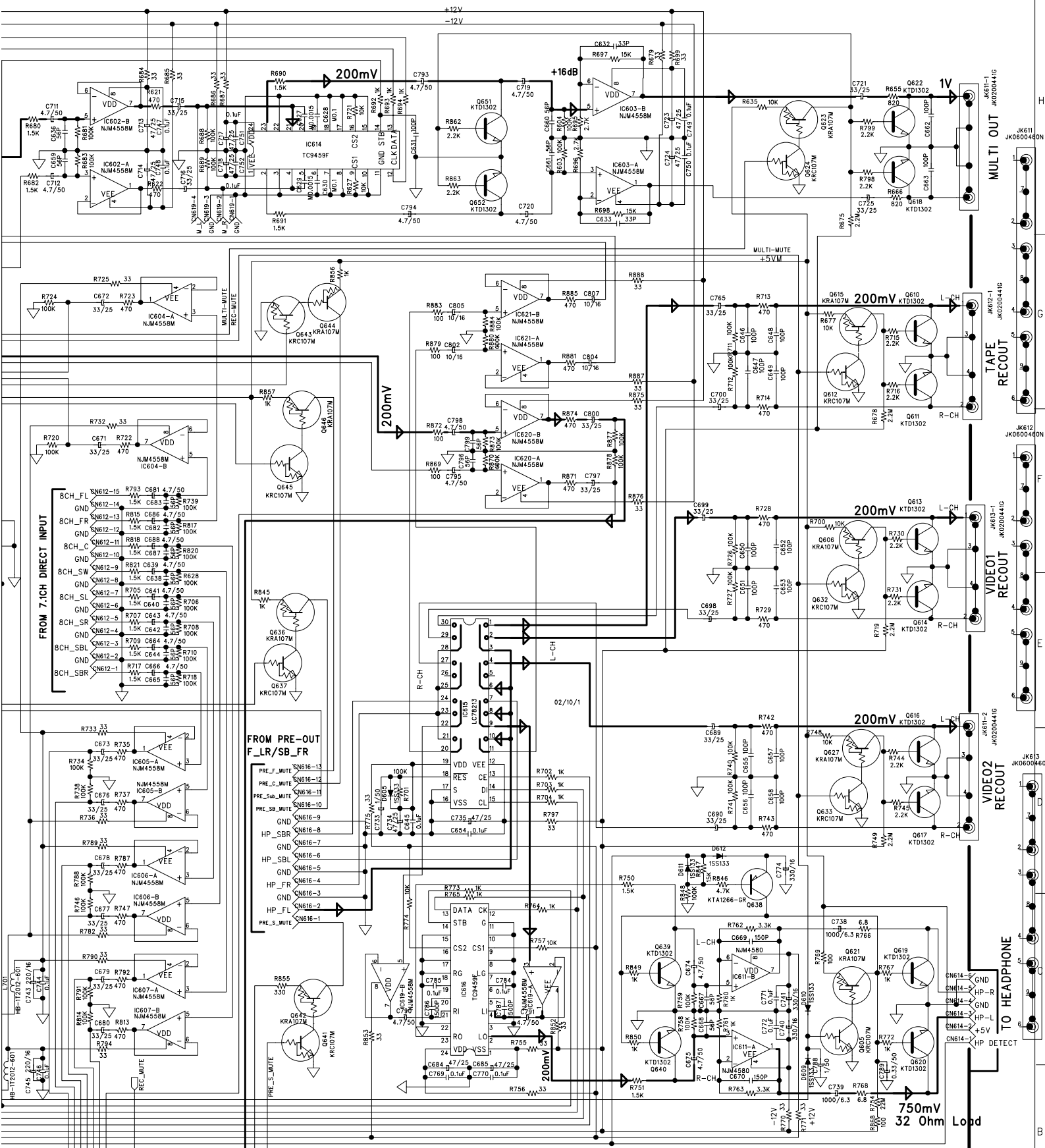

CONFIDENTIAL/CONTROL COPY

FILENAME	CODE NO.	SHEET	
MODEL	DESIGN	CHKD	APPROVAL
DESIGN DATE			

SCHEMATICS

4. DSP & PWM

DPR1001 DSP SCHEMATIC

NO	DATE	POS.	CONTENTS	NO	DATE	POS.	CONTENTS

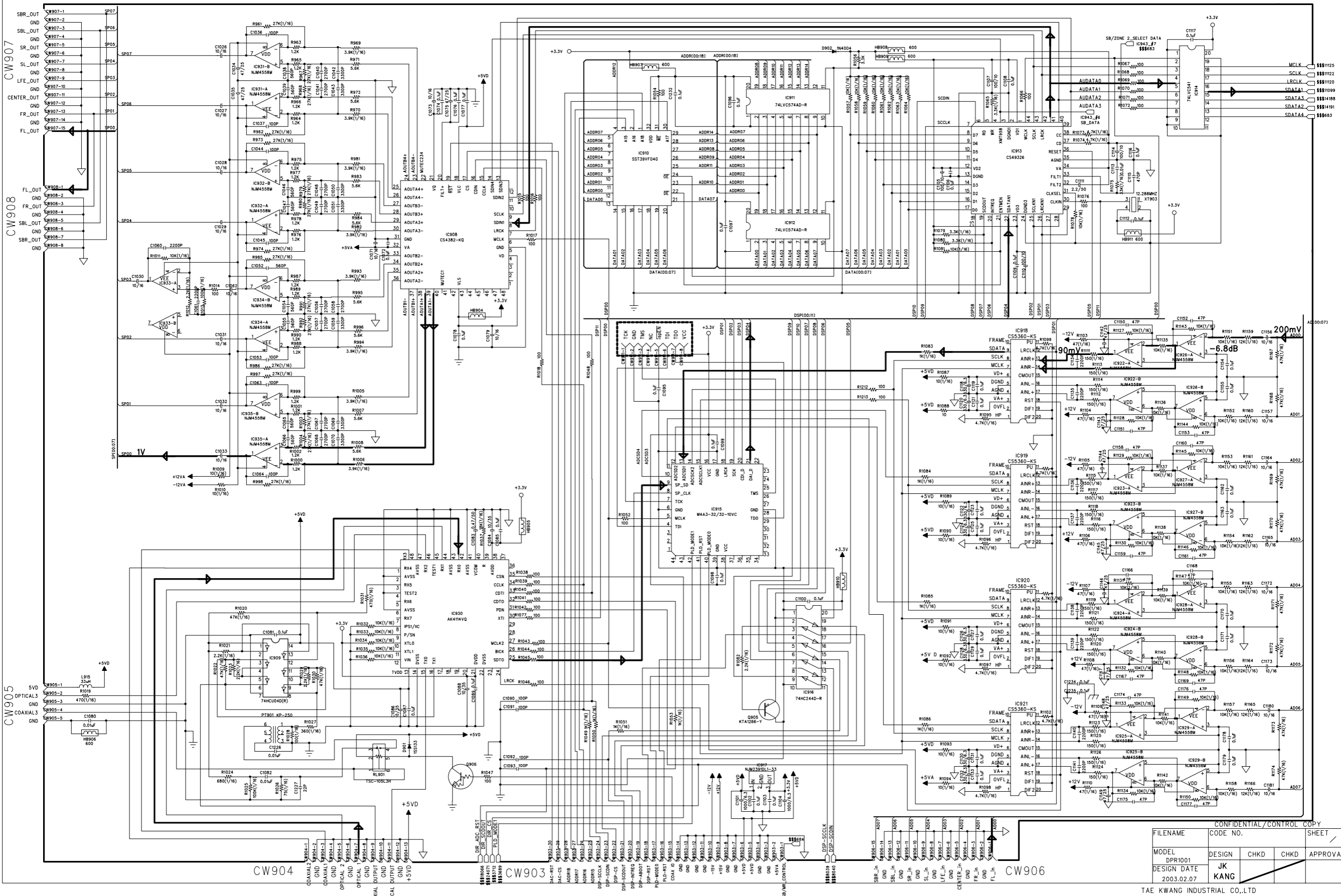

FILENAME	CODE NO.	SHEET
DPR1001		

MODEL	DESIGN	CHKD	CHKD	APPROVAL
DPR1001	JK			

DESIGN DATE: 2003.02.07

TAE KWANG INDUSTRIAL CO., LTD

DPR1001

harman/kardon

DPR1001 DS

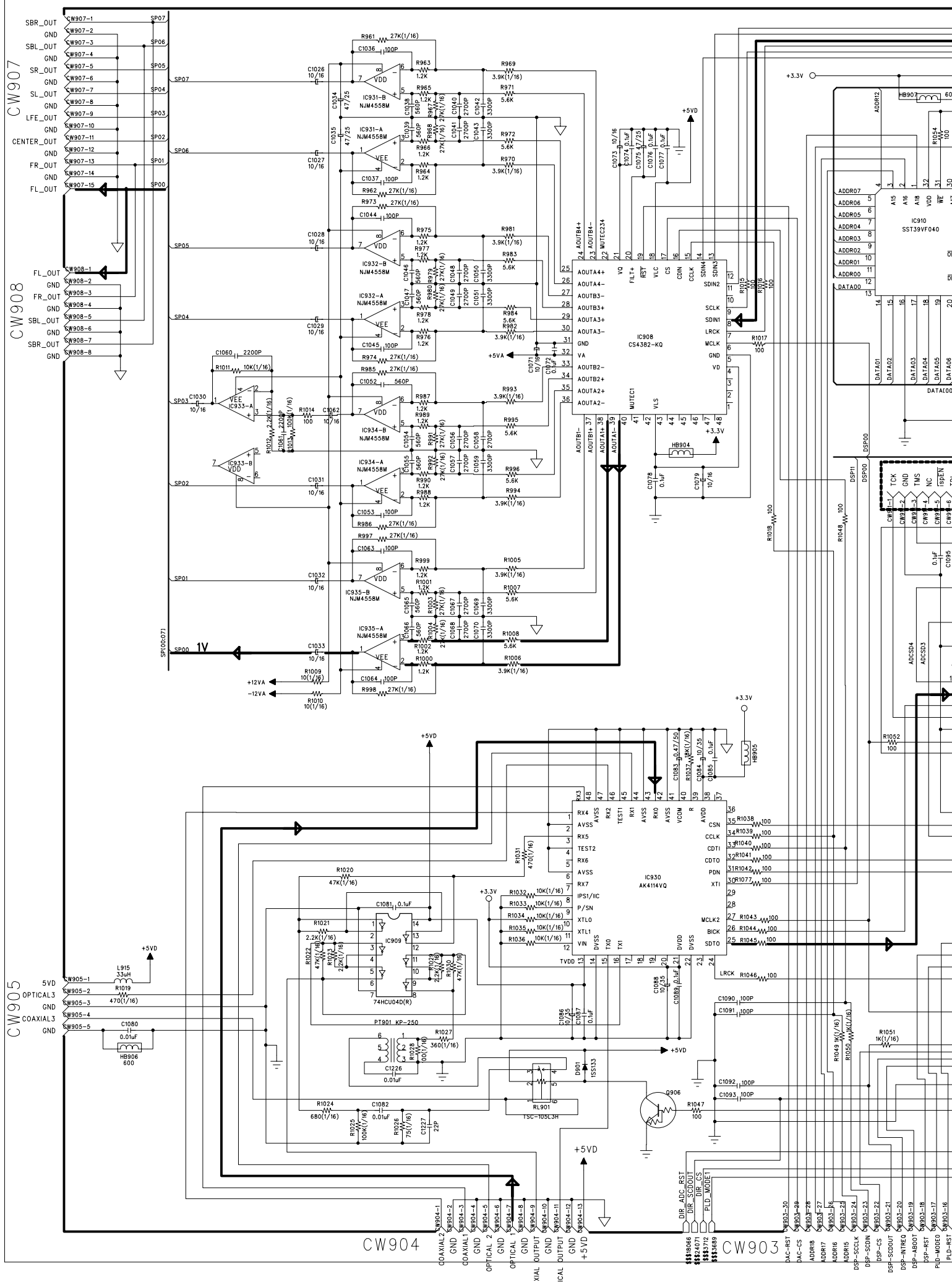





SCHEMATICS

4. DSP & PWM

DPR1001 PWM AMP SCHEMATIC

NO	DATE	POS.	CONTENTS	NO	DATE	POS.	CONTENTS

CW901

CW902

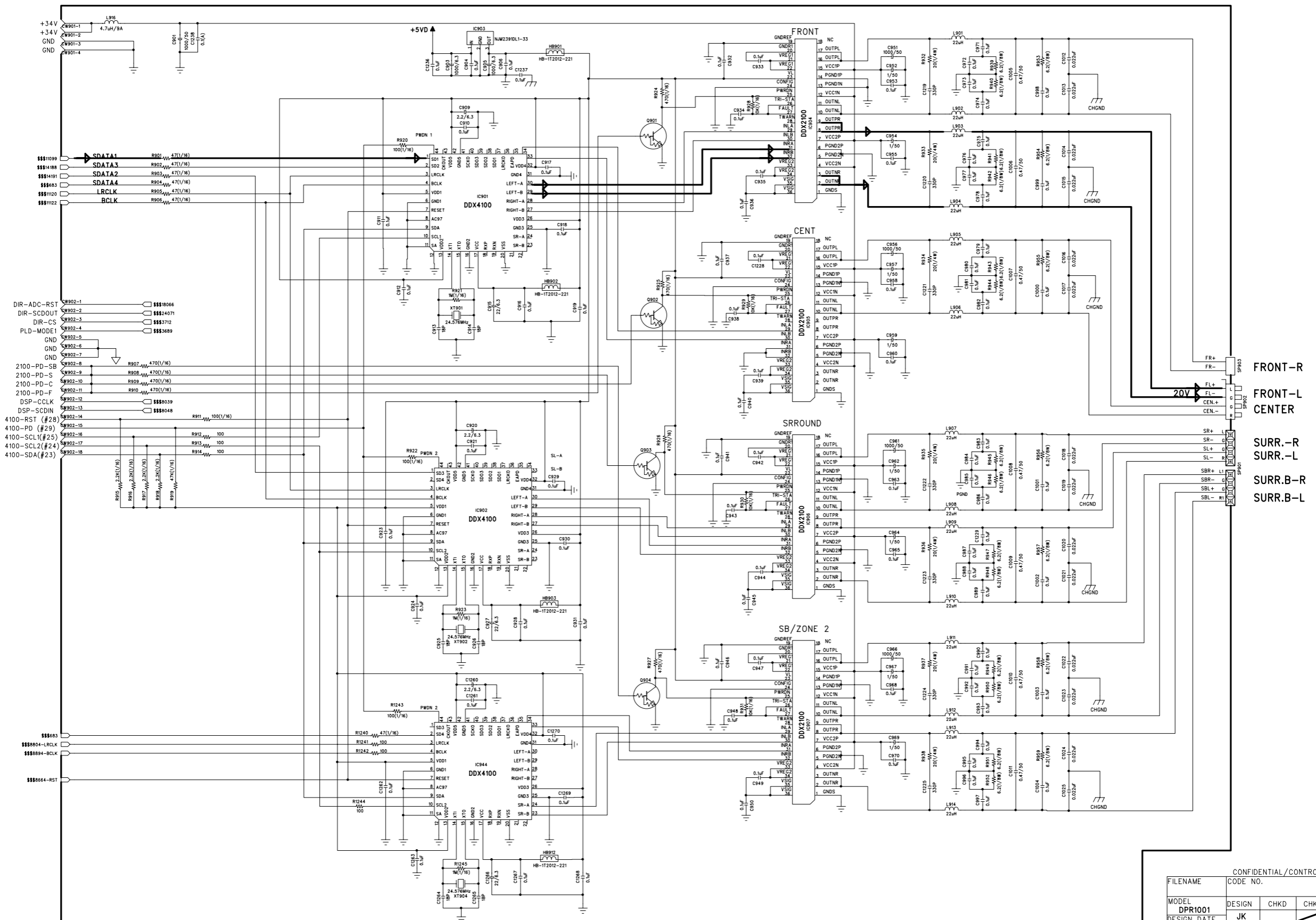

CONFIDENTIAL/CONTROL COPY				
FILENAME	CODE NO.	CHKD	CHKD	APPROVAL
MODEL DPR1001	DESIGN JK			
DESIGN DATE 2003.02.07	KANG			

CW901

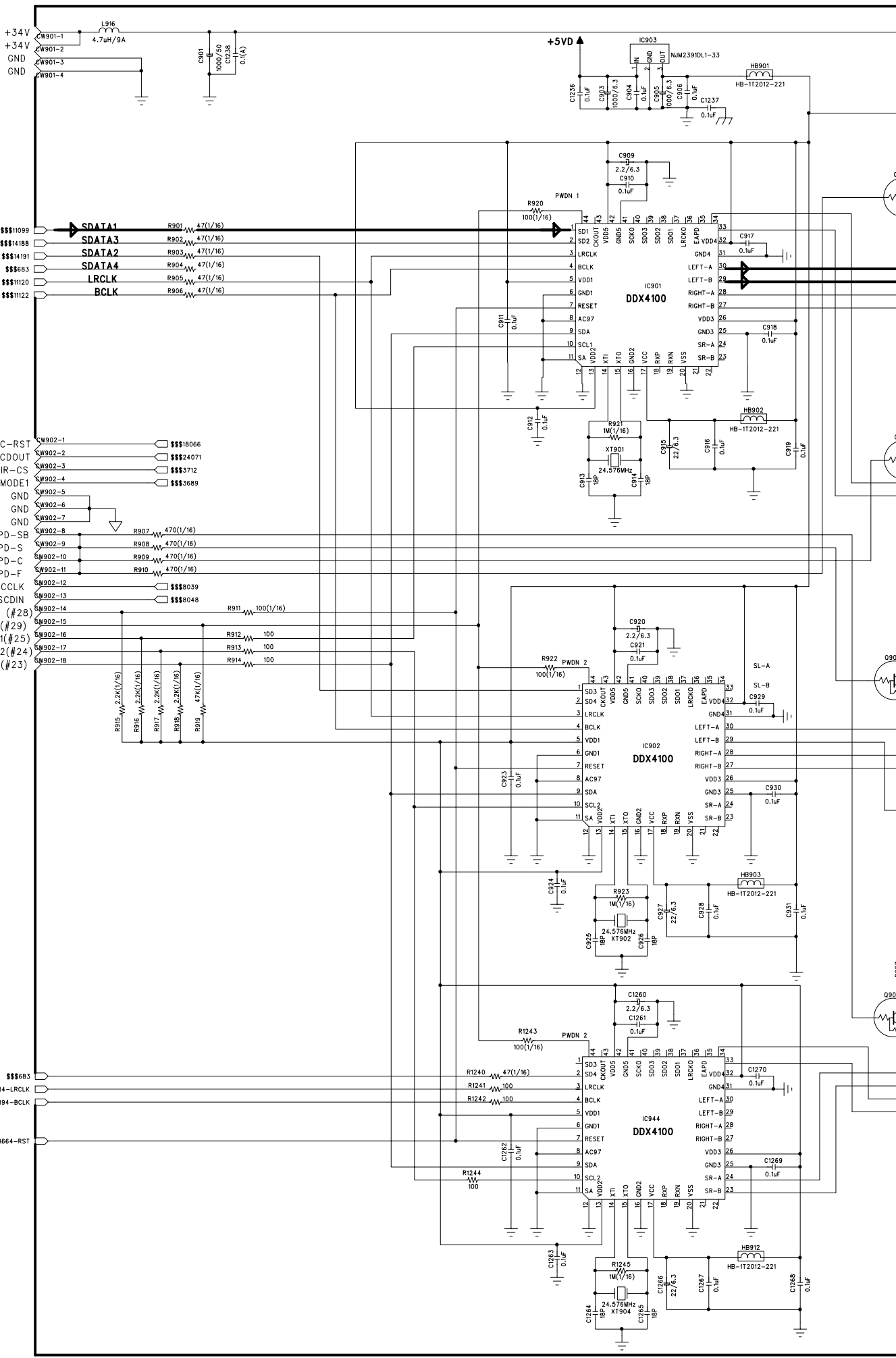

CW902

- DIR-ADC-RST CW902-1
- DIR-SCDOUT CW902-2
- DIR-CS CW902-3
- PLD-MODE1 CW902-4
- GND CW902-5
- GND CW902-6
- GND CW902-7
- 2100-PD-SB CW902-8
- 2100-PD-S CW902-9
- 2100-PD-C CW902-10
- 2100-PD-F CW902-11
- DSP-CCLK CW902-12
- DSP-SCDIN CW902-13
- 4100-RST (#28) CW902-14
- 4100-PD (#29) CW902-15
- 4100-SCL1 (#25) CW902-16
- 4100-SCL2 (#24) CW902-17
- 4100-SDA (#23) CW902-18

- \$\$\$683
- \$\$\$804-LRCLK
- \$\$\$894-BCLK
- \$\$\$8664-RST

# AMP SCHEMATIC

## DPR1001

harman/kardon

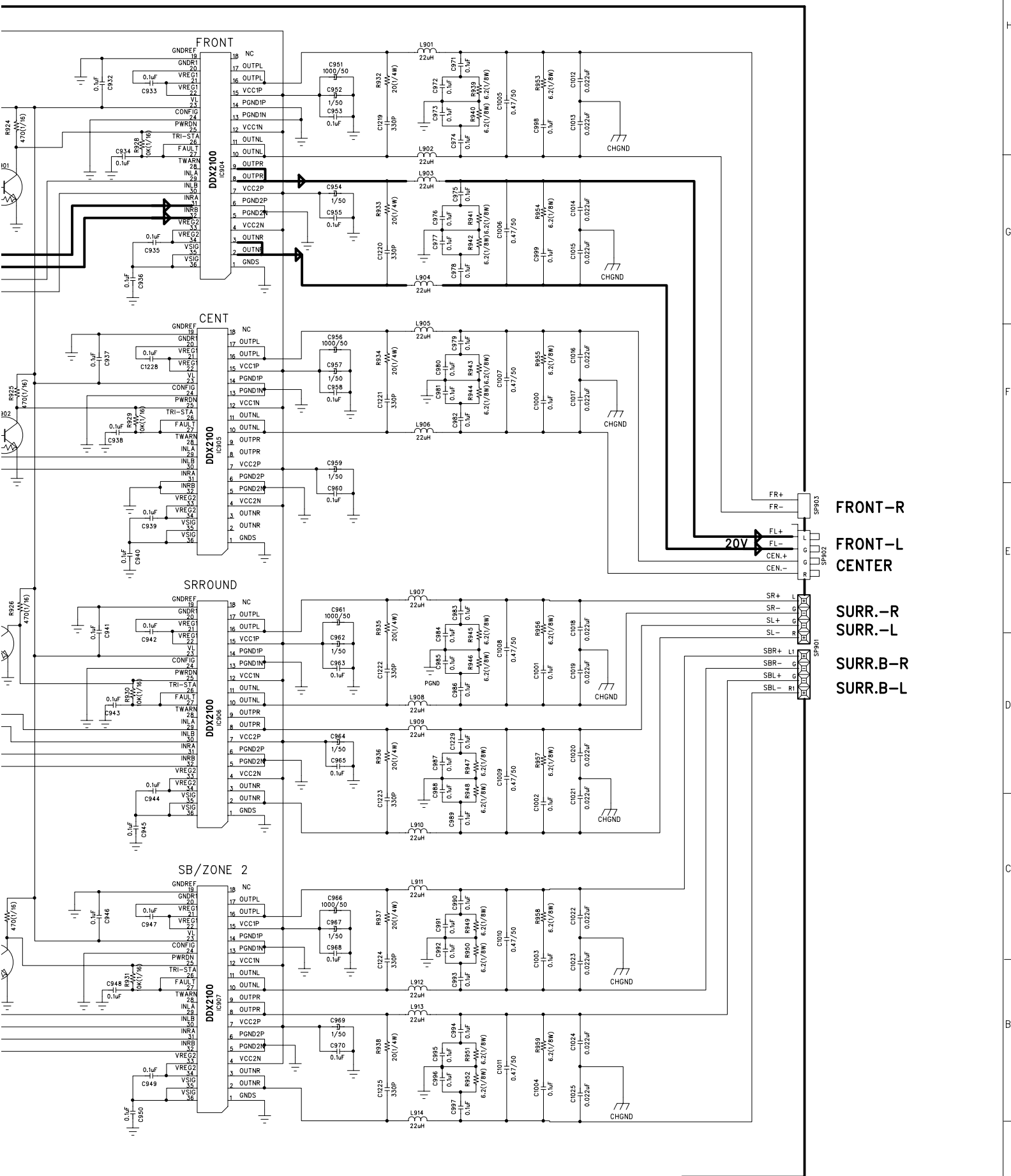

NO	DATE	POS.	CONTENTS	NO	DATE	POS.	CONTENTS

CONFIDENTIAL/CONTROL COPY				
FILENAME	CODE NO.	SHEET		
MODEL DPR1001	DESIGN JK	CHKD	CHKD	APPROVAL [Signature]
DESIGN DATE 2003.02.07	KANG			[Signature]

5. VIDEO

12	11	10	9	8	7	6	5	4	3	2	1

DPR-1001 SCHEMATIC DIAGRAM (VIDEO CIRCUIT PARTS)

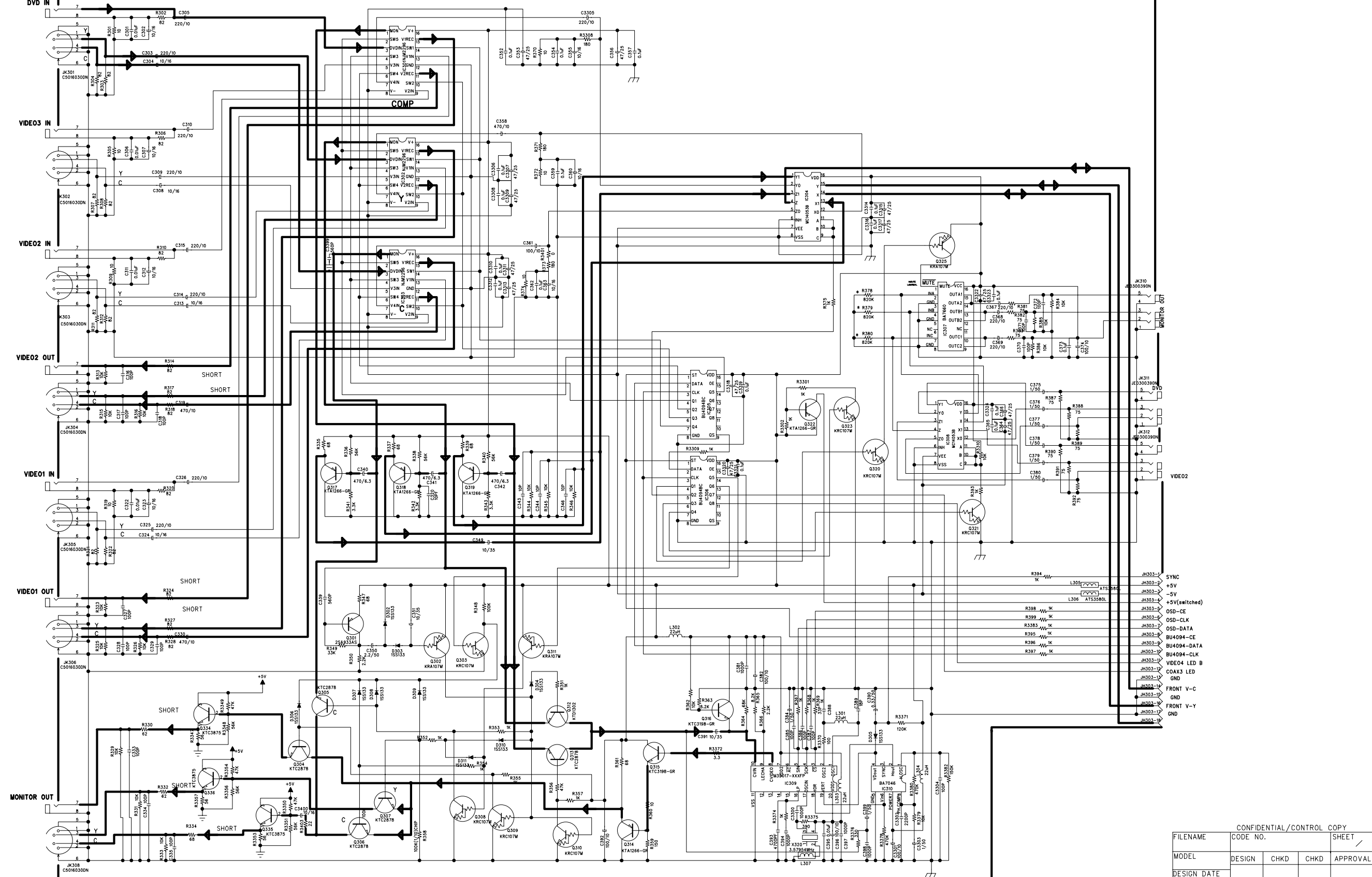

CONFIDENTIAL/CONTROL COPY				
FILENAME	CODE NO.	SHEET		
MODEL	DESIGN	CHKD	CHKD	APPROVAL
DESIGN DATE				

# DPR1001

harman/kardon

# DPR-1001 SCHEMATIC DIAGR

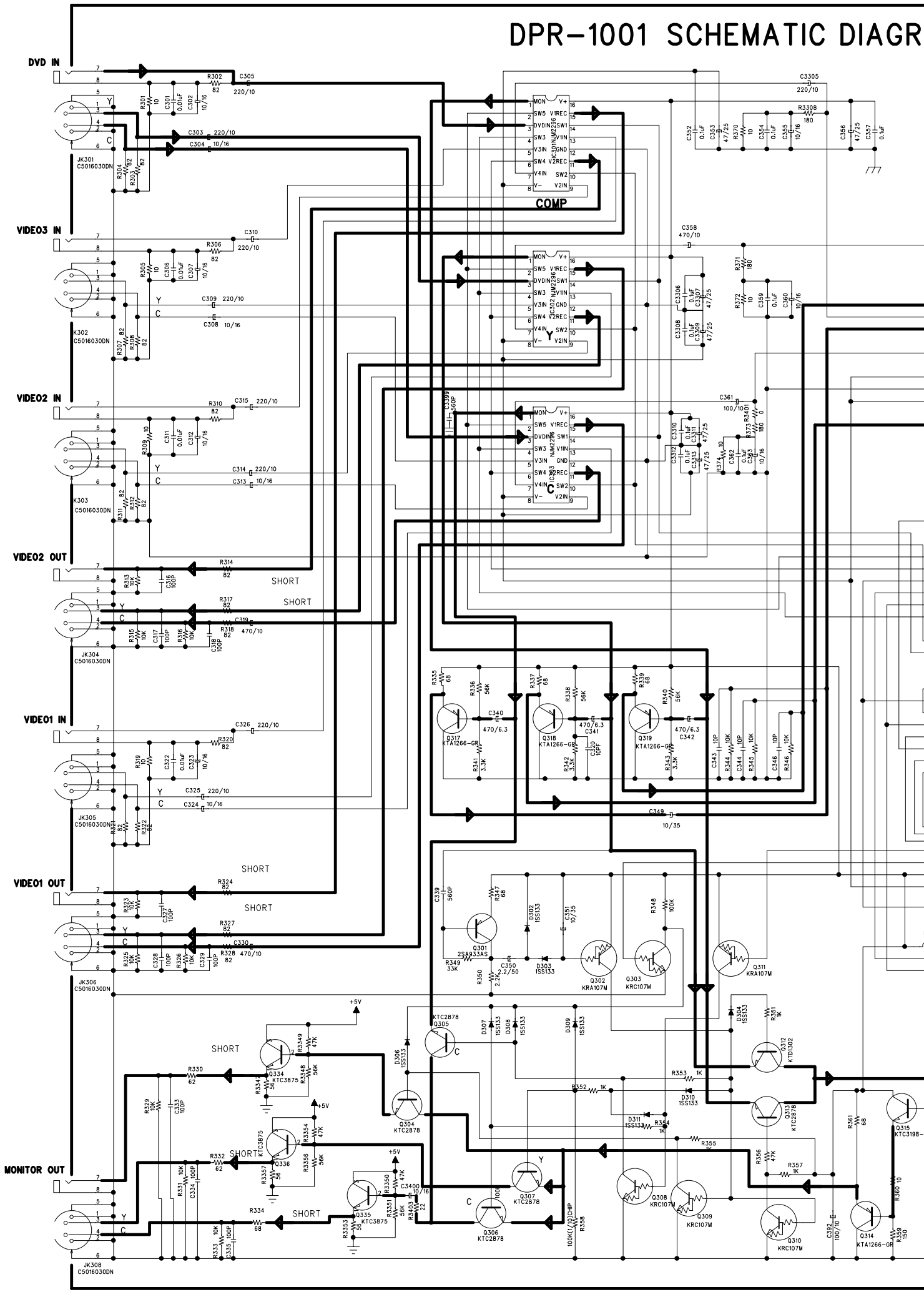



6. Digital Input

12 11 10 9 8 7 6 5 4 3 2 1

NO	DATE	POS.	CONTENTS	NO	DATE	POS.	CONTENTS

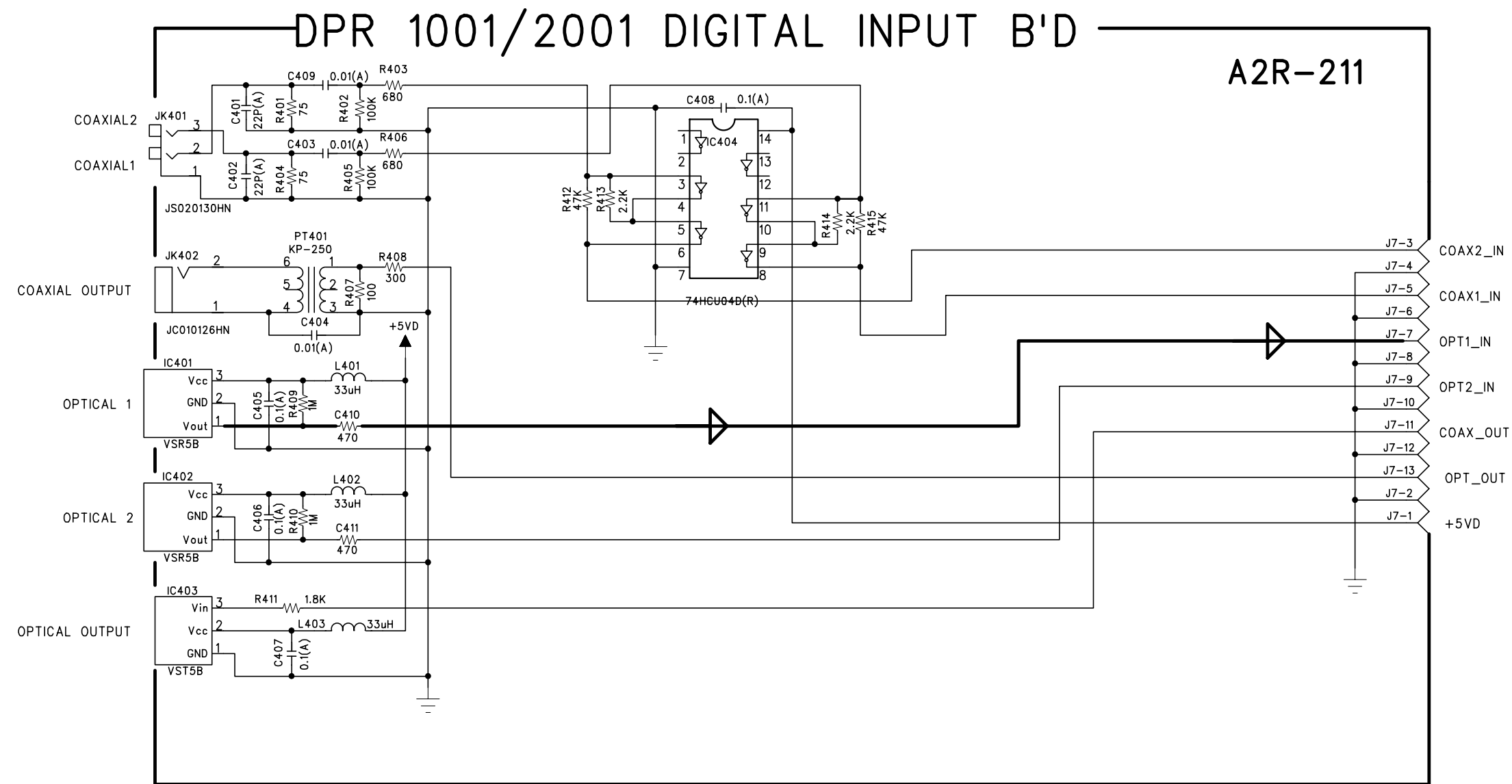

CONFIDENTIAL/CONTROL COPY

FILENAME	CODE NO.			SHEET
MODEL	DESIGN	CHKD	CHKD	APPROVAL
DESIGN DATE				





7. 6/8CH Direct Input&Output

12	11	10	9	8	7	6	5	4	3	2	1					
									NO	DATE	POS.	CONTENTS	NO	DATE	POS.	CONTENTS

DPR1001 MR/REC/HP/AC OUTLET SCHEMATIC

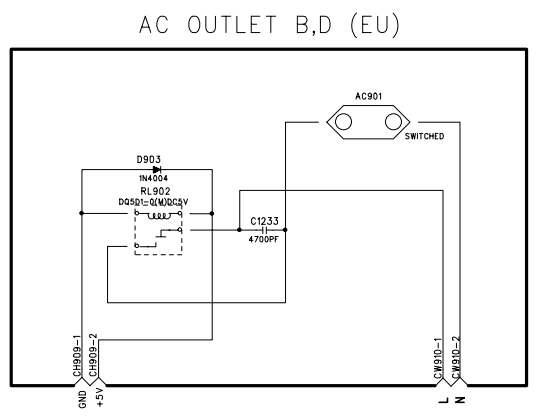
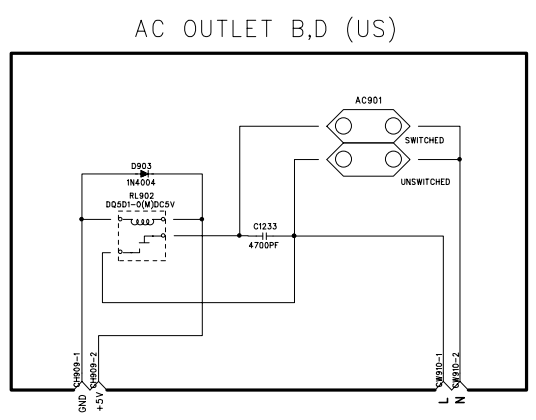
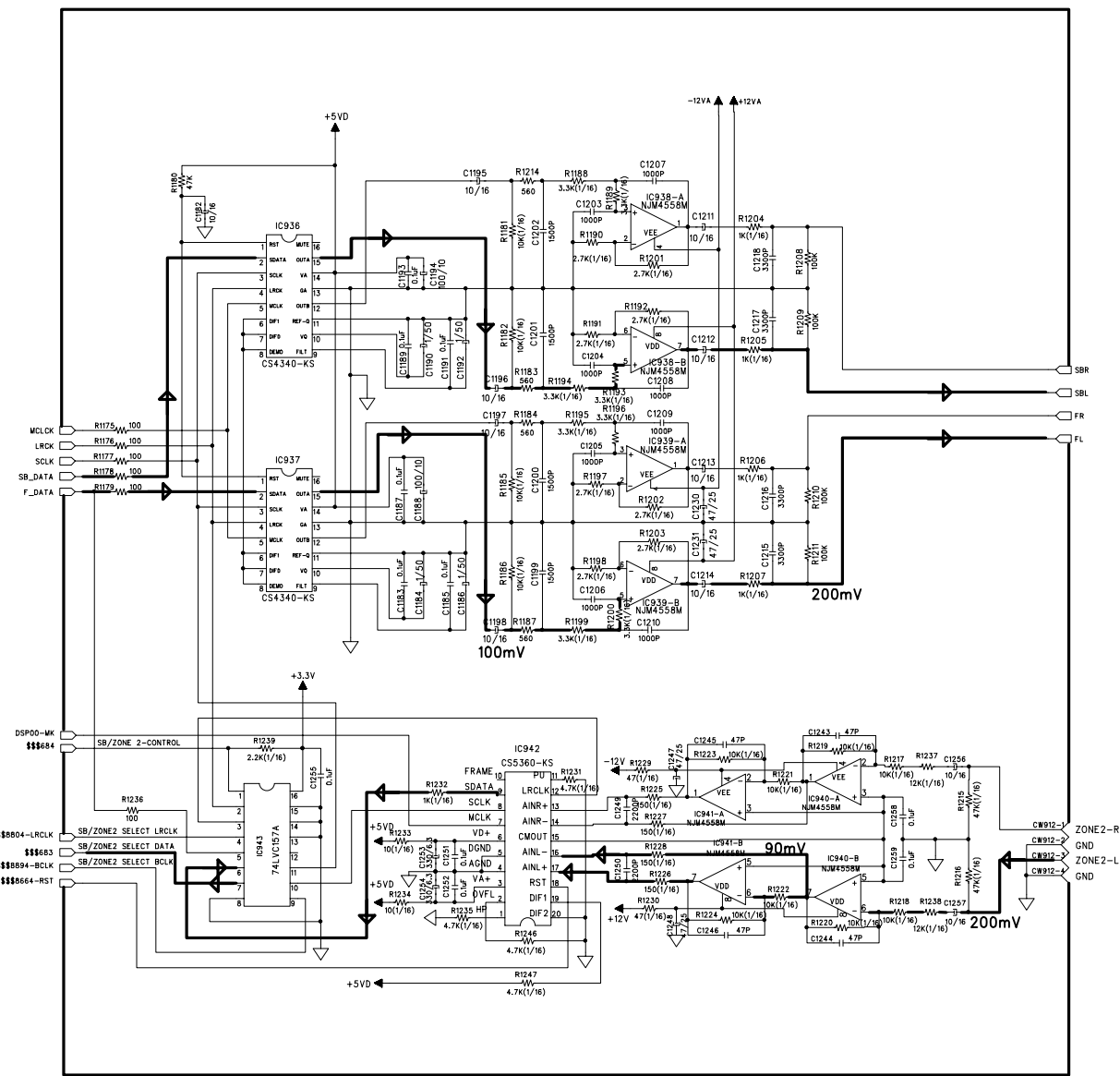

CONFIDENTIAL/CONTROL COPY					
FILENAME	CODE NO.	SHEET			
MODEL	DESIGN	CHKD	CHKD	APPROVAL	
DPR1001	JK			[Signature]	
DESIGN DATE	KANG				
2003.02.07					



NO	DATE	POS.	CONTENTS	NO	DATE	POS.	CONTENTS

# AC OUTLET SCHEMATIC

DPR1001

harman/kardon

### AC OUTLET B,D (US)

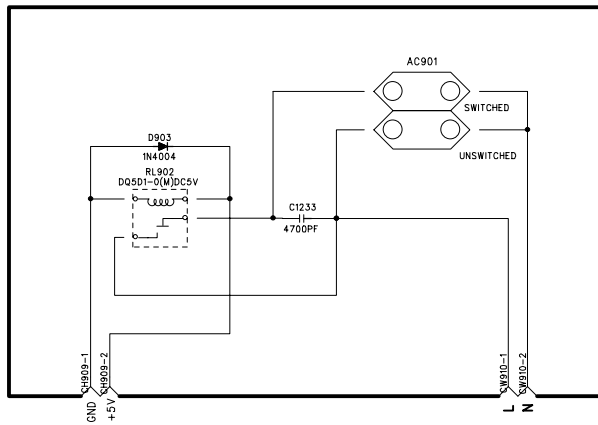

### AC OUTLET B,D (EU)

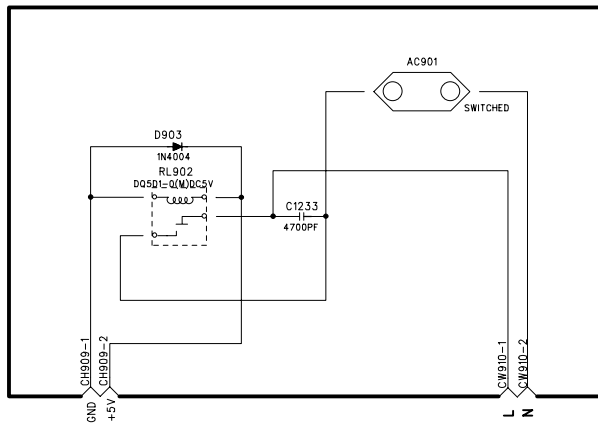

CONFIDENTIAL/CONTROL COPY				
FILENAME	CODE NO.			SHEET
MODEL	DESIGN	CHKD	CHKD	APPROVAL
DPR1001	JK			☑
DESIGN DATE				
2003.02.07	KANG			

# WIRING DIAGRAM DPR1001

harman/kardon

## DPR 1001 WIRING DIAGRAM

NO	DATE	POS.	CONTENTS	NO	DATE	POS.	CONTENTS

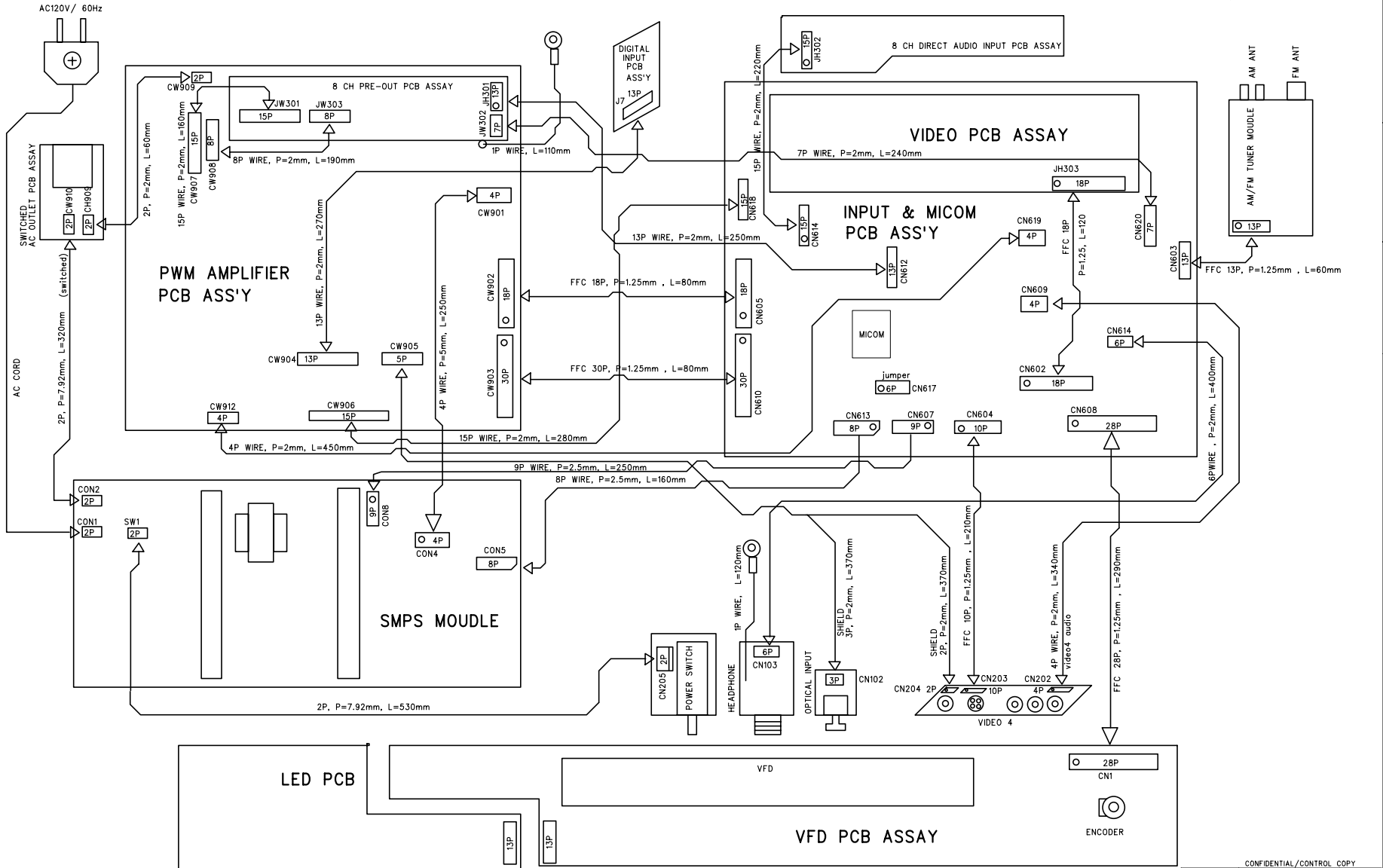

BD TO BD CONNECTER

CONFIDENTIAL/CONTROL COPY				
FILENAME	CODE NO.	SHEET	/	
MODEL	DESIGN	CHKD	CHKD	APPROVAL
DESIGN DATE				

# PACKING MATERIAL

# DPR-1001

